

# SERVICE MANUAL

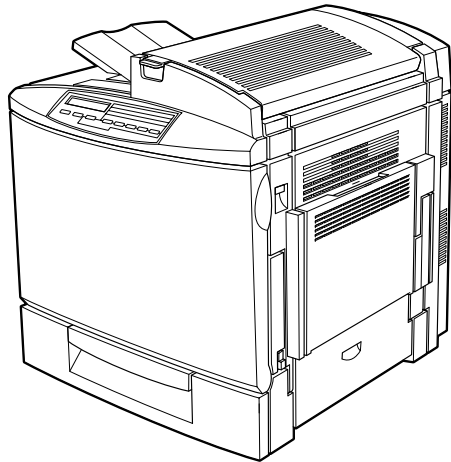

A4 Color Laser Printer

**EPSON AcuLaser Color 2000**



**EPSON®**

SEPG00004

## **Notice:**

- All rights reserved. No part of this manual may be reproduced, stored in a retrieval system, or transmitted in any form or by any means, electronic, mechanical, photocopying, recording, or otherwise, without the prior written permission of SEIKO EPSON CORPORATION.
- The contents of this manual are subject to change without notice.
- All effort have been made to ensure the accuracy of the contents of this manual. However, should any errors be detected, SEIKO EPSON would greatly appreciate being informed of them.
- The above notwithstanding SEIKO EPSON CORPORATION can assume no responsibility for any errors in this manual or the consequences thereof.

EPSON is a registered trademark of SEIKO EPSON CORPORATION.

General Notice: Other product names used herein are for identification purpose only and may be trademarks or registered trademarks of their respective owners. EPSON disclaims any and all rights in those marks.

Copyright © 2000 SEIKO EPSON CORPORATION. Printed in Japan.

# PRECAUTIONS

Precautionary notations throughout the text are categorized relative to 1) Personal injury and 2) damage to equipment.

**DANGER** Signals a precaution which, if ignored, could result in serious or fatal personal injury. Great caution should be exercised in performing procedures preceded by DANGER Headings.

**WARNING** Signals a precaution which, if ignored, could result in damage to equipment.

The precautionary measures itemized below should always be observed when performing repair/maintenance procedures.

## **DANGER**

1. ALWAYS DISCONNECT THE PRODUCT FROM THE POWER SOURCE AND PERIPHERAL DEVICES PERFORMING ANY MAINTENANCE OR REPAIR PROCEDURES.
2. NO WORK SHOULD BE PERFORMED ON THE UNIT BY PERSONS UNFAMILIAR WITH BASIC SAFETY MEASURES AS DICTATED FOR ALL ELECTRONICS TECHNICIANS IN THEIR LINE OF WORK.
3. WHEN PERFORMING TESTING AS DICTATED WITHIN THIS MANUAL, DO NOT CONNECT THE UNIT TO A POWER SOURCE UNTIL INSTRUCTED TO DO SO. WHEN THE POWER SUPPLY CABLE MUST BE CONNECTED, USE EXTREME CAUTION IN WORKING ON POWER SUPPLY AND OTHER ELECTRONIC COMPONENTS.

## **WARNING**

1. REPAIRS ON EPSON PRODUCT SHOULD BE PERFORMED ONLY BY AN EPSON CERTIFIED REPAIR TECHNICIAN.
2. MAKE CERTAIN THAT THE SOURCE VOLTAGES IS THE SAME AS THE RATED VOLTAGE, LISTED ON THE SERIAL NUMBER/RATING PLATE. IF THE EPSON PRODUCT HAS A PRIMARY AC RATING DIFFERENT FROM AVAILABLE POWER SOURCE, DO NOT CONNECT IT TO THE POWER SOURCE.
3. ALWAYS VERIFY THAT THE EPSON PRODUCT HAS BEEN DISCONNECTED FROM THE POWER SOURCE BEFORE REMOVING OR REPLACING PRINTED CIRCUIT BOARDS AND/OR INDIVIDUAL CHIPS.
4. IN ORDER TO PROTECT SENSITIVE MICROPROCESSORS AND CIRCUITRY, USE STATIC DISCHARGE EQUIPMENT, SUCH AS ANTI-STATIC WRIST STRAPS, WHEN ACCESSING INTERNAL COMPONENTS.
5. REPLACE MALFUNCTIONING COMPONENTS ONLY WITH THOSE COMPONENTS BY THE MANUFACTURE; INTRODUCTION OF SECOND-SOURCE ICs OR OTHER NON-APPROVED COMPONENTS MAY DAMAGE THE PRODUCT AND VOID ANY APPLICABLE EPSON WARRANTY.

# Safety Information

To prevent accidents during a maintenance procedure, strictly observe the Warnings and Cautions. Do not do anything that is dangerous or not within the scope of this document.

Do not do anything that is dangerous even if not specifically described in this manual. In addition to the descriptions below and those given in this manual, there are many situations and circumstances that are dangerous. Be aware of these when you are working with the printer.

## Power Supply and Other Electrical Devices

Before starting any service procedure, switch off the printer power and unplug the power cord from the wall outlet. If you must service the printer when the power is applied, be aware of the potential for electrical shock and do all tasks by following the procedures in this manual.



**Do not touch any live part unless you are instructed to do so by a service procedure.**

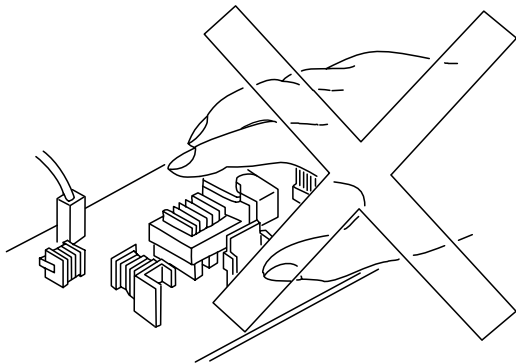

## Mechanical Components

If you service gear or roller, manually rotate a drive assembly. Never hand-rotate or stop the drive assembly while the main motor is rotating.

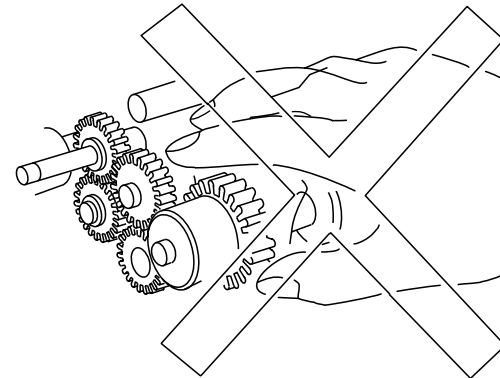

## *Laser Beam*



**The laser beam used for exposing process during printing is a very powerful, straight, narrow beam of light that produces extreme heat at its focal point. The laser beam in this printer is invisible. Although you cannot see the beam, it can still cause severe damage. Direct eye exposure to the laser beam may cause eye injury or blindness. Never place a mirror or a reflective tool or object in the laser beam path.**

To avoid permanent eye damage, follow these directions;

- Before starting any service procedure, switch off the printer power and unplug the power cord from the wall outlet.
- Do not disassemble the ROS Assembly or any laser component that displays Laser Warning Sticker.
- Use caution when you are working around the ROS Assembly or when you are performing laser related repair procedures.
- Do not disassemble the printer in such a way that the laser beam can exit the printer engine during a print cycle.

## *Safety Component*

Make sure fuses, interlock switches, covers, and panels are all functioning properly after you have reinstalled or replaced them.

### *Warning/Caution Label*

WARNING and CAUTION labels are stuck on dangerous parts in the printer to make you aware of the potential dangers that are present when you are working with those parts.

# PREFACE

This manual describes basic functions, theory of electrical and mechanical operations, maintenance and repair procedures of EPSON AcuLaser Color 2000. The instructions and procedures included herein are intended for the experienced repair technicians, and attention should be given to the precautions on the preceding page. The chapters are organized as follows:

## **CHAPTER 1. PRODUCT DESCRIPTIONS**

*Provides a general overview and specifications of the product.*

## **CHAPTER 2. OPERATING PRINCIPLES**

*Describes the theory of electrical and mechanical operations of the product.*

## **CHAPTER 3. TROUBLESHOOTING**

*Provides the step-by-step procedures for troubleshooting.*

## **CHAPTER 4. DISASSEMBLY AND ASSEMBLY**

*Describes the step-by-step procedures for disassembling and assembling the product.*

## **CHAPTER 5. ADJUSTMENTS**

*No adjustment is required for this product..*

## **CHAPTER 6. MAINTENANCE**

*Provides preventive maintenance procedures for servicing the product.*

## **APPENDIX**

*Provides the following additional information for reference:*

- MCU Internal Connection Diagram*
- Component Layout*
- Exploded Diagram*
- Circuit Diagram*

# Revision Status

Revision	Issued Date	Description
A	June 8, 2000	First Release
B	July 26, 2000	Chap. 3:On page 97, Figure 3-1 "Print Pattern" has been changed. Chap. 4:On page 126, 4.2.3.6 "Rear Controller Cover Removal" has been changed. On page 129, 4.2.4 "C314MAIN Board" has been changed.
C	Septembre 19, 2000	1.4.6 Engine Program Update is deleted. 4.3 MCU Firmware Update is deleted. This function is not supported for mass-production.

# Contents

## *Chapter 1 Product Descriptions*

---

<b>1.1 Overview</b> .....	12
<b>1.2 Controller Unit Specifications</b> .....	15
1.2.1 Controller Basic Specifications .....	15
1.2.2 Engine Specifications .....	15
1.2.3 Process Specification .....	20
1.2.4 Paper Specification .....	21
1.2.5 Sensors .....	23
1.2.6 Reliability, Durability, Serviceability .....	26
1.2.7 Operating Conditions (Including Consumables) .....	27
1.2.8 Storage and Transport Environments (Including Consumables) .....	28
1.2.9 Electrical Characteristics .....	29
1.2.10 Applicable Standards and Regulations .....	30
1.2.11 Consumable Specifications .....	31
1.2.11.1 Developer cartridges .....	31
1.2.11.2 Photoconductor kit .....	32
1.2.11.3 Waste Toner Collector .....	32
1.2.11.4 Fuser Kit .....	33
1.2.11.5 Transfer Belt Unit .....	33
<b>1.3 Interface Specifications</b> .....	34
1.3.1 Parallel Interface Specifications .....	34
1.3.2 Ethernet Interface Specifications .....	35
1.3.3 Optional Interface Specifications .....	35
<b>1.4 Control Panel</b> .....	37
1.4.1 Exterior View and Names .....	37
1.4.1.1 LED Description .....	37
1.4.2 Button Functions .....	38
1.4.3 One Touch Setting Modes .....	39
1.4.4 Panel Setting Item List .....	40
1.4.5 Explanation of Each Setting Menu and Items .....	47
1.4.5.1 Printing Menu .....	47
1.4.5.2 Tray Menu .....	48
1.4.5.3 Config Menu .....	48

1.4.5.4 Setup Menu .....	50
1.4.5.5 Maintenance Menu .....	51
1.4.6 Service Operations .....	52
<b>1.5 About RAM Expansion</b> .....	53
<b>1.6 Engine Restrictions</b> .....	54
1.6.1 Restriction on Printing Speed .....	54
1.6.1.1 Toner Duty Restrictions .....	54
<b>1.7 Handling Precautions</b> .....	55
1.7.1 Caution when there is a Power Failure .....	55
1.7.2 Caution Regarding High Temperature Parts .....	55

## *Chapter 2 Operating Principles*

---

<b>2.1 Mechanism Overview</b> .....	58
2.1.1 Gear Roller Arrangement .....	59
<b>2.2 Printing Process</b> .....	67
2.2.1 Paper Feed Mechanism .....	68
2.2.1.1 Tray 1 .....	68
2.2.1.2 Tray 2 (Cassette 1) .....	69
2.2.1.3 Tray 3 (Cassette 2) .....	69
2.2.1.4 Timing Roller .....	70
2.2.2 Charging Process .....	70
2.2.3 Exposure Process .....	72
2.2.4 Development Process .....	73
2.2.4.1 Toner Cartridge Rack .....	73
2.2.4.2 Toner Cartridge .....	75
2.2.4.3 Names of Unit Contacting Terminals .....	78
2.2.5 Transfer Process .....	79
2.2.5.1 Mid-Transfer Belt Unit .....	79
2.2.5.2 Mid-Transfer .....	79
2.2.5.3 Paper Transfer .....	80
2.2.6 Waste Toner Bottle .....	83
2.2.7 Suction Process .....	84



2.2.8 Fusing Process .....	84
2.2.8.1 Fusing Unit .....	84
2.2.8.2 Fusing Temperature Control .....	86
2.2.8.3 Fusing Oil Roll .....	89
2.2.9 Paper Eject Process .....	89
2.2.9.1 Duplex Unit (option) .....	90
<b>2.3 Controller Board (C314MAIN) Operating Principles .....</b>	<b>92</b>
2.3.1 Specification .....	92

## Chapter 3 Troubleshooting

<b>3.1 Troubleshooting Method .....</b>	<b>94</b>
3.1.1 Troubleshooting Procedure .....	94
3.1.2 Power is not Applied .....	96
3.1.3 Self Check Function .....	96
<b>3.2 Printer Message .....</b>	<b>98</b>
3.2.0.1 Messages .....	98
3.2.1 Printer Message Details of Status Messages and Remedies ..	101
3.2.2 Details of Error Messages and Remedies .....	101
3.2.3 Details of Warning Messages and Remedies .....	104
3.2.4 .....	Service Call Error Messages 106
3.2.4.1 Engine Related Service Call Error Messages .....	106
3.2.4.2 Engine Related Service Call Error Troubleshooting .....	107
3.2.4.3 Controller Related Service Call Error Messages .....	114
<b>3.3 Image Quality Troubleshooting .....</b>	<b>116</b>

## Chapter 4 Disassembly and Assembly

<b>4.1 Overview .....</b>	<b>120</b>
4.1.1 Cautions .....	120
4.1.2 Service Tools .....	120
4.1.3 Screws, Small Parts .....	121
4.1.4 Fuses .....	121
<b>4.2 Disassembling Procedure .....</b>	<b>122</b>
4.2.1 Overview .....	122
4.2.2 Before Disassembling the Printer .....	123
4.2.3 Outer Cover Removal .....	123
4.2.3.1 Front Cover Removal .....	123

4.2.3.2 Operation Panel Removal .....	124
4.2.3.3 Front Inner Cover Removal .....	124
4.2.3.4 Top Cover Removal .....	125
4.2.3.5 Left Cover Removal .....	125
4.2.3.6 Rear Controller Cover Removal .....	126
4.2.3.7 Rear Cover Removal .....	127
4.2.3.8 Rear Right Cover Removal .....	127
4.2.3.9 Left Rear Cover Removal .....	128
4.2.3.10 Rear Left Cover Removal .....	128
4.2.4 C314MAIN Board .....	129
4.2.4.1 C314MAIN Board Removal .....	129
4.2.4.2 Controller Box Removal .....	131
4.2.5 MCU (PWB-A Board) Removal .....	131
4.2.6 PU1 (Power Supply Board) Removal .....	132
4.2.7 High Voltage Board (HV1, HV2) Removal .....	133
4.2.7.1 HV1 (High Voltage Board) Removal .....	133
4.2.7.2 HV2 (High Voltage Board) Removal .....	133
4.2.8 Fusing Motor Removal .....	134
4.2.9 Transfer Motor Removal .....	135
4.2.9.1 PU1 Support Plate Removal .....	135
4.2.9.2 Transfer Motor Removal .....	135
4.2.10 Fusing Pressure Motor Removal .....	136
4.2.11 Fan Motor Removal .....	136
4.2.11.1 Power Supply Fan Motor Removal .....	136
4.2.11.2 Fusing Fan Motor Removal .....	137
4.2.11.3 Transfer Belt Fan Motor Removal .....	137
4.2.11.4 Cooling Fan Motor Removal .....	138
4.2.12 Laser Safety Switch (CDRH-SW) Removal .....	138
4.2.13 Waste Toner Full Sensor Removal .....	139
4.2.14 MP Tray Paper Load .....	140
4.2.14.1 Paper Load Cover Removal .....	140
4.2.14.2 MP Tray Paper Load Solenoid Removal .....	140
4.2.15 MP Tray Paper Load Unit .....	141
4.2.15.1 Front Bearing for the MP Tray Paper Load Unit Removal	141
4.2.15.2 MP Tray Paper Load Unit Removal .....	141
4.2.16 Paper Cassette .....	142
4.2.16.1 Paper Size Switch Removal .....	142
4.2.16.2 Paper Near Empty Sensor Removal .....	142
4.2.16.3 Cassette Paper Load Solenoid Removal .....	142
4.2.17 Transfer Mechanism .....	143

4.2.17.1 Timing Roller Solenoid Removal .....	143
4.2.17.2 Middle Roller Solenoid Removal .....	143
4.2.17.3 Lower Paper Load Guide Removal .....	144
4.2.17.4 Timing Sensor Removal .....	144
4.2.18 OHP Sensor Removal .....	144
4.2.19 Developer Mechanism .....	145
4.2.19.1 Toner Empty Sensor Removal .....	145
4.2.19.2 Front Side Rack Bearing Removal .....	145
4.2.19.3 Rack Lock Lever Removal .....	146
4.2.19.4 Rack Black Position Sensor Removal .....	146
4.2.19.5 Developer Motor Assy. Removal .....	147
4.2.19.6 Rear Rack Bearing Removal .....	147
4.2.19.7 Rack Removal .....	148
4.2.20 PH (Print Head) Mechanism .....	149
4.2.20.1 PH Connector Removal .....	149
4.2.20.2 PH Cover Removal .....	149
4.2.20.3 PH Removal .....	150
4.2.21 Transfer Mechanism .....	150
4.2.21.1 Transfer Roller Pressure Solenoid Removal .....	150
4.2.21.2 Transfer Roller Pressure Sensor Removal .....	151
4.2.21.3 Suction Fan Motor Removal .....	152
4.2.21.4 Middle Paper Sensor Removal .....	152
4.2.22 Belt Cleaner Mechanism .....	153
4.2.22.1 Left Upper Support Plate Removal .....	153
4.2.22.2 Left Frame Plate Removal .....	153
4.2.22.3 Belt Cleaner Estrangement Position Sensor Removal ...	154
4.2.22.4 PWB-I (Belt Cleaner Control Board) Removal .....	154
4.2.23 Fusing Mechanism .....	155
4.2.23.1 Pressure Roller Estrangement Sensor Removal .....	155
4.2.24 Paper Eject Mechanism .....	155
4.2.24.1 Paper Eject Sensor Removal .....	155
4.2.25 Rack Motor Assy. ....	156
4.2.25.1 Power Switch Removal .....	156
4.2.25.2 Rack Motor Assy. Removal .....	156
4.2.26 Duplex Unit .....	157
4.2.26.1 Duplex Paper Feed Sensor Removal .....	157
4.2.26.2 Duplex Unit Board Cover Removal .....	157
4.2.26.3 Duplex Unit Board (PWB-AD) Removal .....	158
4.2.26.4 Motor Cover Removal .....	158
4.2.26.5 Motor Plate Removal .....	159

4.2.26.6 Reverse Motor Removal .....	159
4.2.26.7 Duplex Paper Load Motor Removal .....	159

<b>4.3 Program ROM Update .....</b>	<b>160</b>
4.3.1 Program ROM Update .....	160
4.3.1.1 Error Indication and Remedies .....	160
4.3.2 DIMM Module Copy .....	161

## *Chapter 5 Adjustment*

---

<b>5.1 Adjustment .....</b>	<b>163</b>
-----------------------------	------------

## *Chapter 6 Maintenance*

---

<b>6.1 Maintenance .....</b>	<b>165</b>
6.1.1 Replacement Parts .....	165
6.1.2 Cleaning .....	165

## *Chapter 7 Appendix*

---

<b>7.1 Overview .....</b>	<b>167</b>
7.1.1 MCU Internal Connection Diagram .....	167
<b>7.2 Component Layout .....</b>	<b>169</b>
<b>7.3 Exploded Diagram .....</b>	<b>172</b>
<b>7.4 Parts List .....</b>	<b>173</b>
<b>7.5 Circuit Diagram .....</b>	<b>181</b>

**CHAPTER**

**1**

**PRODUCT DESCRIPTIONS**

## 1.1 Overview

---

This printer is a non-impact color page printer driven by a laser and electrophotographic technologies. It has a resolution of 600/300 dpi and print speed is 5 ppm (A4/LT color)/20 ppm (A4/LT B/W). It is also equipped with AcuLaser Color Halftoning as its full color technology.

### Engine Features

---

1. High speed print engine at a print speed of 5 PPM for color, and 20 PPM for B/W (when printing A4/LT). The engine is capable of printing true 600 dpi high resolution in full color.
2. Duplex printing supported (A4/LT). Cannot print duplex for thick paper, transparency and labels.
3. Higher quality printing is possible with high quality plain paper.
4. Capable of printing thick paper and OHP (exclusive OHP sheets is recommended).
5. Features easy maintenance as a color laser printer. The user can replace all consumables.
  - Toner cartridges (C, M, Y, K)
  - Photoconductor Kit
  - Photoconductor unit, Waste Toner Collector and Print Head Filter included.
  - Fuser Oil Roll
  - Fuser Kit
  - Fuser unit, 2nd Transfer Roll included
  - Transfer Belt Unit
  - Waste Toner Collector (Can be applied separately.)
6. Standard paper feed includes 2 bins; MP tray (up to 150 sheets) and Lower cassette (up to 500 sheets, A4/LT). Including the optional single Lower cassette (up to 500 sheets, A4/LT),

paper feeding of up to 1150 sheets from 3 bins is possible. MP Tray can hold up to 50 sheets of thick paper, transparency or label sheet.

7. Standard paper output can output 500 sheets Face-down.

### Controller Features

---

1. High Speed Controller employing new CPU
  - A new 64-bit RISC CPU R5000 - 266 MHz
  - 64-bit high speed memory SDRAM DIMM
  - Standard RAM is 32 MB (TBD). By installing additional RAM, it is possible to expand the memory to 288 MB (32MB + 256MB). (Furthermore, it is expandable up to 512 MB if remove the standard 32MB RAM then install 256 MB RAM to the slot.)
2. Equipped with Enhanced ASIC (VIP1a). Color management technology has been incorporated into the hardware to achieve high speed processing.
  - AcuLaser Color Halftoning drawing area
  - CCNV (Color conversion )
  - CCMP (Color compression/expansion)
  - CRIT (Character smoothing).
3. Equipped with 2 standard interfaces.
  - IEEE 1284 compatible and ECP compatible parallel Interface
  - Ethernet interface (100Base-TX/10Base-T)
4. By expanding memory with RAM DIMMs, the following functions can be enhanced and speeded up.
  - CPGI drawing area
  - Print Speed
  - Resolution
5. ROM update function (RCC compatible) when a Flash DIMM is installed.

6. Euro symbol supported
7. HDD (optional) can be installed

---

## Software Features

---

1. Color technologies
  - ESC/Page-Color supports B/W printing. (Speeded up in automatic discrimination of color and B/W.) (TBD)
  - Smooth expanding of color images by ESC/Page-Color. (TBD)
  - Automatic color adjustment. (at powering on / when cover is closed (excludes paper jam) / at a time after 24hours passed or 100 pages printed since color adjustment have been done previously and returning from standby )
2. Job management (TBD)  
Printing status confirmation and job cancel are enabled for job printed from built-in network by EPSON Direct Print and internal network.
3. Through bi-directional EPL and MIB, the printer status and printer environment are monitored.
4. Remote panel function through a Web browser (compatible with Java JDK1.1).
5. When a HDD (option) is installed, electronic sorting, I/F reception buffer expansion (only for Ethernet I/F) and font registration when PostScript3 mode can be equipped.
6. Additional built-in fonts  
Euro Symbol supported. NLSP Bitmap3 Plus is installed in the main unit font ROM. PCLit771 is added.
7. Installed emulations
  - Standard: ESC/Page-Color, PCL5e(B/W), GL-Like(B/W), FX(B/W), ESCP2(B/W), I239X(B/W), ESC/Page(B/W)
  - Options: Adobe Postscript Level3(Kent-Color)

- Other:
  - EPL, PPL mode
  - RCC mode (firmware update)
  - MCU update mode (mechanical-controller firmware update)
  - DIAG Mode (engine configuration)
- Auxiliary softwares
  - Status Sheet
  - Network Status Sheet
  - AUX Status Sheet (only when Type-B Level3 installed)
  - PS3 Status Sheet (only when PostScript3 module installed)
  - Font Sample (for each mode)
  - Hex dump
  - Support Mode
  - Maintenance Mode (Engine Status Sheet, for printer engine)

**Exterior View and Names**

1. External view

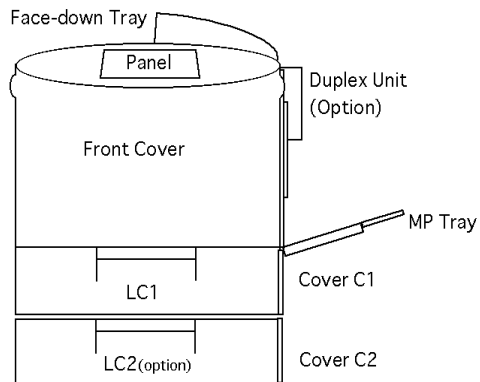

2. When open all covers except Front cover

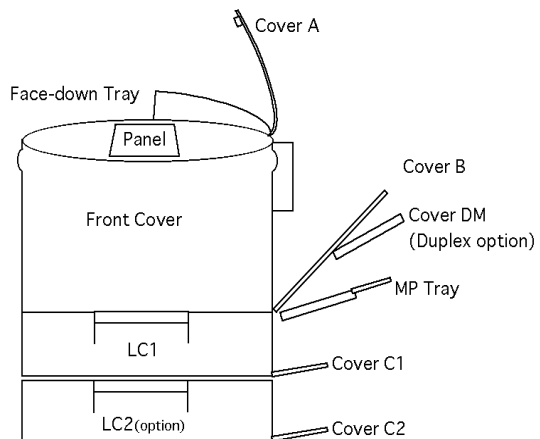

3. When open the Front cover

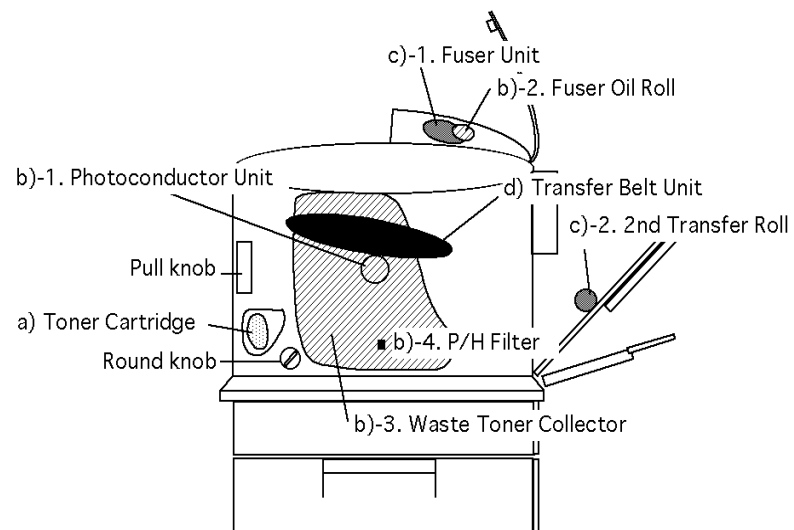

## 1.2 Controller Unit Specifications

### 1.2.1 Controller Basic Specifications

#### CPU

64bit RISC CPU R5000 (266MHz)

#### ASIC

VIP1a (AcuLaser Color Halftoning, CCNV, CCMP, CRIT, Enhanced MicroGray)

#### RAM

- SDRAM 64bit width DIMM (168pins, 3.3V)
- 2 slots (install the standard RAM to one slot and SDRAM DIMM must be installed to slot-0)
  - Standard: 32MB (TBD)
  - Optional RAM: 32MB, 64MB 128MB and 256MB (Can be expanded to up to 512MB by installing 256MB to both slots.)

#### ROM

32bit width

- Program: 4MB (Flash ROM DIMM)
- Fonts: 4MB
- Expansion ROM: 2 slots (ROM DIMM slots) (can be installed and removed only with power off)
- A, B slot: PS3, font ROM module, Overlay ROM module

#### Host Interface

- Standard
  - Parallel 1ch Bi-directional based on IEEE 1284 standard, B-type connector Compatibility, Nibble, ECP
  - Ethernet 100Base TX / 10Base-T
- Optional
  - Type B 1 slot (Level3 compatible)

#### Printer Settings

Panel settings, EJP, PJP, HTTP, SNMP and ENPC.

- Storage cell EEPROM 16Kbytes

#### Control Panel

20-digit LCD, 8-switches, 6-LEDs,

#### HDD

1 (optional) IDE type

#### Installation Method

Fixed to main unit

### 1.2.2 Engine Specifications

#### Printing Method

Electrophotographic method using scanning semiconductor laser beam and dry one- component toner.

**Resolution**

600 dpi (switching with engine)

**Print Mode**

- B/W mode: Monochrome mode. Offering maximum printing speed of this printer.
- Color mode: Color mode, printing in Y, M, C, K toners.

**Speed Mode**

- Standard mode: Paper feed at the maximum speed of this printer.
- Half-speed mode: Reduced paper feed rate to ensure fixing on thick paper (exceeding 90 g/m<sup>2</sup> 24 lb), envelopes, and transparencies.

**Printing Speed\*1**

**Table 1-1. Printing Speed**

Printing mode	Speed mode	Single-sided printing A4/LT/A5/B	Duplex printing
B/W	Standard mode	20 PPM	13 PPM
	Half-speed mode	3.8 PPM	
Color	Standard mode	5 PPM	5 PPM
	Half-speed mode	2.4 PPM	

\*1: Excluding limits on printing speed described in "Restriction on Printing Speed" on page 54.

**First Printing Time**

**Table 1-2. First Printing Time**

Printing mode	Speed mode	Single-sided printing A4/LT/A5/B			Duplex printing
		A4	LT/B	A5	A4/LT
B/W	Standard mode	16 sec.	16 sec.	16 sec.	25 sec.
	Half-speed mode	29 sec.	28 sec.	28 sec.	
Color	Standard mode	25 sec.	25 sec.	25 sec.	37 sec.
	Half-speed mode	38 sec.	38 sec.	37 sec.	

**Warm-Up Time (TBD)**

- 120 V: 150 sec. (Max.) (at 22°C, 55%RH, rated voltage)
- 220 - 240 V: 160 sec. (Max.) (at 22°C, 55%RH, rated voltage)



---

**Paper Supply**

---

**Table 1-3. Paper Supply**

Paper feed method		Capacity	Paper size	Paper thickness
Standard tray* <sup>1</sup>	Standard universal tray	150 sheets	Paper Width: 92 to 216 mm Paper Length: 210 to 297 mm	60 to 90 g/m <sup>2</sup> (recommended paper, plain paper)
		10 sheets	Envelope (TBD)* <sup>2</sup>	---
		50 sheets	92 x 148 to 216 x 297 mm transparencies/labels/thick paper	91 to 163 g/m <sup>2</sup> (thick paper, special paper)
Cassette unit* <sup>3</sup> * <sup>4</sup>	Standard cassette	500 sheets	A4/LT	60 to 90 g/m <sup>2</sup> (recommended paper, plain paper), transparencies
		50 sheets	Transparencies (TBD)	
	Optional Cassette	500 sheets	A4/LT	60 to 90 g/m <sup>2</sup> (recommended paper, plain paper), transparencies
		50 sheets	Transparencies (TBD)	

\*1: Paper size detection and near empty detection are not installed, paper out sensor installed. Paper existence is detected when one sheet of paper (post card or a paper larger than A5T) is set.

\*2: - Flap is on the short edge and is folded :

Set the envelope with flap toward the paper feed roller side.

- Flap is on the long edge and is folded :

Set the envelope in portrait direction and with flap toward right side of paper feed direction.

- Flap is on the short edge and is opened :

Set the envelope with flap opened and toward the opposite side of paper feed roller.

- Flap is opened and sticky with paste : Not supported.

\*3: Each cassette unit has independent Side guide and End guide (combined with paper size detectors) and can be adjusted by user. Maximum 2 cassette units can be installed and the maximum paper capacity is 1150 sheets.

\*4: Each cassette is equipped with paper-out sensor and near-empty sensor.

\* Near-empty is detected when paper remaining is 50 ± 30 sheets. (when using plain paper of 80g/m.)

---

**Duplex Printing (optional)**

---

- Supported size: A4, LT
- Paper type: Plain paper (60 to 90 g/m<sup>2</sup>)
- Paper size/Paper set direction/Duplex availability

**Table 1-4. Paper Size**

Paper Type		Paper Size	Paper Set Direction			Duplex Availability
			Standard tray	Standard cassette	Optional cassette	
Standard Paper	A4	210.0 x 297.0mm (8.27 x 11.69")	SEF* <sup>1</sup>	SEF	SEF	A* <sup>2</sup>
	A5	148.0 x 210.0mm (5.83 x 8.27")	SEF	---	---	UA* <sup>3</sup>
	B5	182.0 x 257.0mm (7.16 x 10.12")	SEF	---	---	UA
	ISO-B5	176.0 x 250.0mm (6.93 x 9.84")	SEF	---	---	UA
	Letter (LT)	215.9 x 279.4mm (8.5 x 11.0")	SEF	SEF	SEF	A
	Half Letter (HLT)	139.7 x 215.9mm (5.5 x 8.5")	SEF	---	---	UA
	Legal 13"	215.9 x 330.2mm (8.5 x 13.0")	SEF	---	---	UA
	Legal 14"	215.9 x 355.6mm (8.5 x 14.0")	SEF	---	---	UA
	EXE	184.2 x 266.7mm	SEF	---	---	UA
	F4	210.0 x 330mm (8.27 x 13")	SEF	---	---	UA
Special Paper (Envelopes)	COM10	104.8 x 241.3mm (4.13 x 9.5")	SEF* <sup>4</sup>	---	---	UA
	Monarch	98.4 x 190.5mm (3.88 x 7.5")	SEF* <sup>4</sup>	---	---	UA
	C5	162.0 x 229.0mm (6.38 x 9.02")	SEF* <sup>4</sup>	---	---	UA
	DL	110.0 x 220.0mm	SEF* <sup>4</sup>	---	---	UA
	C6	114.0 x 162 mm	SEF* <sup>4</sup>	---	---	UA

\*1: SEF (Short Edge Feed) = Set paper in portrait direction toward paper feed direction.

\*2: A = Available

\*3: UA = Unavailable

\*4: See "Paper Supply" on page 17 for details.

## Paper Feed Reference

Center line reference for each paper size and each paper feeder (standard tray/each cassette)

## Consumables

- Developer cartridge (black/cyan/magenta/yellow)
- Photoconductor kit (including Photoconductor unit, Fuser oil roll, Waste toner collector, Printhead filter)
- Fuser kit (including Fuser unit, Second transfer roll), Transfer belt unit, Waste toner collector (separately).

**NOTE:** These consumable can be replaced by the user.

## Output Paper Capacity

Face-down(FD) only. 500 sheets (using A4/LT, 80g/m<sup>2</sup> or 20 lb paper)

## Dimensions

- Main unit only : 463\*<sup>1</sup> (W) x 548 (D) x 511 (H) mm
- With Duplex unit installed : 496\*<sup>1</sup> (W) x 548 (D) x 511 (H) mm
- With optional cassette installed : 463\*<sup>1</sup> (W) x 548 (D) x 625 (H) mm
- With both of optional cassette and Duplex unit installed:  
496\*<sup>1</sup> (W) x 548 (D) x 625 (H)

## Weight

- Main unit only: 44.5kg (includes consumables)
- Duplex unit: 3.0kg

\*1: With standard tray and output tray closed.

## Power Supply

- 100/120V version: 100/120V±10%, 50-60Hz ±3Hz
- 200V version: 220V/240V±10%, 50-60Hz ±3Hz

## Power Consumption

**Table 1-5. Power Consumption**

Description		Specifications
Maximum rated current		1000W max. (100V / 120V)
		1100W max. (220 to 240 V)
During printing, average* <sup>1</sup>	B/W printing	700 Wh max.
	Color printing	550 Wh max.
During standby, average		250 Wh max.
During the heater-off state, average* <sup>2</sup>		45 Wh max.

\*1: Includes optional cassette unit and Duplex unit

\*2: Completely suspended. Conformed to the Energy Star program.

## Current Consumption

- 120V version: 10.0 A max. (at rated voltage)
- 220 to 240 V version: 6.0 A max. (at rated voltage)

---

**Life**

---

- Main unit : 500,000 pages\*1 or 5 years whichever comes earlier. (Including standard tray)
- Optional cassette unit :500,000sheets or 5 years whichever comes earlier.
- Duplex unit : 500,000 pages (250,000sheets) or 5 years whichever comes earlier.

---

**Noise**

---

- During operation: 55 dB(A) max. (TBD)
- During standby: 41 dB(A) max.

---

**Ozone Concentration**

---

0.1 ppm max. (based on UL standards)

---

**Particles Discharge**

---

Particles concentration 0.25 mg/m<sup>3</sup> max. (based on Blue Angel standards)

---

**Toxicity**

---

Photoconductor kit (OPC), toner, and plastic materials are all non-toxic.

---

*\*1: Life of 500,000 pages is calculated assuming a B/W : color job ratio of 1:1, and equivalent to 1,250,000images (4imagesx250,000pages + 250,000images). 500,000sheets or 1,250,000images whichever comes earlier is the life of the main unit, also.*

**1.2.3 Process Specification**

- Method: Electrophotographic method using dry one-component developing and Belt transfer
- Light source: Semiconductor Laser
- Photoconductor unit: OPC (Organic Photo Conductor) Drum
- Charging: Needle electrode charger
- Developing: Exposed area development
- Toner: Non-magnetic toner
- Primary transfer: Roller Transfer
- Fixing: Heated belt fixing method (with oil coated mechanism)
- Density adjustment: Automatic (non-user adjustable)

## 1.2.4 Paper Specification

### Paper Type

- Recommended paper: 4024 paper (20 lb) (B/W), FX J paper (TBD)
- Plain paper: Ordinary copy paper, recycled  
60g/m<sup>2</sup> to 90g/m<sup>2</sup> (16 lb to 24 lb)
- Special paper: Transparencies, Colored paper, Thick paper  
(91g/m<sup>2</sup> to 163g/m<sup>2</sup>, Envelope (TBD))

**NOTE 1:** lb: Ream weight = lb/500 sheets/17"x22" (431.8 x 558.8mm) g/  
m<sup>2</sup>: 1 g/m<sup>2</sup> = 0.2659763 lb

**NOTE 2:** Before buying large quantities of paper, verify that your printer will print properly with the paper.

**NOTE 3:** Do not use any of the paper types listed below with this printer. They may cause defective printing, paper blockages, or damage to the printer.

- Carbon paper, non-carbon paper, thermal paper, pressure-sensitive paper, acidic paper
- Paper previously printed in a thermal printer or ink jet printer.
- Extra thick or extra thin paper.
- Damp paper.
- Surface-coated paper or surface-treated color paper.
- Extra smooth or glossy paper. Extra rough paper.
- Paper with significantly different roughness on each surface.
- Paper with punched holes or perforations.
- Folded, curled, or torn paper.
- Irregularly shaped paper or paper with non-perpendicular corners.
- Sheets of labels that peel off easily.
- Paper with glue, staples, or clips attached.
- Special ink jet paper superfine paper, glossy film, etc.
- Transparencies for other color/monochrome laser printers or photocopiers.
- Sheets already printed on other color/monochrome laser printers or photocopiers.
- Sheets of paper stuck together.

### Paper Feeding

Table 1-6. Paper Feeding

Paper source	Recommended paper	Plain Paper	Special applications			
			Transparencies	Labels	Thick paper (90 to 163g/m <sup>2</sup> )	Envelopes
Standard tray	PA	A	A	A	A	A
Standard cassette	PA	A	NA	NA	NA	NA
Lower cassette unit (Option)	PA	A	NA	NA	NA	NA

PA: Paper feed and image quality assured.

P: Paper feed and image quality assured, but only for the use of ordinary types of paper.

NA: Not available

---

**Printing Area**

---

- Maximum printable area:Width 208mm/Length 289mm
- Guaranteed printing area

Maximum guaranteed printing area:Width 208mm/Length 289mm  
Entire paper area except for a 4mm margin at each edge of the paper up to the above size. (See the figure below.)

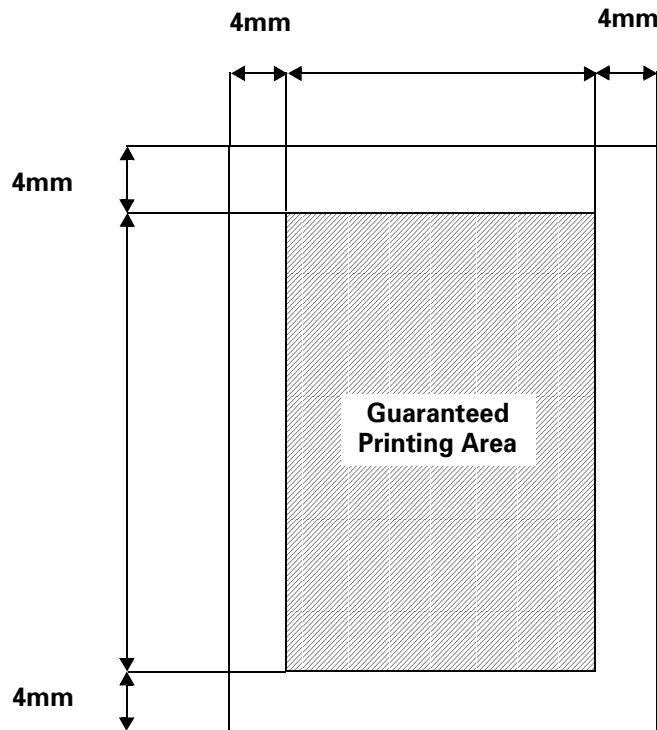

Figure 1-1. Printing Area

## 1.2.5 Sensors

### Photoconductor Unit

**Table 1-7. Sensor Specifications - Photoconductor Unit**

Detected Conditions	Detection Method	Comments
Mounted/unmounted	Electrical contact detection method	---
New product	Fuse method (Cut fuse in new product)	---
Mounted/unmounted detection at powering on	Electrical contact detection method	<ul style="list-style-type: none"> <li>• Can be mounted/unmounted while power is on</li> <li>• No damage on mechanism</li> <li>• Status is updated when the cover is closed</li> </ul>
Consumption	Calculate operating time (motor rotation time)	Added up in 30 sec. unit
Near end	The total operating time of the main motor	2640counts x 30sec. = 1320min.
End of life	The total operating time of the main motor.	3300counts x 30sec. = 1650min. Printing is forbidden in the following timing <ul style="list-style-type: none"> <li>• While printing of up to 100 images(300sec.) is performed after the End of life detection</li> <li>• After printing completed.</li> </ul>
Genuine SEC product	Un-compatible rib	---

### Fuser Oil Roll

**Table 1-8. Sensor Specifications - Fuser Oil Roll**

Detected Conditions	Detection Method	Comments
Mounted/unmounted	Actuator	---
Mounted/unmounted detection at powering on	Actuator	<ul style="list-style-type: none"> <li>• Can be mounted/unmounted while power is on</li> <li>• No damage on mechanism</li> <li>• Status is updated when the cover is closed</li> </ul>

### Waste Toner Collector

**Table 1-9. Sensor Specifications - Waste Toner Collector**

Detected Conditions	Detection Method	Comments
Mounted/unmounted	Actuator	---
Mounted/unmounted detection at powering on	Actuator	<ul style="list-style-type: none"> <li>• Can be mounted/unmounted while power is on</li> <li>• No damage on mechanism</li> <li>• Status is updated when the</li> </ul>
Waste toner collector full	Photo sensor	cover is closed

### Printhead Filter

**Table 1-10. Sensor Specifications - Printhead Filter**

Detected Conditions	Detection Method	Comments
Mounted/unmounted	Waste toner collector cannot be installed if the printhead filter is not installed.	---

## Fuser unit

Table 1-11. Sensor Specifications - Fuser Unit

Detected Conditions	Detection Method	Comments
Mounted/ unmounted	Electrical contact detection method (detected by voltage of speed detection trimmer inside the unit)	---
New product	Fuse method (Cut fuse in new product)	---
Mounted/ unmounted detection at powering on	Electrical contact detection method	<ul style="list-style-type: none"> <li>• Can be mounted/ unmounted while power is on</li> <li>• No damage on mechanism</li> <li>• Status is updated when the cover is closed</li> </ul>
Consumption	Total operating time of the fuser motor	Added up in 30 sec. unit
Near end	The total operating time of the fuser motor	28,880 counts
End of life	The total operating time of the main motor.	36,000 counts Printing is forbidden in the following timing <ul style="list-style-type: none"> <li>• While printing of up to 100 images (300sec.) is performed after the End of life detection</li> <li>• After printing completed.</li> </ul>

## Developer Cartridge

Table 1-12. Sensor Specifications - Developer Cartridge

Detected Conditions	Detection Method	Comments
Mounted/ unmounted	Electrical contact detection method (detected by voltage of speed detection trimmer inside the unit)	---
New product	Fuse method (Cut fuse in new product)	---
Mounted/ unmounted detection at powering on	Electrical contact detection method	<ul style="list-style-type: none"> <li>• Can be mounted/ unmounted while power is on</li> <li>• No damage on mechanism</li> <li>• Status is updated when the cover is closed and the rotary rotates once.</li> </ul>
Residual toner	Counts images by the mechanical controller.	---
Near end	Counts images by the mechanical controller Counts the luminescent period of the LD.	4,800 images or 3,200 counts of the LD luminescence period, whichever reaches earlier.
End of life	Counts images by the mechanical controller. Reflective photo sensor	6,000 images Detected by the counter whichever reaches 6,000 earlier. Printing is not forbidden.
Genuine SEC product	Un-compatible rib	---



**Transfer Belt Unit**

**Table 1-13. Sensor Specifications - Transfer Belt Unit**

Detected Conditions	Detection Method	Comments
Mounted/unmounted	Returns GND from AIDC sensor for the detection.	---
New product	Fuse method (Cut fuse in new product)	---
Mounted/unmounted detection at powering on	Returns GND from AIDC sensor for the detection.	<ul style="list-style-type: none"> <li>• Can be mounted/unmounted while power is on</li> <li>• No damage on mechanism</li> <li>• Status is updated when the cover is closed</li> </ul>
Consumption	Total operating time of the main motor	Added up in 30 sec. unit
Near end	The total operating time of the main motor	12,000 counts
End of life	The total operating time of the main motor.	15,000 counts Printing is forbidden in the following timing <ul style="list-style-type: none"> <li>• While printing of up to 100 images (300sec.) is performed after the End of life detection</li> <li>• After printing completed.</li> </ul>

**Standard tray/Optional Feeder/Duplex Unit**

**Table 1-14. Sensor Specifications  
Standard Tray / Optional Feeder / Duplex Unit**

Unit	Detected Conditions	Detection Method	Comments
Standard tray	Out of paper	Actuator	---
Optional feeder	Mounted/unmounted	Communication check with the main unit	It is not guaranteed to be unmounted/mounted while power is on. Detection is performed only at powering on.
Duplex unit	Mounted/unmounted	Detects the short pin.	

**Standard/Optional Cassette**

**Table 1-15. Sensor Specifications - Standard/Optional Cassette**

Detected Conditions	Detection Method	Comments
Mounted/unmounted	Returns GND from AIDC sensor for the detection.	
Paper size	Actuator (operates together with the end guide)	A4 or LT
Paper near end	Photo sensor	50 +/- 30 sheets (with 80g/m <sup>2</sup> paper)
Paper out	Actuator	

### 1.2.6 Reliability, Durability, Serviceability

#### MPBF

80,000 pages (200,000 images) min.\*1

#### MTBF

3,000 hours min.\*2

#### Paper Feeding Reliability

**Table 1-16. Paper Feeding Reliability\*1**

	Single-sided printing	Duplex printing
Paper jam rate	1/2000 sheets (max.)	1/1000 sheets (max.)
Paper misfeed	1/2000 sheets (max.)	---
Multiple sheet feed rate*2	1/500 sheets (max.)	---
Paper creasing	1/1000 sheets (max.)	1/500 sheets (max.)
Leading edge folded (for 1C or more)*3	1/1000 sheets (max.)	1/500 sheets (max.)

\*1: Using recommended paper in standard environment (15 to 25°C , 35 to 70%RH)

\*2: The values for multiple-sheet feed rate do not include effects at the boundary between original paper and replenished paper, occurring after paper is replenished.

\*3: 1C indicates 1mm corner fold.

\*1: In color mode, 4 images (YMCK) are printed per sheet. MPBF is calculated assuming a B/W: color job ratio of 1:1.  
e.g. : 200,000 = 80,000/2 + (80,000/2 x 4)

\*2: PV (page volume) per month : 8,000pages(average)  
calculated assuming the Operating time per month as 300 hours (average).

#### Printing Start Position Accuracy / Paper Skew

**Table 1-17. Printing Start Position Accuracy/Paper Skew\*1**

	Directions	Single-sided printing	Duplex printing
Print start position accuracy	Main Scanning Direction (c)	±2.0 mm	±3.2 mm
	Sub Scanning Direction (a)	±2.5mm	±2.0 mm
Paper skew	Main Scanning Direction (c-a)	±1.5 mm	±2.5 mm (TBD)
	Sub Scanning Direction (a-b)	±2.0mm	±3.5 mm (TBD)

\*1: With A4/LT

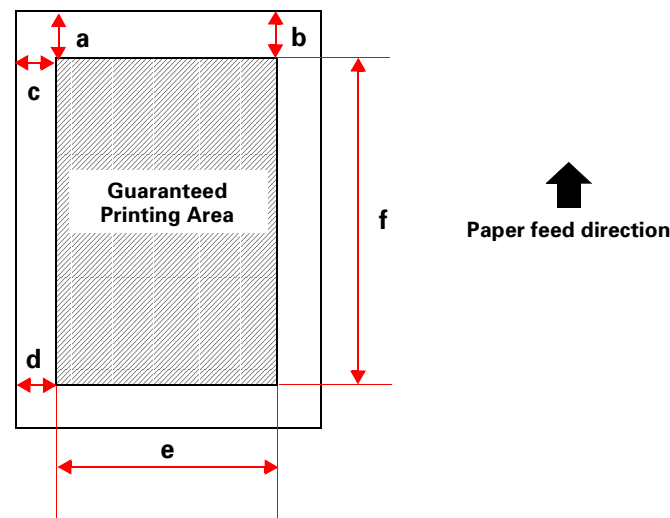

**Figure 1-2. Printing Start Position Accuracy/Paper Skew Descriptions**

---

**Serviceability**

---

MTTR 30 minutes max. (average)  
(Time for service technician to locate and repair a failure.)

---

**Output Paper Curl Height (with A4/LT)**

---

- Plain paper: ± 30mm max. (same as for duplex printing)
- Transparencies: ± 15mm max.

(For non-aligned B/W printing with 5% image occupation rate or color printing with 5% image occupation)

---

**1.2.7 Operating Conditions (Including Consumables)**

---

---

**Temperature and Humidity**

---

- Temperature: 10 to 35°C
- Humidity: 15 to 85% RH no condensation

---

**Barometric Pressure (Altitude)**

---

760 hPa min. (2,500 m max.)

---

**Levelness**

---

Max. 1° tilt (front-rear or left-right)

---

**Illumination**

---

3,000 lux max. (no direct sunlight)

---

**Printer Peripheral Space (TBD)**

---

Maintain the space shown in the diagram below around the printer to ensure normal printer operation. (Units: mm)

## 1.2.8 Storage and Transport Environments (Including Consumables)

### Temperature and Humidity

**Table 1-18. Temperature and Humidity**

Conditions	Temperature	Humidity* <sup>1</sup>	Guaranteed period
Normal conditions	0 to 35°C	30 to 85%RH	18 months from manufacture
Severe conditions	High: 35 to 40°C* <sup>2</sup> Low : -20 to 0°C	High: 85 to 95% RH Low: 10 to 30% RH	1/30 of 18months

\*1: With no condensation.

\*2: 35 to 55°C when excludes Developer cartridge and Photoconductor unit.

### Storage Barometric Pressure (Altitude)

740 to 1013 hPa\*<sup>1</sup>

### Dropping (TBD)

- For European model: No abnormalities according to JIS Z0200-1994 Level 1.
- For North America : No abnormalities according to ISTA 2A.

Also, no abnormalities by the dropping with one side supported.\*<sup>2</sup>

\*1: 613 to 1013 hPa when excludes Developer cartridge and Photoconductor unit.

\*2: Drop the short edge of the bottom from a height of 52cm, twice for both edge (total 4 times).

### Vibration

- Frequency: 5 to 100 Hz (Sweep time : 10 min.)
- Acceleration: 1.0 G (on the vibrator)
- Direction of application: 3 dimensional (along X, Y and Z axes)
- Time of application: 60 min. along each axis

### 1.2.9 Electrical Characteristics

The following items do not apply to the Optional Units.

---

#### AC Line Noise

---

- Pulse Width: 50-1000ns
- Pulse Polarity: +/-
- Repeating: Asynchronous
- Mode: Common / Normal
- Voltage: 1kv No component damage to 2kv.

---

#### Instantaneous Power Failure

---

- DIP 100% (at rated voltage - 10%) 1 cycle. No abnormality to quality in print cycle.
- Satisfies the following conditions under the evaluation conformed to "IEC61000-4-11"
  - Falls by 95%, 0.5 cycle : No print error except for slight dot error.
  - Falls by 30%, 25 cycle : No component damage
  - Falls by 95%, 250 cycle : No component damage

---

#### Static Electricity Resistance

---

- Satisfies the following conditions under the 50% Flash over method.
  - Up to ± 7 kv: No hardware error at all.
  - Up to ± 10 kv: No print error except for slight dot error.
  - Up to ± 15 kv: No component damage.
- Satisfies the following conditions under the evaluation conformed to "IEC61000-4-2"
  - Contact discharge 8kV : No device error at all
  - internal discharge 15kV : No device error at all

---

#### Inrush Current

---

1/2 cycle 50A max. (in an environment of 23°C min.)

---

#### Insulation Resistance

---

10MΩ max.

---

#### Dielectric Strength

---

No breakdown when the following voltage is applied for one minute.

**Table 1-19. Dielectric Strength**

	Across Primary and Chassis
100/120V Model	AC1000V
200V Model	AC1500V

---

#### Leak Current\*1

---

- 100V model 0.25 mA max.
- 120V model 3.5 mA max.
- 200V model 3.5 mA max.

---

\*1: Measured according to [The Guideline for Leak current of Personal computers]

## 1.2.10 Applicable Standards and Regulations

The engine specification meets the following standards and regulations. Depending on the destination, some standards and regulations apply to the product only when including controller.

### Safety Standards

- 100Vmodels
  - US : UL1950 3rd Edition
  - Canada : CSA C22.2 No.950-95 3rd
- 200Vmodels
  - Europe : IEC60950 2nd Edition + Amd 1, 2, 3, 4  
EN60950 : 1992 + Amd 1, 2, 3, 4  
EMKO-TSE (74-SEC) 207/94

### Safety Regulations (laser radiation)

- 120V FDA21CFR Chapter 1,Subchapter J, Section 1010,1040
- 200V EN60825-1 + All

**NOTE:** Laser power: 1.16 mW Max.  
Wavelength: 785 nm ± 10nm

### EMI Standards

- 120V
  - US : 47CFR Part15 SubpartB, ClassB
  - Canada : ICES-003 Issue3 ClassB (C108.8-M1983)
  - Taiwan : CNS13483 ClassB
- 200V
  - EN55022 (CISPR Publication22),ClassB

### Power Supply High Frequencies

Comply with high-frequency restriction guidelines.

### Power Consumption

Comply with International Energy Star Program standards (45W max. in Standby mode)

### Others

- Toner: No effects on the human body (conforming to OSHA, TSCA, EINECS).
- OPC: No effects on the human body (conforming to OSHA).
- Ozone generation: Conforming to UL478, Edition 5.
- Materials: Conforming to Swiss environmental-protection laws (not including CdS).

## 1.2.11 Consumable Specifications

### 1.2.11.1 Developer cartridges

#### Configuration and Life (toner consumption)

**Table 1-20. Configuration and Life**

Name	Contents	Life*1
Developer Cartridge (black)	Black toner, etc.	6,000 images
Developer Cartridge (cyan)	Cyan toner, etc.	6,000 images
Developer Cartridge (magenta)	Magenta toner, etc.	6,000 images
Developer Cartridge (yellow)	Yellow toner, etc.	6,000 images

\*1: The indicated number of images is the approximate number of printable images using A4 continuous printing at 5% image occupation rate. For color printing, this is not the number of sheets printed. The cartridge life varies according to the image occupation rate and type of printing (continuous, intermittent).

#### Dimensions/weight

- Not packaged: Dimensions = 304.5 (W) x 115 (D) x 76 (H) (mm)  
Weight = K/Y/M/C approx. 950g
- Packaged: Dimensions = 426 (W) x 170 (D) x 215 (H) (mm)  
(TBD)  
Weight = K/Y/M/C approx. 1250g

#### Storage and transport environments

(common to all Developer cartridges)

- Temperature and humidity

**Table 1-21. Temperature and Humidity - Developer Cartridge**

	Temperature	Humidity	Guaranteed period
Normal condition	0 to 35°C	30 to 85% RH*1	18months from manufacture (packaged)
Sever condition	High: 35 to 40°C*2 Low: -20 to 0°C	High: 85 to 95% RH*1 Low: 10 to 30% RH*1	1/30 of 18months

\*1: Storage up to 12 months after package is opened. (in normal environment and no condensations)

\*2: No condensation

- Storage barometric pressure (altitude):740 to 1013 hPa
- Package dropping: No abnormalities according to JIS Z0200-1987 Level 1.
- Package vibration: No abnormalities under following conditions
  - Frequency: 10 to 100 Hz (5 min.)
  - Acceleration: 9.8m/s2 (1G)
  - Direction of application: Along X, Y and Z axes
  - Time of application: 60 min. along each axis (X, Y, Z), total 180 min.

## 1.2.11.2 Photoconductor kit

## Configuration and Life

Table 1-22. Photoconductor Kit Specifications

Name	Contents	Life	Life
Photoconductor kit	<ul style="list-style-type: none"> <li>• Photoconductor unit</li> <li>• Waste toner collector</li> <li>• Fuser oil roll</li> <li>• Print head filter</li> </ul>	30,000 images*1	Continuous printing B/W : 30,000 pages Color : 7,500 pages
			Intermittent printing (1P/J) B/W : 10,000 pages Color : 5,000 pages

\*1: Standard mode : 9000pages (30,000images)  
Calculated assuming B/W = 4,500pages (3P/J : 7,500images), Color = 4,500pages (2P/J : 22,500images)  
The Photoconductor life varies according to the type of printing (continuous, intermittent).

## Dimensions/Weight

- Not packaged
- Dimensions : 389 (W) x 105 (D) x 69 (H) (mm)
  - Weight : Approx. 780g (Photoconductor unit only)
- Packaged
- Dimensions : 456 (W) x 320 (D) x 187 (H) (mm)
  - Weight : Approx. 2,180g (includes all components)

## Storage and Transport Environment

Same as Developer cartridge.

**NOTE:** Waste toner collector, Fuser oil roll, Printhead filter are included. (must be replaced at the same time)

## 1.2.11.3 Waste Toner Collector

## Configuration and Life

Table 1-23. Waste Toner Collector Specifications

Name	Contents	Life
Waste toner collector	Waste toner collector and others	30,000 images*1

\*1: The value in standard mode (Assuming Color : 2P/J, B/W : 3P/J Color : B/W ratio = 1:1, and the image occupation rate is average 10% (TBD) of each color)  
The life varies according to the image occupation rate and type of printing (continuous, intermittent).

## Dimensions/Weight

- Not packaged
- Dimensions : 308 (W) x 290 (D) x 54 (H) (mm)
  - Weight : TBD
- Packaged
- Dimensions : TBD
  - Weight : TBD

## Storage and Transport Environment

Same as Developer cartridge.



### 1.2.11.4 Fuser Kit

#### Configuration and Life

**Table 1-24. Fuser Kit Specifications**

Name	Contents	Life
Fuser Kit	Fuser and Second transfer roll included	80,000 sheets*1 (TBD)

\*1: In A4/LT single-sided printing.  
 B/W (3P/J) : 400,000sheets, Color (2P/J) 400,000sheets  
 The cartridge life varies according to the image occupation rate and type of printing (continuous, intermittent).

#### Dimensions/Weight

- Not packaged
  - Dimensions : TBD
  - Weight : TBD
- Packaged
  - Dimensions : TBD
  - Weight : TBD

#### Storage and Transport Environment

Same as Developer cartridge.

### 1.2.11.5 Transfer Belt Unit

#### Configuration and Life

**Table 1-25. Fuser Kit Specifications**

Name	Contents	Life
Transfer Belt Unit	Transfer belt and others	100,000 sheets (TBD)

#### Dimensions/Weight

- Not packaged
  - Dimensions : TBD
  - Weight : TBD
- Packaged
  - Dimensions : TBD
  - Weight : TBD

#### Storage and Transport Environment

Same as Developer cartridge.

## 1.3 Interface Specifications

The AcuLaser Color 2000 is equipped with the following host interfaces.

- Parallel Interface (Standard)
- Ethernet Interface (Standard)
- Optional Host Interface (Type B) - 1 slot

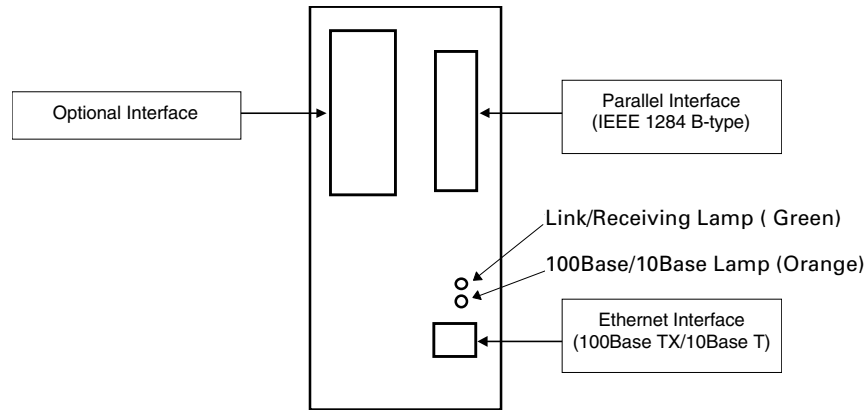

Figure 1-3. Host Interface Location

**NOTE:** Use/no use can be set for each host interface separately.

### 1.3.1 Parallel Interface Specifications

- Interface Type IEEE 1284 Bi-directional High Speed Parallel Interface
- Operating Modes Compatibility, Nibble, ECP
- Connector Type Name 57RE-40360-830B (D7A) DDK or the same class of product.
- Compatible Plug Amphenol or comparable products.

The initial value for this printer Device ID is as shown below. In the following description, in order to make it easier to read, carriage returns have been added, but actually, the character string is continuous without carriage return codes being included. The CMD items are not in the same order. MODE and STATUS items are not included. In the contents of DES items, MFG and MDL are connected by a space.

```
MFG:EPSON;
CMD:PJL,EJL,ESCPL2,ESCP9,PRPXL24-01,PCL,HPGL2-01,ESCPAGE-
04,ESCPAGECOLOR-01**1;
MDL:**2;
CLS:PRINTER;
DES:EPSON**2;;
**1 "PostScript" is added only when the PostScript 3 module is
installed.
**2AL-C2000
```

Furthermore, it is possible to redefine the MFG, MDL, DES and CID in the Device ID. Also, the CID Field does not respond with the default value, but does respond with the defined character string if it has been redefined. The Device ID when redefined is as follows. Places with \*\*\*\*\* are the user defined character strings.

```
MFG:*****;
CMD:PJL,EJL,ESCPL2,ESCP9,PRPXL24-01,PCL,HPGL2-01,ESCPAGE-
04,ESCPAGECOLOR-01**1;
MDL:*****;
CLS:PRINTER;
DES:*****;
CID:*****;
```

### 1.3.2 Ethernet Interface Specifications

- Interface Types:  
10Base T, 100Base TX, Half Duplex, Full Duplex: auto switching when the power is turned On.
- Communication Protocols
  - IPX/SPX (IPX, SPX, NCP, RIP, SAP, PrintServer, RemotePrinter, NDS, SNMP, ENPC)
  - NetBIOS (SMB)  
NetBEUI
  - TCP/IP (IP, UDP, Port9100, TCP, LPR, FTP, TELNET, ARP, ICMP, RARP, BOOTP, DHCP, HTTP, IPP, SNMP, ENPC)
  - AppleTalk (ELAP, DDP, ATP, PAP, AARP, NBP, ZIP, RTMP, SNMP, ENPC)
- ENPC : EPSON Network Peripheral Control Protocol
- IPP: Internet printing protocol
- Connector Name RJ45
- Compatible Cable 2-pair STP (10Base T, 100Base TX)

In order to conform to FCC Class B, EN55022 Class B and VCCI Class B, a shielded type cable should be used.

**Table 1-26. Pin Arrangement**

Pin	Signal Name	I/O	Pin	Signal Name	I/O
1	Tx+	O	5	N.C.	-
2	Tx-	O	6	Rx-	I
3	Rx+	I	7	N.C.	-
4	N.C.	-	8	N.C.	-

- Entity Type : See Type B interface specifications.

### 1.3.3 Optional Interface Specifications

This printer includes one Type B optional interface slot as standard equipment.

- Main System Type:  
MTP600dpi, PW5100dt600dpi, PRG(\*\*\*\*\*)rev, AP1300ma, SPD0fast,D4  
*NOTE: \*\*\*\*\*is the ROM version.*
- Printer Name: Same as the Product Name when shipped from the factory.
- Product Name: Product name AL-C2000
- Emulation Type: See the following table.
- Entity Type: See the following table.

**Table 1-27. Entity Type**

Emulation	Emulation Type	Entity Type
PS*	POSTSCRIPT-00* <sup>1</sup>	LaserWriter* <sup>1</sup>
ESC/Page Color	ESCPAGECOLOR-01	EPSONPAGECOLOR1
ESC/Page	ESCPAGE-04	
LJ4	PCL5E-00	EPSONPCL5
I239X	PRPXL24-01	EPSONPRPXL24
GL2	HPGL2-01	EPSONHPGL2
FX	ESCP9	EPSONFX
ESCP2	ESCPL2	EPSONLQ2

\*1: Added when the PostScript 3 module is installed.

- Emulation Type  
<If Emulation is set to AUTO>
  - When PS is not started: AUTO (Emulation Types 1, 2, 3 . . .)
  - When PS is started: EJP (POSTSCRIPT-00, other Emulation Types 1, 2, 3 . . .)
- <If Emulation is Fixed,>

- EJP (Default Emulation Type, other Emulation Types 1, 2, 3, . . .)
- Entity Type
  - <If Emulation is set to AUTO>
    - When PS is not started: AUTO (Emulation Types 1, 2, 3 . . .)
    - When PS is started: EJP (POSTSCRIPT-00, other Emulation Types 1, 2, 3 . . .)
  - <If Emulation is Fixed>
    - The Default Emulation Type and EPSONPAGECOLOR1 are returned.

## 1.4 Control Panel

### 1.4.1 Exterior View and Names

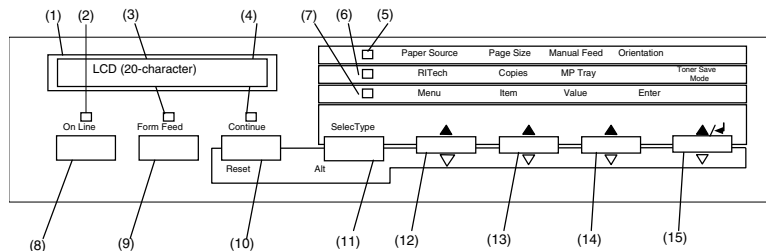

**Table 1-28. Control Panel Description**

	Name	Remarks
1	LCD Panel	1 line x 20 characters (5 x 7 dot matrix)
2	On Line LED	Color Green
3	Data LED	Color Yellow
4	Continue LED	Color Red
5	One Touch Setting Mode 1 LED	Color Green
6	One Touch Setting Mode 2 LED	Color Green
7	SelecType Mode LED	Color Green
8	On Line Switch	
9	Form Feed Switch	
10	Continue Switch	
11	SelecType/Alt Switch	Doubles as a shift switch.
12	Menu Selection Switch	
13	Item Selection Switch	
14	Value Selection Switch	
15	Enter Switch	

In printers for Taiwan, China and Korea, the panel sheet character string is displayed in Taiwanese, Chinese or Korean, respectively.

#### 1.4.1.1 LED Description

##### LCD (Liquid Crystal Display) (A)

One-line display for 20 characters (5 x 7 dot matrix)  
Normally displays printer status. In panel setting mode, LCD displays various setting values.

##### On Line LED (B)

- On: The printer is on-line.
- Off: The printer is a pause status.

##### Form Feed LED (C)

- On: Unprinted data remains in the printer. However, the lamp is not lit if the remaining data is not effective print data but other data such as control codes including commands.
- Off: No effective print data remains in the printer. If control codes are not terminated, the indicator lights up.
- Blinking: The printer is processing data.

##### Continue LED (D)

- Blinking: An error has occurred which can be cleared by pressing the Continue button.

##### One Touch Setting Mode 1 LED (E)

- On: OneTouch mode 1 is enabled. The following 4 items can be set in this mode:  
"Paper Source", "Paper Size", "Manual Feed", "Orientation"

---

### OneTouch Mode 2 LED (F)

---

- On: OneTouch mode 2 is enabled. The following 4 items can be set in this mode:  
 "RITech", "Copies", "Mp Tray Size", "Toner Save Mode"

---

### SelecType Mode (G)

---

- On: SelecType mode is enabled.

---

### All LEDs

---

- All LEDs come on when a service-call error has occurred.

## 1.4.2 Button Functions

---

### On Line button (H)

---

When the printer is on-line, pressing this button puts the printer in off-line to prevent printing. Pressed during panel setting mode, it immediately terminates the setting mode and brings the printer back to on-line status.

---

### Form Feed button (I)

---

If the Form Feed lamp is lit in off-line status, pressing this button causes the printer to print a page of data. If data for multiple pages has been received, it is printed. If the Form Feed LED is lit because the control codes are not terminated, data received up to that point is printed. The printer does not eject paper when the Form Feed LED is on.

---

### Continue button (J)

---

While the Continue LED is on, pressing this button clears the error. Also, a warning message indicated during on-line status can be cleared by pressing this button.

---

### SelecType button (K) (or Shift button)

---

Used to select OneTouch mode 1 / OneTouch mode 2 / SelecType mode, as follows:

- The first push of the button puts the printer in OneTouch mode 1.
- Pressing this button in the OneTouch mode 1 puts the printer in OneTouch mode 2.
- Pressing this button in the OneTouch mode 2 activates the SelecType mode to enter the initial level of SelecType mode. (The "Test Menu" appears.)

---

### Menu button (L)

---

- Pressing this button activates the SelecType mode. The initial level of the mode ("Test Menu") appears. In the SelecType mode, this button is used to select the setting menu, the primary level of the mode.
- In OneTouch mode 1, used to select the value for "Paper Source".
- In OneTouch mode 2, used to select the item for "RITech".
- In SelecType mode, used to select the setting menu.

**NOTE:** If this button is pressed with the Shift button held down, setting values and items scroll backward.

---

### Item button (M)

---

Pressing this button brings up the item that was last selected.

- In OneTouch mode 1, this button is used to select the value for "Paper Size".
- In OneTouch mode 2, this button is used to select the value for "Copies".
- In SelecType mode, this button is used to select the setting item.

**NOTE:** If this button is pressed with the Shift button held down, setting values and items scroll backward.

---

**Value button (N)**

---

Pressing this button enables the item that was last selected.

- In OneTouch mode 1, used to select the value for "Manual Feed".
- In OneTouch mode 2, used to select the value for "MP Tray Size".
- In SelecType mode, used to select the value for the currently selected setting item. The next available value for the item is indicated.

**NOTE:** *If this button is pressed with the Shift button held down, setting values and items scroll backward.*

---

**Enter button (O)**

---

Pressing this button generates "Status Sheet" in "Test Menu".

- In OneTouch mode 1, used to select the value for "Orientation".
- In OneTouch mode 2, used to select the value for "Toner Save Mode".
- In SelecType mode, the setting value is confirmed and printing or other functions are activated.

**NOTE:** *If this button is pressed with the Shift button held down, setting values and items scroll backward.*

---

**Reset button (Continue button + Alt button) (K + J)**

---

Pressing this button with the Alt button held down causes the printer to stop printing and reset. After the message "Reset" is indicated on the LCD, if the both buttons are kept pressed for more 5 seconds, "Reset All" is indicated and warm boot is performed.

### 1.4.3 One Touch Setting Modes

In the AcuLaser Color 2000, One Touch Setting Modes are as follows.

- One Touch Setting Mode 1 (from left)
  - Paper Source
  - Page Size
  - Manual Feed
  - Orientation
- One Touch Setting Mode 2 (from left)
  - RItech
  - Copies
  - MP Tray Size
  - Toner Save Mode

## 1.4.4 Panel Setting Item List

### Test Menu

Item	Value
Status Sheet	
Network Status Sheet* <sup>1</sup>	
AUX Status Sheet* <sup>2</sup>	
PS3 Status Sheet* <sup>3</sup>	
PS3 Font Sample* <sup>3</sup>	
ESC/Page Font Sample* <sup>4</sup>	
LJ4 Font Sample	
ESCP2 Font Sample	
FX Font Sample	
I239X Font Sample	

\*1: Displayed and can be executed only when the Network I/F=On.

\*2: Displayed and can be executed only when the printer is equipped with Level 3 compatible Type B host interface and AUX I/F=On at start-up.

\*3: Displayed and can be executed only when the Optional PostScript 3 module is installed.

\*4: Not displayed in the panel. It can be set in EJL. It is not open to users.

### Emulation Menu

Item	Value
Parallel	Auto, LJ4, ESCP2, FX, I239X, PS3* <sup>1</sup> , GL2
Network	Auto, LJ4, ESCP2, FX, I239X, PS3* <sup>1</sup> , GL2
AUX* <sup>2</sup>	Auto, LJ4, ESCP2, FX, I239X, PS3* <sup>1</sup> , GL2

\*1: Displayed and can be selected only when the Optional PostScript 3 module is installed.

\*2: Displayed and can be selected only when the Type B host interface is installed.

### Printing Menu

Item	Value
Paper Source	Auto, MP, LC1, LC2* <sup>1</sup>
Page Size	A4, A5, B5, LT, HLT, GLT, EXE, MON, C10, DL, C5, C6, IB5, CTM* <sup>2</sup>
Wide A4	Off, On
Orientation	Port, Land (Out Bin setting does not exist)
Copies	1 - 999
Quantity* <sup>3</sup>	1 - 999
Manual Feed	Off, On
Resolution	600, 300
Skip Blank Page* <sup>4</sup>	Off, On
Auto Eject Page	Off, On
Duplex* <sup>5</sup>	Off, On
Binding* <sup>5</sup>	Long Edge, Short Edge
Start Page* <sup>5</sup>	Front, Back

\*1: Displayed and can be selected only when the optional lower paper cassette is installed.

\*2: Paper size for CTM (custom) is minimum 92 x 148mm and maximum 216 x 297mm.

\*3: Not displayed in the panel. It can be set in EJL or PJJ. It is not stored in NVRAM.

\*4: Valid for PCL5e, ESC/Page, ESC/P2, FX and I239X.

\*5: Displayed and can be set only when the Duplex unit is installed.

### Tray Menu

Item	Value
MP Mode* <sup>1</sup>	Normal, Last
MP Tray Size	A4* <sup>2</sup> , A5, B5, LT, HLT, GLT, EXE, MON, C10, DL, C5, C6, IB5



LC1 Size* <sup>3</sup>	A4, LT
LC2 Size* <sup>4</sup>	A4, LT
MP Type	<u>Plain</u> , Letterhead, Recycled, Color, Trnsprncy, Labels
LC1 Type	<u>Plain</u> , Recycled, Color
LC2 Type* <sup>4</sup>	<u>Plain</u> , Recycled, Color

\*1: This function becomes valid for the next job immediately after the setting is changed.

\*2: LT is the default value of Letter type controller and A4 is the default value of A4 type controller.

\*3: Displayed only. Cannot be changed.

\*4: Displayed only when the optional lower paper cassette is installed. Paper size is displayed only.

## Config Menu

<u>Item</u>	<u>Value</u>
RI Tech	<u>On</u> , Off
Toner Save	<u>Off</u> , On (Density setting does not exist)
Top Offset	-99.0 - <u>0.0</u> - 99.0 mm step 0.5 mm
Left Offset	-99.0 - <u>0.0</u> - 99.0 mm step 0.5 mm
T Offset B* <sup>1</sup>	-99.0 - <u>0.0</u> - 99.0 mm step 0.5 mm
L Offset B* <sup>1</sup>	-99.0 - <u>0.0</u> - 99.0 mm step 0.5 mm
Size Ignore	<u>Off</u> , On
Auto Cont	<u>Off</u> , On
Page Protect	<u>Auto</u> , On
Image Optimum	<u>Auto</u> , Off, On
Paper Type	<u>Normal</u> , Thick, Trnsprnc

\*1: Displayed only when the optional duplex unit is installed. Paper size is displayed only.

## Setup Menu

Item	Value
Time Out	0, 5 - <u>60</u> - 300 step 1
Standby*1	<u>Enable</u> , Disable
Lang	<u>English</u>
Lang	Français
Sprache	Deutsch
LINGUA	ITALIANO
LENG	ESPAÑOL
SPRÅK	SVENSKA
Sprog	Dansk
Taal	Nederl.
KIELI	SUOMI
Líng	Português
Panel Lock*2	<u>Off</u> , On
C Toner*3	E****F, E***□F, E**□□F, E*□□□F, E□□□□F
M Toner*3	E****F, E***□F, E**□□F, E*□□□F, E□□□□F
Y Toner*3	E****F, E***□F, E**□□F, E*□□□F, E□□□□F
K Toner*3	E****F, E***□F, E**□□F, E*□□□F, E□□□□F
Toner Out	<u>Stop</u> , Continue
Photoconductor	100% - 0%
Total Pages*3	0 - 99999999
Color Pages*3	0 - 99999999

B/W Pages\*3

0 - 99999999

SelectType Init

\*1: STANDBYTIME command in EJL is also supported. The default value is 60 minutes.

\*2: Not displayed in the panel. It is not listed in the Status Sheet either. It can be set by EJL or EpsonNet WebAssist etc..

\*3: This item is display only and setting cannot be changed.

## Parallel Menu\*1

Item	Value
Parallel I/F	<u>On</u> , Off
Speed	<u>Fast</u> , Normal
Bi-D	Nibble, <u>ECP</u> , Off <Default value changed>
Buffer Size	<u>Normal</u> , Maximum, Minimum

\*1: If this setting is changed, it becomes valid after warm boot or at power on again. However, reading with EJL, and printing on the status sheet for themselves are immediately reflected.

## Network Menu\*1

<i>Item</i>	<i>Value</i>
Network I/F	<u>On</u> , Off
Network Config	<u>No</u> , Yes
Get IPAddress*2	Panel, <u>Auto</u> , PING <Default value changed>
IP Byte 1*2	0 - <u>192</u> - 255
IP Byte 2*2	0 - <u>168</u> - 255
IP Byte 3*2	0 - <u>192</u> - 255
IP Byte 4*2	0 - <u>168</u> - 255
SM Byte 1*2	0 - <u>255</u>
SM Byte 2*2	0 - <u>255</u>
SM Byte 3*2	0 - <u>255</u>
SM Byte 4*2	<u>0</u> - 255
GW Byte 1*2	0 - <u>255</u>
GW Byte 2*2	0 - <u>255</u>
GW Byte 3*2	0 - <u>255</u>
GW Byte 4*2	0 - <u>255</u>
Buffer Size	<u>Normal</u> , Maximum, Minimum

\*1: If this setting is changed, it becomes valid after warm boot or at power on again. However, reading with EJL, and printing on the status sheet for themselves are immediately reflected.

\*2: Displayed and can be selected only when Network Config=Yes. Always listed in the Status Sheet.

## AUX Menu\*1 \*2

<i>Item</i>	<i>Value</i>
AUX I/F	<u>On</u> , Off
AUX Config*3	<u>No</u> , Yes
Get IPAddress*3*4	Panel, Auto, PING
IP Byte 1*3*4	0 - 255
IP Byte 2*3*4	0 - 255
IP Byte 3*3*4	0 - 255
IP Byte 4*3*4	0 - 255
SM Byte 1*3*4	0 - 255
SM Byte 2*3*4	0 - 255
SM Byte 3*3*4	0 - 255
SM Byte 4*3*4	0 - 255
GW Byte 1*3*4	0 - 255
GW Byte 2*3*4	0 - 255
GW Byte 3*3*4	0 - 255
GW Byte 4*3*4	0 - 255
NetWare†*3*4	On, Off
AppleTalk*3*4	On, Off
NetBEUI*3*4	On, Off
AUX Init*3*4	
Buffer Size	<u>Normal</u> , Maximum, Minimum

\*1: If this setting is changed, it becomes valid after warm boot or at power on again. However, reading with EJL, and printing on the status sheet for themselves are immediately reflected.

\*2: Displayed only when the Type B host interface is installed.

\*3: Displayed and can be selected/executed only when Level 3 compatible Type B host interface is installed. This automatically returns to AUX Config= No when the printer status changed to On-line.

\*4: Displayed and can be selected/executed only when AUX Config= Yes is selected.

## ESC/Page Menu\*1

Item	Value
Auto CR	<u>On</u> , Off
Auto FF	<u>On</u> , Off
CR Function	<u>CR</u> , CR+LF
LF Function	<u>CR+LE</u> , LF
FF Function	<u>CR+FE</u> , FF
Error Code	<u>Ignore</u> , Space
Avoid Error	<u>Off</u> , On
PGI	<u>On</u> , Off
TriColorSpace	<u>Normal</u> , sRGB
CM Media Type	<u>Off</u> , Opt1, Opt2

\*1: Not displayed on the panel or Status Sheet. Can be specified by EJL.

## LJ4 Menu

Item	Value
Font Source	<u>Resident</u> , Download*1, ROM A*2, ROM B*2
Font Number	<u>0</u> - available (Max 65535)
Pitch*3	0.44 - <u>10.00</u> - 99.99 cpi step 0.01cpi
Height*3	4.00 - <u>12.00</u> - 999.75 pt step 0.25 pt
SymSet	<u>IBM-US</u> , Roman-8, Roman-9, ECM94-1, 8859-2 ISO, 859-9 ISO, 8859-10 ISO, 8859-15 ISO, PcBlt775, IBM-DN, PcMultiling, PcE.Europe, PcTk437, PcEur858, Pc1004, WiAnsi, WiE.Europe, WiTurkish, WiBALT, DeskTop, PsText, VeInternati, VeUS, MsPublishin, Math-8, PsMath, VeMath, PiFont, Legal, UK, ANSIASCII, Swedis2

Italian, Spanish, German, Norweg1, French2, Windows, McText, Pclcelandic, Pclt774, PcTurk1, PcPortugues, PcEt850, PcTurk2, PcCanFrench, PcSI437, PcNordic, 8859-3 ISO, 8859-4 ISO, WiBaltic, WiEstonian, WiLatvian, Mazowia, CodeMJ, BpBRASCII, BpAbicomp, PcGk437, PcGk851, PcGk869, 8859-7 ISO, WiGreek, Europe3, PcCy855, PcCy866, Pclt866PcUkr866, Pclit771, 8859-5 ISO, WiCyrillic, Bulgarian, Hebrew7, 8859-8 ISO, Hebrew8, PcHe862, Arabic8, PcAr864, 8859-6 ISO, OCR A, OCR B

Form 5 - 64 - 128 Lines

Source SymSet 0 - 277 - 3199

Dest SymSet 0 - 277 - 3199

CR Function CR, CR+LF

LF Function LE, CR+LF

Tray Assign 4, 4K, 5S

\*1: Displayed only when a download font exists.

\*2: Displayed only when a optional font ROM is inserted to the ROM socket.

\*3: One or the other is displayed, depending on the font type selected. In the case of a fixed pitch font, "Height" is displayed and in the case of a proportional pitch font, "Pitch" is displayed. Both of Pitch and Height may be displayed at the same time. (When FontSource for Font Number is changed while PCL5 does not operate internally.)

## GL2 Menu

<i>Item</i>	<i>Value</i>
GLMode	<u>LJ4GL2</u> , GLlike
Scale	<u>Off</u> , A0, A1, A2, A3
Origin	<u>Corner</u> , Center
Pen	<u>Pen0</u> , Pen1, Pen2*1, Pen3*1, Pen4*1, Pen5*1, Pen6*1
End	<u>Butt</u> , Square, Triangular, Round
Join	<u>Mitered</u> , Miteredbeveled, Triangular, Round, Beveled, None
Pen0	0.05 - <u>0.35</u> - 5.00 mm step0.05mm
Pen1	0.05 - <u>0.35</u> - 5.00 mm step0.05mm
Pen2†1	0.05 - <u>0.35</u> - 5.00 mm step0.05mm
Pen3†1	0.05 - <u>0.35</u> - 5.00 mm step0.05mm
Pen4†1	0.05 - <u>0.35</u> - 5.00 mm step0.05mm
Pen5†1	0.05 - <u>0.35</u> - 5.00 mm step0.05mm
Pen6†1	0.05 - <u>0.35</u> - 5.00 mm step0.05mm

\*1: Displayed only when GLlike mode is selected.

## PS3 Menu\*1

<i>Item</i>	<i>Value</i>
Error Sheet	<u>Off</u> , On
Coloration	<u>Color</u> , Mono, TrueCol.
Image Protect	<u>Off</u> , On

\*1: Displayed only when optional PostScript3 is installed.

## ESCP2 Menu

<i>Item</i>	<i>Value</i>
Font	<u>Courier</u> , Prestige, Roman, Sans serif, Roman T, Orator S, Sans H, Script, OCR A, OCR B
Pitch	<u>10cpi</u> , 12cpi, 15cpi, Prop.
Condensed	<u>Off</u> , On
T.Margin	0.40 - <u>0.50</u> - 1.50 inch step 0.05 inch
Text	1 - <u>66</u> - available (Max:67) Lines
CG Table	<u>PcUSA</u> , Italic, PcMultilin, PcPortugue, PcCanFrenc, PcNordic, PcTurkish2, Pclcelandic, PcE.Europe, BpBRASCII, BpAbicom, Roman-8, PcEur858, ISO Latin1, 8859-15ISO, PcSI437, PcTurkish1, 8859-9 ISO, Mazowia, CodeMJK, PcGk437, PcGK851, PcGk869, 8859-7 ISO, PcCy855, PcCy866, Bulgarian, PcUkr866, Hebrew7, Hebrew8, PcAr864, PcHe862
Country	<u>USA</u> , France, Germany, UK, Denmark, Sweden, Italy, Spain1, Japan, Norway, Denmark2, Spain2, LatinAmeric, Korea, Legal
Auto CR	<u>On</u> , Off
Auto LF	<u>Off</u> , On
Bit Image	<u>Dark</u> , Light, BarCode
Zero Char	<u>0</u> , Ø

**FX Menu**

<i>Item</i>	<i>Value</i>
Font	<u>Courier</u> , Prestige, Roman, Sans serif, Script, Orator S, OCR A, OCR B
Pitch	<u>10cpi</u> , 12cpi, 15cpi, Prop.
Condensed	<u>Off</u> , On
T.Margin	0.40 - <u>0.50</u> - 1.50 inch step 0.05 inch
Text	1 - <u>66</u> - available(Max:81) Lines
CG Table	<u>PcUSA</u> , Italic, PcMultilin, PcPortugue, PcCanFrenc, PcNordic, PcTurkish2, Pclcelandic, PcE.Europe, BpBRASCII, BpAbicom, Roman-8, PcEur858, ISO Latin1, 8859-15ISO
Country	<u>USA</u> , France, Germany, UK, Denmark, Sweden, Italy, Spain1, Japan, Norway, Denmark2, Spain2, LatinAmeric
Auto CR	<u>On</u> , Off
Auto LF	<u>Off</u> , On
Bit Image	<u>Dark</u> , Light, BarCode
Zero Char	<u>0</u> , Ø

**I239X Menu**

<i>Item</i>	<i>Value</i>
Font	<u>Courier</u> , Prestige, Gothic, Orator, Script, Presentor, Sans serif
Pitch	<u>10cpi</u> , 12cpi, 15 cpi, 17 cpi, 20 cpi, 24 cpi, Prop.
Code Page	<u>437</u> , 850, 858, 860, 863, 865
T.Margin	0.30 - <u>0.40</u> - 1.50 inch step 0.05 inch
Text	1 - <u>67</u> - available (Max: 81) Lines

Auto CR	<u>Off</u> , On
Auto LF	<u>Off</u> , On
Alt. Graphics	<u>Off</u> , On
Bit Image	<u>Dark</u> , Light
Zero Char	<u>0</u> , Ø
Character Set	1, <u>2</u>

**Support Menu\*1**

<i>Item</i>
HDD Format
PS3 HDD Init*2

\*1: This setting menu is displayed only when the Support Mode has been activated by hidden operation when the power is turned on. This menu is not displayed if optional HDD does not exist.

\*2: Displayed and can be executed only when both of PS3 and HDD are installed.

**Maintenance Menu\*1**

<i>Item</i>	<i>Value</i>
Engine Status Sheet	
Error Log Clear	

\*1: This setting menu is displayed only when the Maintenance Mode has been activated by hidden operation when the power is turned on. Always displayed in English regardless of the Lang setting in the Setup Menu.

A list of user setting items which are not included in the Setup Menu are shown below. Depending on the panel initialization menu, these are not cleared when the settings are initialized.

**Table 1-29.**  
**User Setting Items Excluded from the Setup Menu**

Setting Item	Setting Value	Default Value	Setting Method
PrinterName	32-byte character string	(TBD)	EJL, PrinterName command
MFG in the Device ID	32-byte character string	(Undefined)	EJL
MDL in the Device ID	32-byte character string	(Undefined)	EJL
DES in the Device ID	32-byte character string	(Undefined)	EJL
CID in the Device ID	32-byte character string	(Undefined)	EJL

## 1.4.5 Explanation of Each Setting Menu and Items

The following explains concerning items which are unique specifications in the AcuLaser Color 2000.

### 1.4.5.1 Printing Menu

---

#### Paper Source

---

This selects the paper feeder in the case that the Paper Type = Normal.

- Auto Paper is fed from the paper feeder where the specified type and size of paper are kept.
- MP Paper is fed from the MP tray.
- LC1 Paper is fed from the first level cassette.
- LC2 Paper is fed from the second level cassette.

**NOTE:** When the paper size setting is "Envelope" (IB5, C10, C5, DI, MON, C6), the paper feeder used is always the MP tray.

**NOTE:** When the Paper Type = Thick or Trnsprnc, the paper feeder used is always the MP tray

---

#### Quantity

---

This sets the number of copies when copies are being printed in set units. The specification in this setting has priority over the Copies setting. Therefore, if the Quantity is 2 or greater, the setting value specified by Copies becomes invalid. Collate printing is performed using RAM or HDD. When optional HDD is not installed, Quantity setting can be used if RAM capacity is over 64MB.

This setting is specified only by PjL, EJL, ESC/Page or ESC/Page-Color command and the setting value cannot be stored in memory. If the data for one print job could not be stored in the printer memory, the warning Collate was disabled is displayed and one set only is printed out.

### 1.4.5.2 Tray Menu

#### MP Type, LC1 Type, LC2 Type

This specifies the type of paper set in the MP tray, LC1/2 Cassette.

Setting Value	Setting Contents	Engine Control	Available Tray
Plain	Plain Paper (copy paper etc.)	Plain paper	MP, LC1&2
Letterhead	Letterhead	Plain paper	MP
Recycled	Recycled paper	Plain paper	MP, LC1&2
Color	Color paper	Plain paper	MP, LC1&2
Trnsprncy	OHP transparency	OHP (half speed)	MP
Labels	Label paper	Label paper (half speed)	MP

<When the setting of Paper Type is envelopes (IB5, C10, C5, DL, MON, C6)>

The paper feeder used is always the MP tray. Engine control is performed as envelopes.

<When Page Size=A5, B5, HLT, GLT, GLG, EXE, F4, CTM>

The paper feeder used is always the MP tray. Paper Type setting is prioritized in selecting engine control mode. MP Type setting is used when Paper Type=Normal.

<If Page Size=A4, LT>

- When Paper Type = Normal

If Paper Source = Auto,

From the paper feeders where the paper type specified by a language and available tray in the table above matches, the paper feeder which also matches the specified paper size is selected.

If Paper Source = MP, LC1 or LC2, specified paper feeder is selected

- When Paper Type = Thick, Transprnc

The paper feeder used is always the MP tray

- Engine control

Paper Type setting always takes priority.

When Paper Type=Normal, engine control is performed based on the specified value for the selected tray.

**NOTE:** The type of paper specified when selecting a paper feeder is specified only by a command in ESC/Page or ESC/Page-Color or LJ4.

**NOTE:** "Bond" is not used to avoid the confusion with "Thick".

### 1.4.5.3 Config Menu

#### RITech

See the description in the RITech item in the 97SIS-565 Basic Page-Printer Operating Specifications. This is an outline correction function which is equivalent to that in a single color page printer in B/W printing. In color printing, When in the AcuLaser Color Halftoning mode, outline correction is accomplished by the CRIT function.

#### Toner Save

See the description in the Toner Save item in the 97SIS-565 Basic Page-Printer Operating Specifications. During color printing, by controlling the half-tone growth and by printing with a low density, toner consumption is reduced.

#### Paper Type

This sets the printing speed and CM to match the type of paper used.

Normal (Copy paper, recycled paper, J paper, etc.)



- Cases where Paper Source = MP, LC1, LC2 or Paper Source = Auto, and the type of paper used is not specified.

Printing Speed: Standard Mode

CM: As shown below in accordance with the CM Media Type value in the ESC/Page Menu. CM Media Type: CM Off: Plain Paper Opt1: Option1 Opt2: Option2

- Cases where Paper Source = Auto and the type of paper used is specified.

Printing Speed :As shown below in accordance with the type of paper set in the paper feeder that actually feeds the paper (set according to the MP, LC1/2 Type in the Tray Menu).

<b>Paper Type</b>	<b>Printing Speed</b>
Plain	Standard Mode
Letterhead	Standard Mode
Recycled	Standard Mode
Color	Standard Mode
Trnsprncy	Half-speed Mode
Labels	Half-speed Mode

CM : As shown below in accordance with the CM Media Type value in the ESC/Page Menu

<b>CM Media Type</b>	<b>CM</b>
Off *1	See Note 1 below.
Opt1	Option1
Opt2	Option2

\*1: When the CM Media Type is Off, the setting is as follows in accordance with the type of paper selected.

<b>Type of Paper</b>	<b>CM</b>
Plain	Plain Paper
Letterhead	Plain Paper
Recycled	Plain Paper
Color	Plain Paper
Trnsprncy	OHP
Labels	Plain Paper

At this time, the type of paper which decides the printing speed and the type of paper that decides the CM may not match, so caution is necessary. In such a case, the Check Paper Type message is displayed.

- Thick (Envelope, Thick Paper, etc.)  
Printing Speed : Half-speed Mode  
CM : Plain Paper
- Trnsprnc (OHP Sheet)  
Printing Speed : Half-speed Mode  
CM : OHP

When the paper size setting is Envelop or HAGAKI (Japanese only), printing is done by the engine control for envelope or HAGAKI without relation to this value. Half speed mode is selected when the paper size is CTM and paper length is shorter than 210mm.

### 1.4.5.4 Setup Menu

---

#### C Toner

---

The remaining C (Cyan) toner level is displayed in 5 steps (display only, exclusive readout).

E\*\*\*\*F : 100% ≥ Remaining Toner > 75%

E\*\*\* F : 75% ≥ Remaining Toner > 50%

E\*\* F : 50% ≥ Remaining Toner > 25%

E\* F : 50% ≥ Remaining Toner > 0%

E F : Remaining Toner = 0%

**NOTE:** *(This can be included in the manual.)*

*The data of remaining toner is stored in the engine. Engine issues Toner empty error etc. for each toner based on the stored data.*

---

#### M Toner

---

The remaining M (Magenta) toner level is displayed in 5 steps (display only, exclusive readout). The specifications are the same as for the C Toner.

---

#### Y Toner

---

The remaining Y (Yellow) toner level is displayed in 5 steps (display only, exclusive readout). The specifications are the same as for the C Toner.

---

#### K Toner

---

The remaining K (Black) toner level is displayed in 5 steps (display only, exclusive readout). The specifications are the same as for the C Toner.

---

#### Photoconductor

---

This displays the remaining life of the Photoconductor Unit in %. (display only, exclusive readout) 100% (New) - 20% (Warning) - 0% (end of the service life). The value is automatically reset when installing new Photoconductor Unit. Read the rotation value from printer engine and takes 3200 as 100% to represent the photoconductor unit's service life. Even if the rotation value exceeds 3200, it is regarded as 3200.

---

#### Total Pages

---

This displays the number of pages printed by the printer up to the present time. (display only) When the number exceeds 99999999, the counter does not count up any more.

---

#### Color Pages

---

This displays the number of color pages only printed by the printer up to the present time. (Display only) When the number exceeds 99999999, the counter does not count up any more.

---

#### B/W Pages

---

This displays the number of single color pages only printed by the printer up to the present time. (Display only) Since in this printer this value indicates the "Total Pages" - "Color Pages," if the Total Pages exceeds 99999999, the correct value will not be displayed.

---

#### SelecType Init

---

This returns the panel setting values to the factory default. This does not reset Total Pages, Color Pages, B/W Pages, CMYK Toner Counter, Parallel/ Network/AUX Menu setting and the counters counted by engine.

### 1.4.5.5 Maintenance Menu

This setting menu is displayed, and selection enabled, only when the Maintenance Mode has been activated by hidden operation when the power is turned on. After that, if the power is turned off, then turned on again, the Maintenance Menu is deleted from the Menu (Maintenance Mode deleted = the printer has switched to the normal mode). Basically, this setting is used for maintenance by service personnel.

---

### Engine Status Sheet

---

Pressing the Enter switch starts printing of the Engine Status Sheet. If data are remaining in the language, paper is output. Be sure to enter the Maintenance Mode from a normal mode (a mode that is not the Maintenance Mode) after confirming that there are no engine related service calls, then print this sheet. The RiTech, Toner Save and Resolution values are set while the printer is started up, and the other values that are printed out are factory settings. After printing is finished, the User Default environment (settings) does not change. during printing, the contents displayed in the LCD blink.

---

### Error Log Clear

---

This clears the Error Log List stored in memory for display in the Engine Status Sheet.

## 1.4.6 Service Operations

The special service operations supported by this printer are shown below.

**NOTE:** Functions other than Hex dump and the Support Mode are not disclosed publicly for users.

**Table 1-30. Service Functions**

Function	Operating Method
Hex Dump	Turn on the power while pressing the Form Feed switch.
Support Mode	Turn on the power while pressing the Value selection switch.
Initialization of EEPROM	Turn on the power while pressing the On Line + Continue + Menu selection switches.
Panel Setting Value Initialization	Turn on the power while pressing the Continue switch.
Forced Erasure of the Flash ROM A Module	Turn on the power while pressing the Alt + Item Selection + Value Selection + Enter switches.
Program ROM Update	Turn on the power while pressing the On Line + Alt + Value Selection switches.
ROM Module Copy	Turn on the power while pressing the On Line + Alt + Enter switches.
Maintenance Mode	Turn on the power while pressing the On Line + Form Feed + Continue switches.
CPU reset when a Service Call occurs.	When a Service Call Error occurs, Press the Alt + Menu Selection + Item Selection + Value Selection + Enter switches.
Printing of the Error Sheet	Following CPU Reset after a Service Call Error occurs, press the Enter switch 2 times.

## 1.5 About RAM Expansion

---

In this printer, if there is insufficient memory, the following errors occur.

- Mem Overflow
- Image Optimum
- Need Memory
- Duplex Mem Overflow

In these cases, it may be possible to overcome the problem by one of the following methods.

1. Set the resolution on 300 dpi in the case of B/W printing.
2. If printing with color is set, change the compression format (lossy compression )
3. Make the receiving buffer size smaller.
4. Set an I/F which is not used to OFF.

However, in order to definitely avoid problems with insufficient memory, it is necessary to install more memory.

## 1.6 Engine Restrictions

### 1.6.1 Restriction on Printing Speed

1. Transfer voltage control (ATVC) / Density control  
At the following timing, process adjustment operation is performed automatically in the printer engine.  
: approx.80sec.
  - At powering on
  - Cover is opened/closed when no paper-jam occurring  
Printer covers: Front cover, Top cover (cover A), Right cover (cover B), Cassette right side cover (cover C1), Duplex cover (cover DM), Optional cassette cover (cover C2)
  - When recovering from the standby state and also 100pages has been printed or 24hours passed since previous adjustment operation performed.
2. Cooling down  
To prevent transparencies from jamming, cooling down of the Fuser is performed at the following timing.  
: approx.60sec.
  - When it meets following conditions "O" in the table before starting print on transparencies.

**Table 1-31. Cooling Down Timing**

		Rotation period of the Fuser (Sec.)*1		
		0 to 30	30 to 105	105 and above
Rotation period of the Fuser (Sec.)*2	0 to 30			○
	30 to 120		○	○
	120 to 180	○	○	○

\*1: in 3 to 30 min. before the printing

\*2: in 0 to 3 min. before the printing

### 1.6.1.1 Toner Duty Restrictions

200% (to prevent paper or transparencies from sticking to the Fuser)  
However, printing is not stopped forcibly when the duty exceeds 200% at the engine side.

## 1.7 Handling Precautions

---

### 1.7.1 Caution when there is a Power Failure

This printer is equipped internally with nonvolatile memory (E<sup>2</sup>PROM). This nonvolatile memory preserves the settings for printer functions, and if the power is cut during writing to the nonvolatile memory, the contents of the nonvolatile memory cannot be guaranteed, with the result that when the power is turned on again, or when a Reset All is executed, the panel setting values will return to the default settings, or a Service Call Error will occur.

A HDD can also be connected to this printer, but if the power is cut during writing to the HDD, the writing contents cannot be guaranteed, so a HDD error may occur.

Accordingly, in the following cases, the power should not be cut while writing to the nonvolatile memory or to the HDD.

1. From the time the power is turned on until the On Line LED lights up continuously.
2. While the On Line LED is blinking.
3. While the printer is printing (while the paper feed motor is operating).
4. When stopping printing, either it should be made Off-line or the printer should be reset.
5. While the Data LED is lighted up, or when it is blinking.

### 1.7.2 Caution Regarding High Temperature Parts

The temperature of the Fuser Unit inside the printer becomes high, so if you are opening the printer to remove a paper jam, etc., care should be taken not to touch the Fuser Unit.





**CHAPTER**

**2**

**OPERATING PRINCIPLES**

## 2.1 Mechanism Overview

The following figure is the mechanism sectional drawing that helps you understand the basic mechanism of this printer.

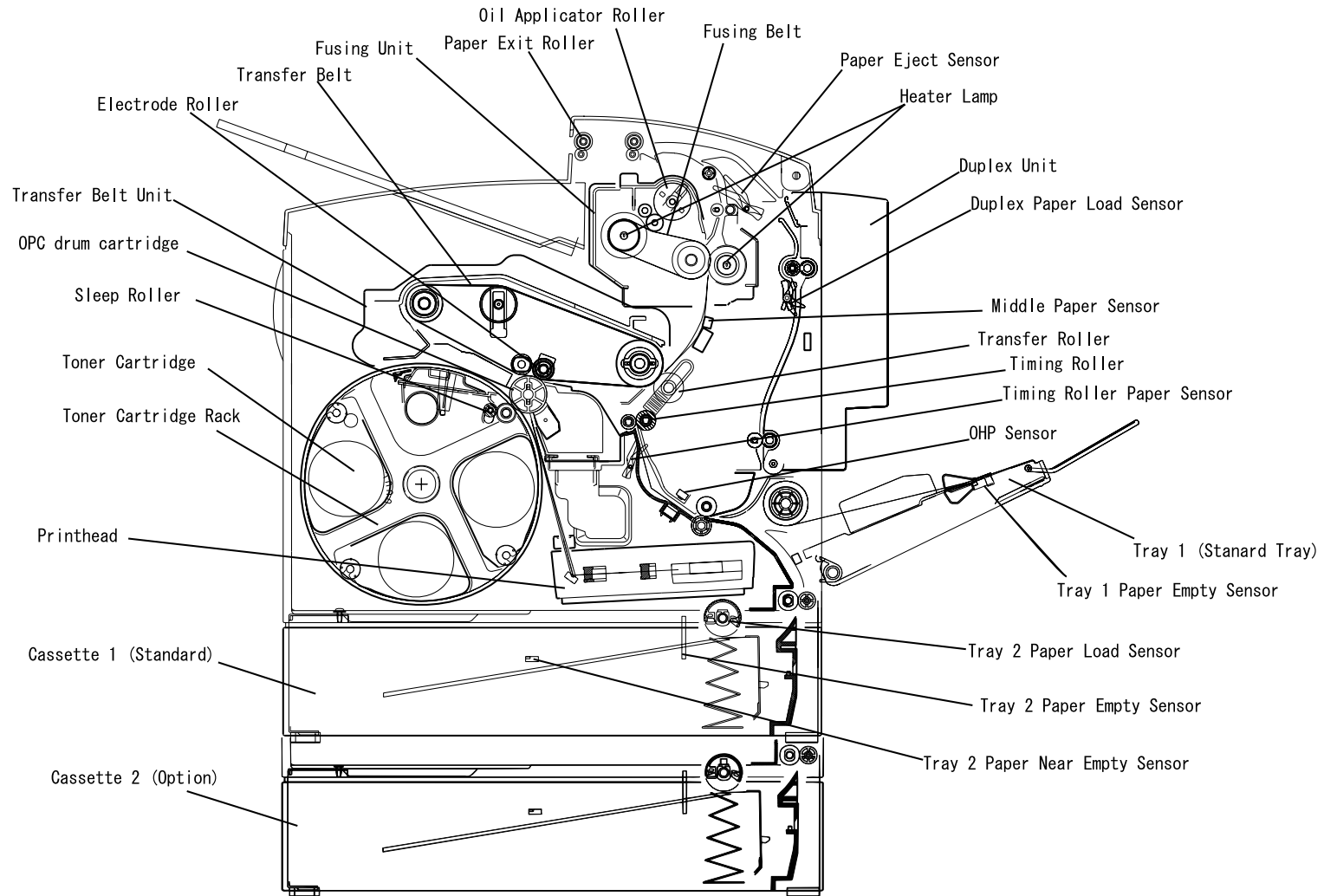

op39

Figure 2-1. Sectional Drawing

### 2.1.1 Gear Roller Arrangement

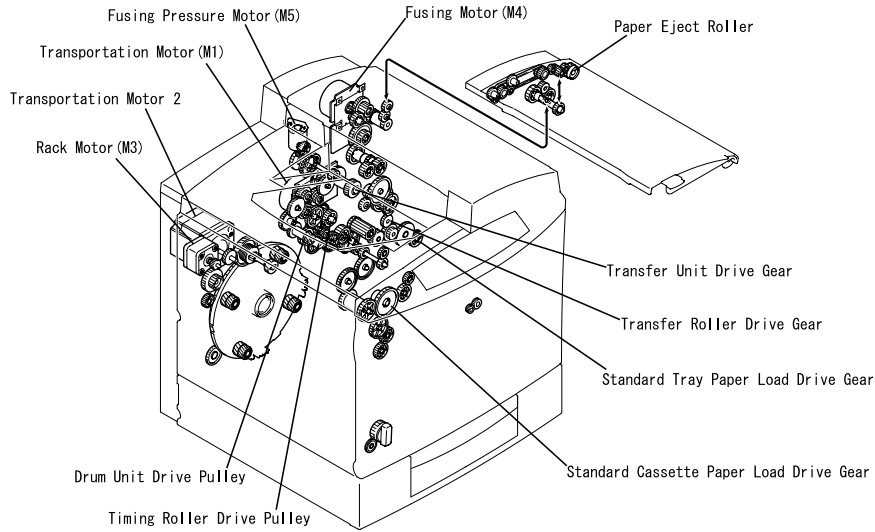

op40

**Figure 2-2. Gear Roller Arrangement**

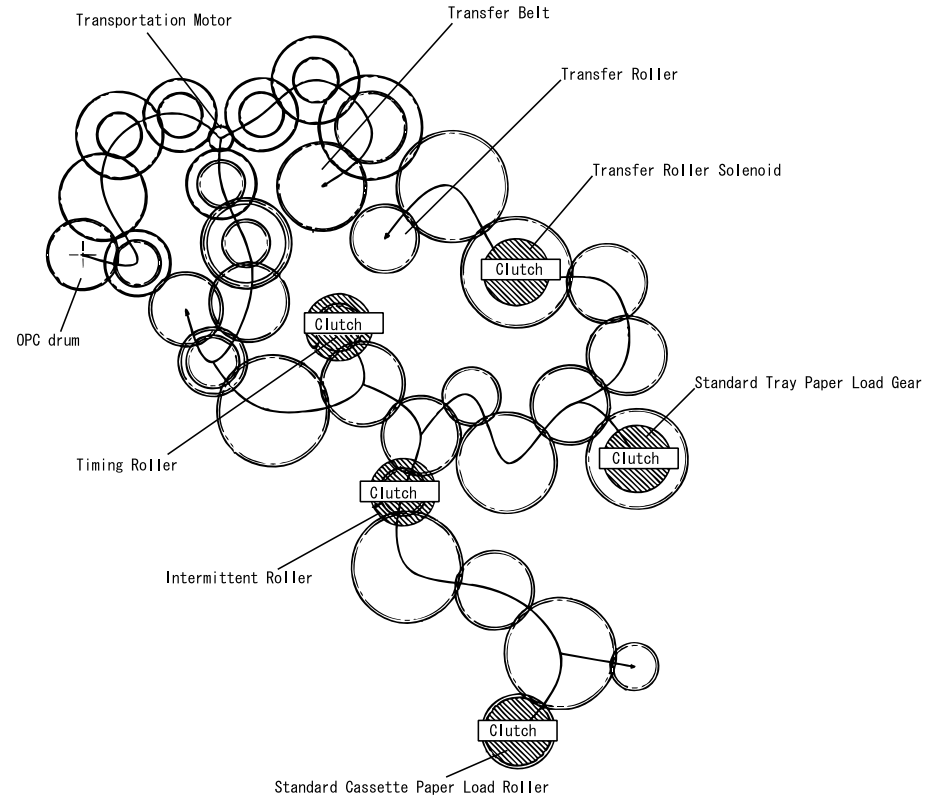

op41

**Figure 2-3. Drive Force Transmission**

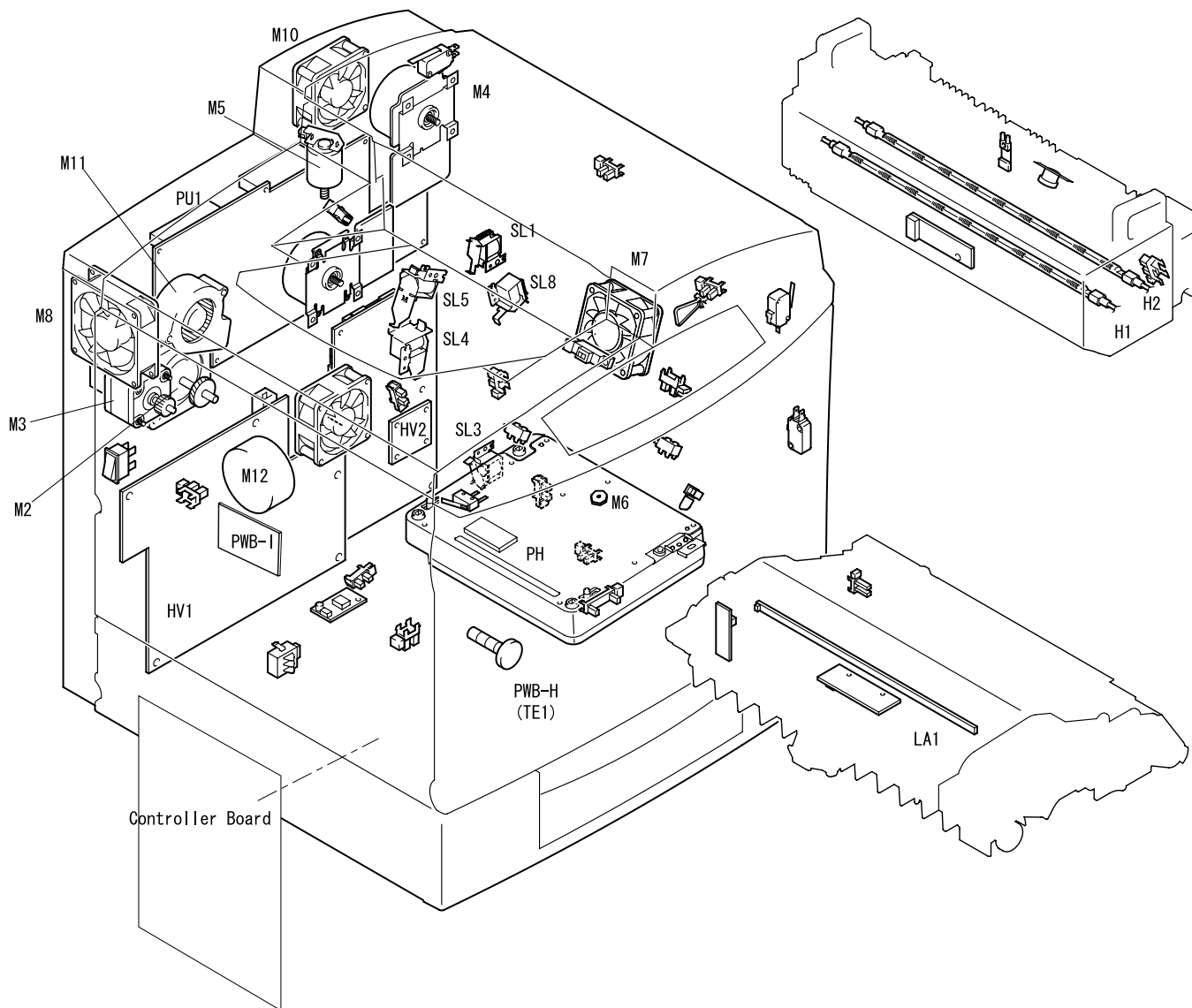

op42

Figure 2-4. Motor, Solenoid Arrangement

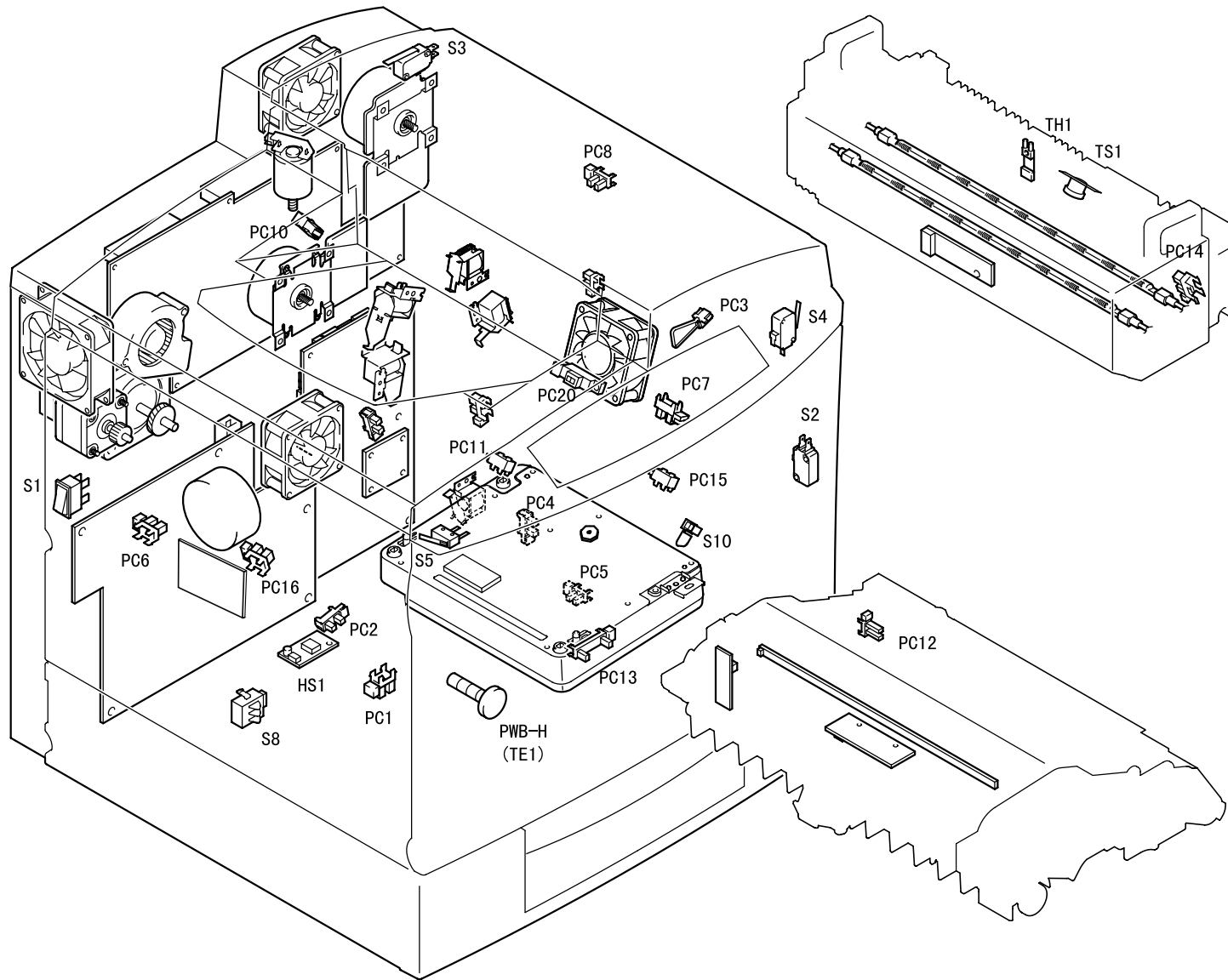

op43

Figure 2-5. Switch, Sensor Arrangement

Table 2-1. Electric Parts Name

Signal	Name
LA1	Eraser lamp
H1	Heater lamp (Heat applying roller)
H2	Heater lamp (Pressure applying roller)
HS1	Humidity sensor (Standard cassette)
HV1, 2	High pressure unit
M1	Transportation motor
M2	Development motor
M3	Rack motor
M4	Fusing motor
M5	Fusing pressure motor
M6	Polygon motor (P/H built-in)
M7	Suction fan motor
M8	Power supply fan motor
M9	Ozone fan motor
M10	Fusing fan motor
M11	Toner suction fan motor
M12	Belt cleaner motor
PC1	Standard cassette paper empty sensor
PC2	Standard cassette paper near empty sensor
PC3	Standard tray paper empty sensor
PC4	Standard cassette door open sensor
PC5	Timing roller paper sensor
PC6	Rack black position sensor
PC7	Transfer roller pressure sensor
PC8	Paper eject sensor
PC10	Fusing pressure position sensor
PC11	OPC sensor (paper path)
PC12	Transfer belt position sensor
PC13	Waste toner full sensor
PC14	Pressure roller separation sensor

Table 2-1. Electric Parts Name

Signal	Name
PC15	Standard tray upper position sensor
PC16	Belt cleaner separation sensor
PC20	Intermittent paper sensor
PH	Printhead
PU1	Power supply unit (PWB)
PWB-I	Belt cleaner control board
S1	Power supply switch
S2	Interlock switch front right
S3	Interlock switch upper
S4	Interlock switch right
S5	Interlock switch (CDRH-SW)
S8	Standard cassette paper size switch
S10	Waste toner box printhead filter switch
SL3	Standard cassette paper load solenoid
SL4	Intermittent roller solenoid
SL7	Transfer roller pressure solenoid
SL8	Standard tray paper load solenoid
TE1	Toner empty sensor (PWB-H)
TH1	Thermistor 1 (heat roller)
TS1	Thermostat 1 (heat roller)

Table 2-2. Sensors

Unit	Detection Item	Detection Method	Note
OPC	Exist / non-exist detection	Contact point conductivity check method	
	New / old detection	Fuse method	
	Installation and removal detection at power supply ON	Contact point conductivity check method	<ul style="list-style-type: none"> <li>• It can be installed and removed with the conductivity on.</li> <li>• No mechanism broken.</li> <li>• The installation and removal state is updated at cover open / close.</li> </ul>
	Used amount detection	Measures the driving period (motor rotational period)	Calculated by 30 seconds interval.
	Near end detection	Main motor driving time accumulated period	2640 count x 30 seconds = 1320 min.
	End detection	Main motor driving time accumulated period	3300 count x 30 seconds = 1650 min. After end detection, print less than 100 images (300 seconds) and stops after printing.
	EPSON genuine product detection	Non-compatible rib	Cannot be installed structurally.

Table 2-2. Sensors

Unit	Detection Item	Detection Method	Note
Fusing oil roller	Exist / non-exist detection	Contact point conductivity check method	
	Installation and removal detection at power supply ON	Contact point conductivity check method	<ul style="list-style-type: none"> <li>• It can be installed and removed with the conductivity on.</li> <li>• No mechanism broken.</li> <li>• The installation and removal state is updated at cover open / close.</li> </ul>
	New / old detection	Fuse method	
	Used amount detection	Measures the driving period (fusing motor rotational period) TBD	
	End detection	Measures the driving period (fusing motor rotational period) TBD	
	EPSON genuine product detection	Measures the driving period (fusing motor rotational period) TBD	

Table 2-2. Sensors

Unit	Detection Item	Detection Method	Note
Waste toner box	Exist / non-exist detection	Leaf switch	
	Installation and removal detection at power supply ON	Leaf switch	<ul style="list-style-type: none"> <li>• It can be installed and removed with the conductivity on.</li> <li>• No mechanism broken.</li> <li>• The installation and removal state is updated at cover open / close.</li> </ul>
	Near full detection	Photo sensor	Stop printing when printing 200 images (average image occupied area 20%) after near full is detected.)
Printhead dust proof filter	Exist / non-exist detection	When it is not installed, the waste toner box cannot be installed.	

Table 2-2. Sensors

Unit	Detection Item	Detection Method	Note
Fusing unit	Exist / non-exist detection	Contact point conductivity check method	
	New / old detection	Fuse method (when new one is installed, it is fused off.)	
	Installation and removal detection at power supply ON	Contact point conductivity check method	<ul style="list-style-type: none"> <li>• It can be installed and removed with the conductivity on.</li> <li>• No mechanism broken.</li> <li>• The installation and removal state is updated at cover open / close.</li> </ul>
	Used amount detection	Measures the driving period (fusing motor rotational period)	Calculated by 30 seconds interval.
	Near end detection	Measures the driving period (fusing motor rotational period)	28880 count
	End detection	Measures the driving period (fusing motor rotational period)	36000 count After end detection, print less than 100 images (300 seconds) and stops after printing.



Table 2-2. Sensors

Unit	Detection Item	Detection Method	Note
ET cartridge	Exist / non-exist detection	Contact point conductivity check method	
	New / old detection	Fuse method (when new one is installed, it is fused off.)	
	Installation and removal detection at power supply ON	Contact point conductivity check method	<ul style="list-style-type: none"> <li>It can be installed and removed with the conductivity on.</li> <li>No mechanism broken.</li> <li>The installation and removal state is updated when the rack rotates one-round at cover open / close.</li> </ul>
	Left amount detection	MCU counts the number of images.	
	Near end detection	<ul style="list-style-type: none"> <li>MCU counts the number of images.</li> <li>Soft count the period of laser diode light emitting time.</li> </ul>	4.8 k images or whichever comes first.
	End detection	<ul style="list-style-type: none"> <li>MCU counts the number of images.</li> <li>Reflective photo sensor.</li> </ul>	6.0 k images or whichever comes first.
	EPSON genuine product detection	Non-compatible rib	Cannot be installed structurally.

Table 2-2. Sensors

Unit	Detection Item	Detection Method	Note
Transfer belt unit	Exist / non-exist detection	Check AIDC sensor GND connection.	
	New / old detection	Fuse method (when new one is installed, it is fused off.)	
	Installation and removal detection at power supply ON	Check AIDC sensor GND connection.	<ul style="list-style-type: none"> <li>It can be installed and removed with the conductivity on.</li> <li>No mechanism broken.</li> <li>The installation and removal state is updated at cover open / close.</li> </ul>
		Contact point conductivity check method	<ul style="list-style-type: none"> <li>It can be installed and removed with the conductivity on.</li> <li>No mechanism broken.</li> <li>The installation and removal state is updated when the rack rotates one-round at cover open / close.</li> </ul>
	Used amount detection	Transportation motor driving time accumulated period	Calculated by 30 seconds interval.
	Near end detection	Transportation motor driving time accumulated period	12000 count
	End detection	Main motor driving time accumulated period	15000 count After end detection, print less than 100 images (300 seconds) and stops after printing.

Table 2-2. Sensors

Unit	Detection Item	Detection Method	Note
Standard tray	No paper detection	Leaf switch	
Standard cassette	Exist/ non-exist detection	Leaf switch	Serves both as paper side detection
	Paper size detection	Leaf switch (working with edge guide)	A4 or letter
	Near end detection	Photo sensor	50 ± 30 sheets (80g/m <sup>2</sup> )
	No paper detection	Leaf switch	
Double side print unit	Exist/ non-exist detection	Short pin detection	Installation and removal at conducted is not assured. Only at powering on, checks installation and removal.

## 2.2 Printing Process

The figure below is the flow of the printing process.

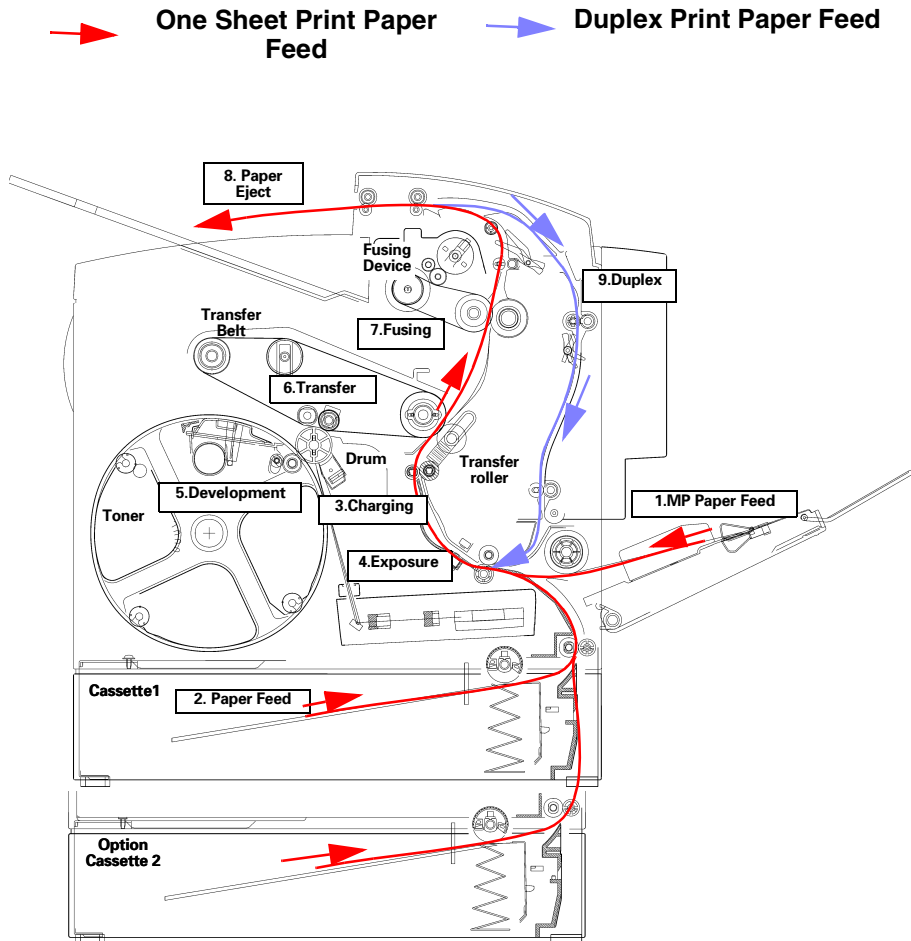

Figure 2-6. Paper Path

Table 2-3. Printing Process

No.	Unit Name	Unit Function
1.	Printing process	Paper feed→ Charging→ Exposure→ Development→ Transfer→ Fusing→ Paper Eject
2.	Paper feed	Loads paper from Tray 1, Tray 2, Tray 3 (option).
3.	Charging	Equally charges (-) to the surface of OPC drum by scotron method
4.	Exposure	The laser emits a laser beam toward the OPC drum surface. A laser beam creates the electrostatic latent image on the drum surface.
		After the mid-transfer, cleaning blade collects toner which did not stick to OPC drum, to the waste toner box.
5.	Development	Provides toner on the electrostatic latent image to create toner image. (Puts toner where exposed by laser beam.)
		Emits light to erase the remaining electric charge (after-image). Light source: LED
6.	Transfer	Primary transfer
		Paper transfer
		Transfer belt cleaning
7.	Suction carrier	Carries image transferred paper smoothly without vibration to the fusing device.
8.	Fusing	Fuses the toner image on paper by the heat and pressure of heat roller + pressure roller.
9.	Paper Eject	Ejects image fused paper to the paper eject tray.

## 2.2.1 Paper Feed Mechanism

EPSON AcuLaser C2000 has 2 paper feed methods:  
Tray 1 (150 sheets) + Tray 2 (500 sheets)

Optional 500 sheets cassette unit (Tray 3) is also available.

### 2.2.1.1 Tray 1

When the paper feed solenoid (SL 8) is turned ON, the driving power from the transfer motor (M1) is transmitted to the paper feed roller via the paper feed clutch (one-way clutch). Paper pushing plate is pushed to the paper feed roller, and the paper feed roller rotates. The printer feeds the top sheet of paper. Paper fed by the paper feed roller is carried to the timing roller via transportation roller.

- Separation pad method is used in order to separate each paper and prevent feeding the second paper together.
- If paper is OHP, it is detected by OHP sensor (PC11).
- Paper empty switch (S9) detects if there is paper on Tray 1.
- Tray 1 position sensor (PC15) detects if Tray 1 is pulled and the paper pushing plate is ready to push paper to the paper feed roller.

Paper Feed Back View

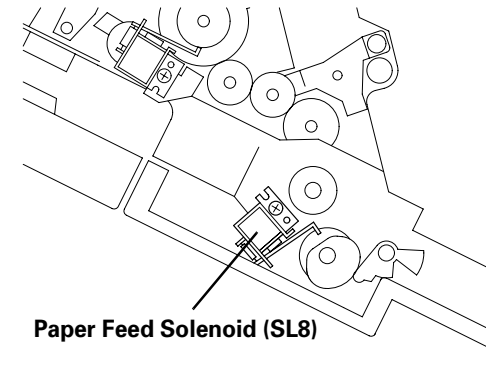

Paper Feed Front View

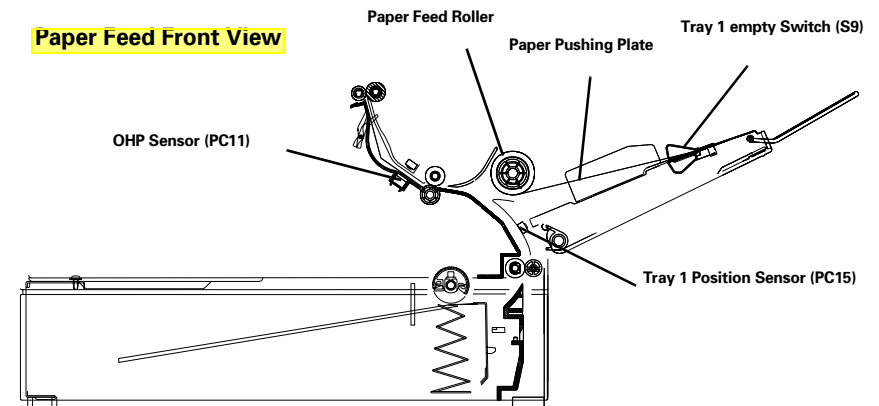

Figure 2-7. Tray 1

### 2.2.1.2 Tray 2 (Cassette 1)

When Tray 2 paper feed solenoid is turned ON, paper feed roller rotates. When paper feed roller rotates, the printer picks the top sheet of paper from Tray 2.

- ❑ Paper empty sensor (PC1) detects if there is paper on Tray 2. Paper near empty sensor (PC2) detects and warns when paper on the cassette becomes less than about 20 sheets.
- ❑ The paper size switch detects if there is paper on Tray 2 and its paper size.

Paper Feed Front View

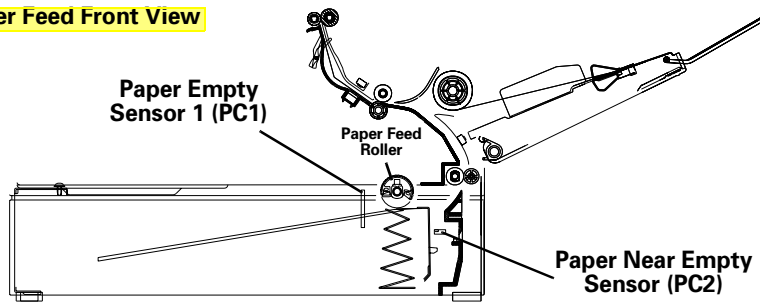

Cassette 1 Front View

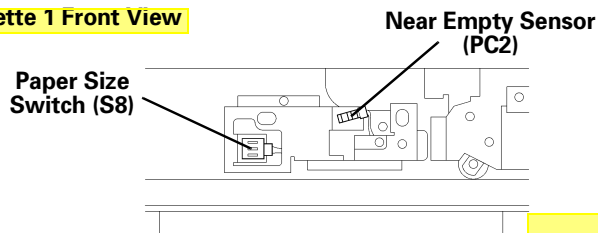

Cassette 1 Right Side View

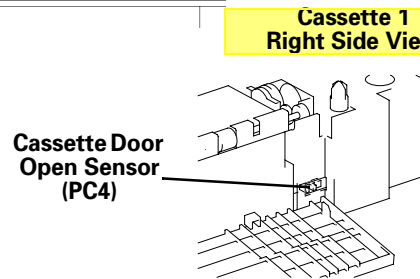

Tray 2 Back View

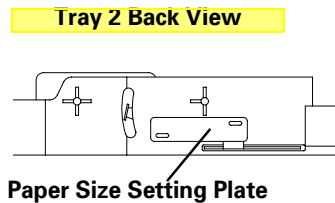

Figure 2-8. Tray 2

### 2.2.1.3 Tray 3 (Cassette 2)

Tray 3 is the optional 500 sheets cassette unit. Tray 3 paper feed jam is detected by a newly added Tray 3 paper feed sensor.

See 2.2.1.2 Tray 2 (Cassette 1) about other structure and functions.

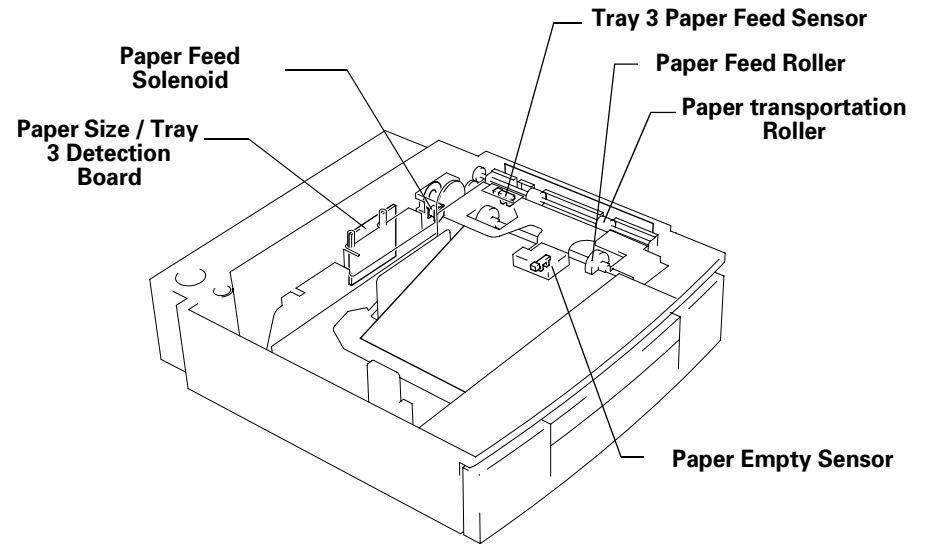

Figure 2-9. Tray 3

### 2.2.1.4 Timing Roller

Timing roller adjusts paper skewing carried by the paper feed mechanism and rotates as the top of image on the transfer belt comes on the end of paper.

- Timing sensor (PC5) detects that the top of paper carried by the paper feed mechanism reaches the timing roller.
- When it detects paper, turns off the intermittent roller solenoid and pauses carrying paper.
- Timing roller starts rotating when a certain amount of time passed after timing roller solenoid (SL5) is ON. If it fails to do so, load paper again to prevent paper load failure (only for color printing).
- When paper is longer than specification or smaller than A5 size, it detects paper size error.

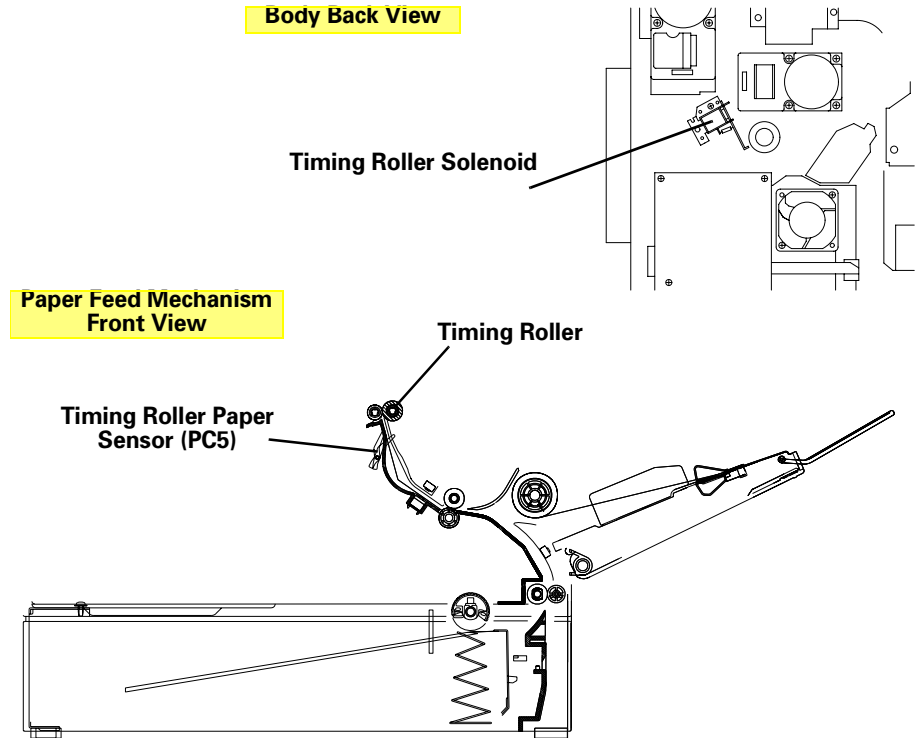

Figure 2-10. Timing Roller

### 2.2.2 Charging Process

Charging is done by giving static electricity on the OPC drum before laser exposure. Scotron method is adopted for electric charger.

- Generated ozone will be eliminated by the filter which is attached at ozone fan.

The figure below is OPC drum cartridge.

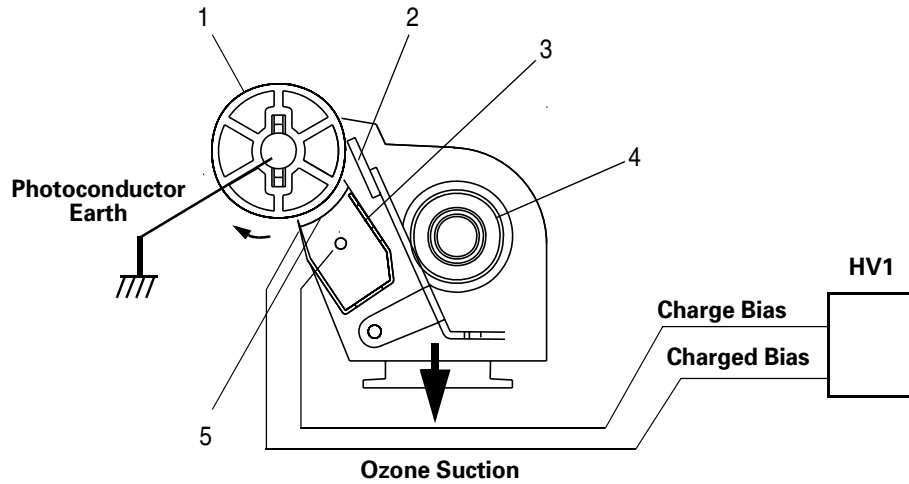

Figure 2-11. Charging Process

**Table 2-4. Charging Process**

No.	Name	Explanation
1	Photoconductor	Creates the latent image by laser beam on the surface of the OPC drum (photoconductor), develops the image by toner, and transfers the image on the transfer belt.
2	Cleaner Blade	Cleans the remaining toner on the photoconductor.
3	Electric Charger	Scotron method charger gives (-) electricity on the photoconductor.
4	Rotation coil	This coil carries waste toner, generated from the photoconductor, to the waste toner bottle.
5	Grid Electrode	Steadily provides electricity, generated by electric discharge, to the photoconductor.

### 2.2.3 Exposure Process

The printer creates the latent image on the photoconductor by the laser beam emitted from the printhead. Printing position is adjusted as described below.

- Main Scanning Printing (Horizontal)
  - By SOS sensor on the laser diode control board (PWB-C), the main scanning printing start position is determined.
- Sub Scanning Printing (Vertical)
  - When it receives PRINT signal from the controller, the engine control board (PWB-A) rotates the polygon motor (M6) and transfer motor.
  - When transfer belt position sensor becomes ON, the printhead receives video signal from the controller and adjust the sub scanning printing start position by emitting the laser beam and starts exposure.

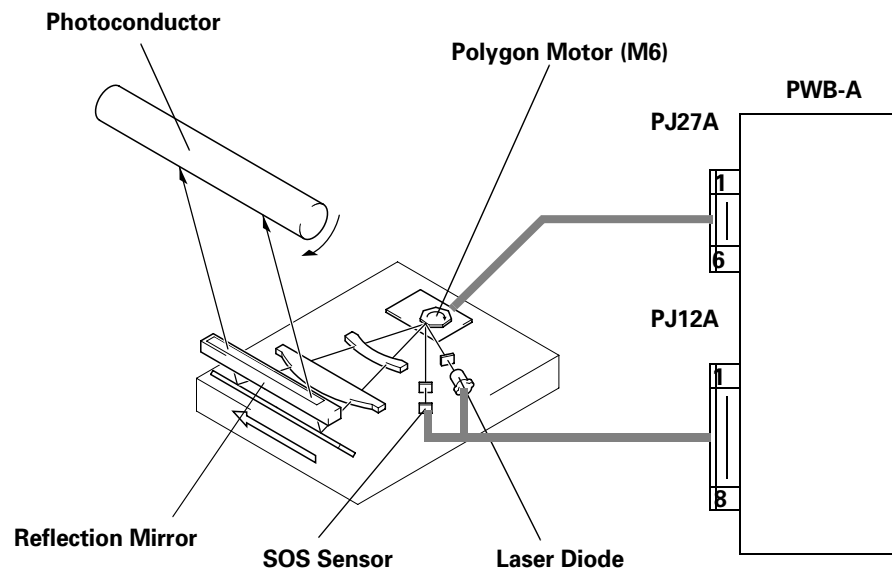

**Figure 2-12. Exposure Process**



## 2.2.4 Development Process

### Color Development Process

The printer proceeds the following creation process for each toner (YMCK) respectively and creates 4 color toner image on the transfer belt. Then, the printer transfers the toner image on the transfer belt onto paper. Full color image is thus generated on the paper.

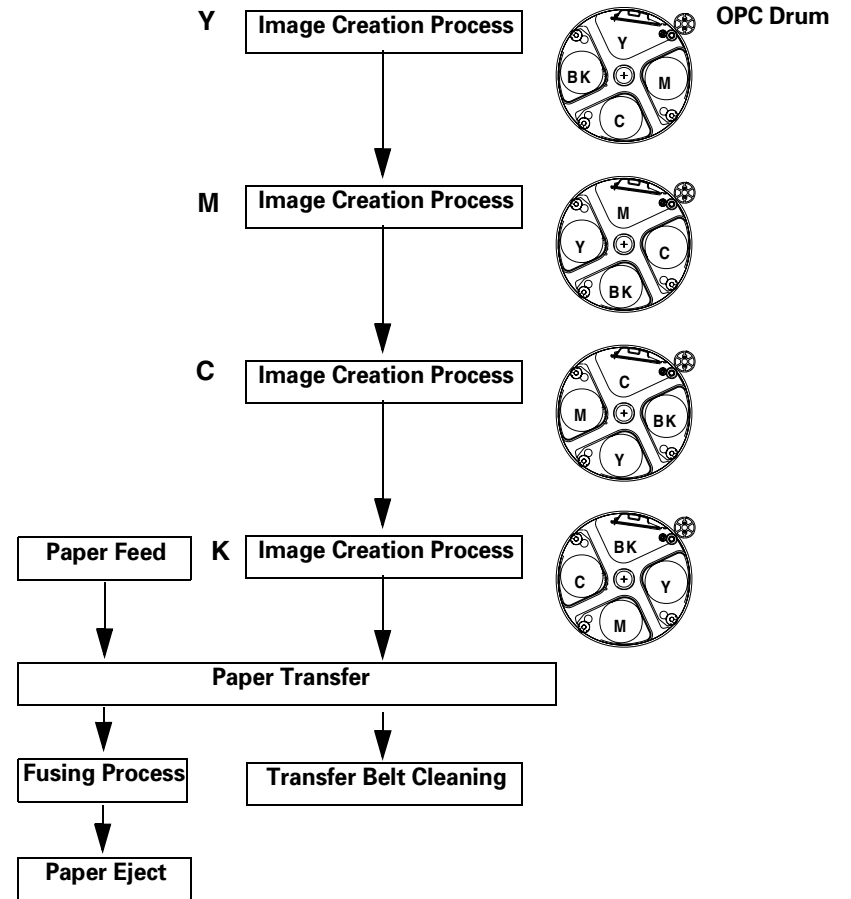

Figure 2-13. Color Development Process

### 2.2.4.1 Toner Cartridge Rack

- Process: Charging→ Exposure→ Pre-erase→ Mid-Transfer→ Photoconductor Cleaning

There are 4 toner cartridges, Yellow, Magenta, Cyan, Black and they are stored in the rotational toner cartridge rack.

For printing, the printer rotates the toner cartridge rack to shift the respective toner cartridge to the developing position in Y, M, C, K order.

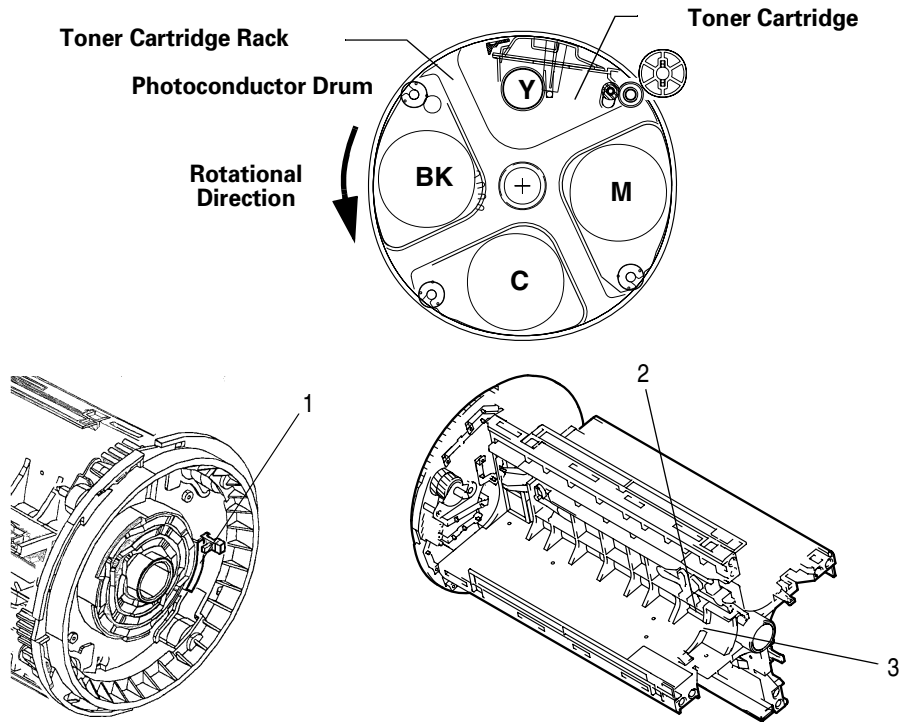

Figure 2-14. Toner Cartridge Rack

Table 2-5. Toner Cartridge Rack

No.	Name	Explanation
1	Rack black position detection sensor and light-proof plate	Sensor and light-proof plate detects that the rack black toner is at the developing position.
2	Toner empty detection sensor window	Toner of the toner cartridge detects empty.
3	Toner color rib	Rib determines the toner color when installing the toner cartridge to the rack.

### Toner Cartridge Developing Position

Each toner cartridge developing position is precisely determined and preserved by the rack motor. Stepping motor is used for rack motor to control the rack rotational angle precisely.

- Black toner starting position
  - Turn on the rack motor and the rack starts free rotation.
  - When the rack black position detection sensor (PC6) is turned on, stops rack motor.
  - Counter-rotate the developing motor.
  - Rotate the developing motor and adjust the rack to the developing position.
- Each color toner starting position
  - Respective YMC toner starting position is precisely determined by controlling the number of rotation.
  - Turn on the rack motor and rotates the rack 90 degree to the next toner.
  - Stops the rack motor.
  - Counter-rotate the developing motor.
  - Regular-rotate the developing motor to adjust the rack to the developing position.

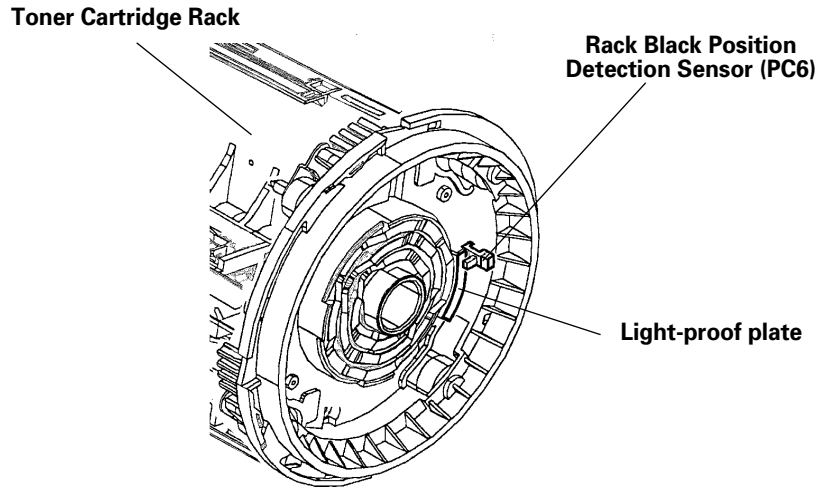

Figure 2-15. Toner Cartridge Developing Position

### 2.2.4.2 Toner Cartridge

Toner cartridge gives toner on the electrostatic latent image on the photoconductor (OPC drum) to create the toner image. (Development)

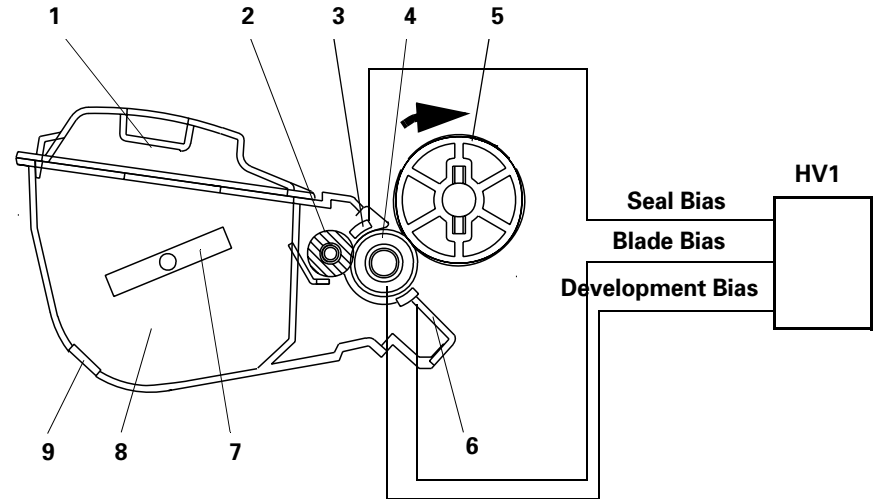

Figure 2-16. Toner Cartridge

Table 2-6. Toner Cartridge

No.	Name	Function
1.	Reflection mirror	Reflects LED light of toner empty detection.
2.	Toner transportation roller	Carries toner to the sleeve roller.
3.	Bias seal	Collects toner that did not stick to the OPC drum.
4.	Development roller	Gives toner to the OPC drum and develops electrostatic latent image.
5.	Photoconductor	Electrostatic latent image is created by the laser exposure, developed by the resin sleeve, and the developed toner image is carried to the surface of the transfer belt.

Table 2-6. Toner Cartridge

No.	Name	Function
6.	Toner regulation plate	Put the toner thin and equal upon the development roller (rubber). Charges toner (-) electricity by letting toner through between toner regulation plate and developing roller.
7.	Toner agitation wing	Agitates the toner hopper inside and sends toner to the toner sending roller.
8.	Toner hopper	Toner is in.
9.	LED percolation window	LED light for toner empty detection goes through this window.

**Development**

Toner regulation plate puts toner thin and equal upon the sleeve roller, gives toner on the electrostatic latent image on the OPC drum, and develops toner image on the photoconductor.

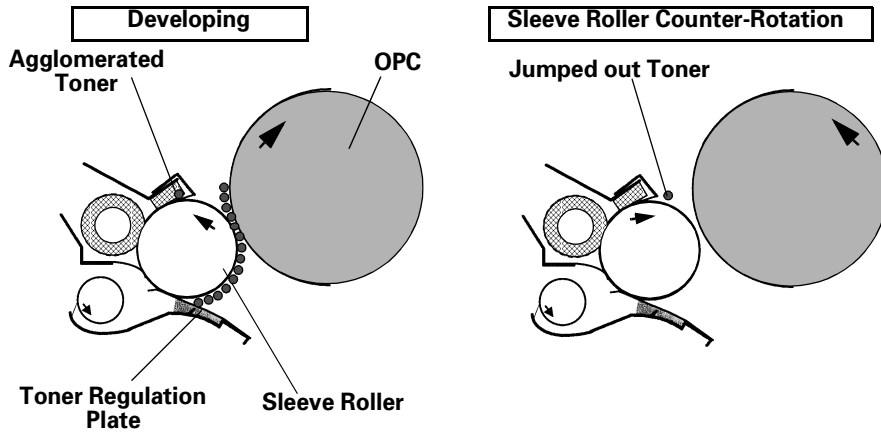

**Figure 2-17. Development**

**Toner Empty Detection**

Toner empty detection is done by the following procedure.

The light from the toner empty detection LED (LED1) on the toner empty detection board (PWB-H) is reflected by the reflection mirror inside the toner cartridge. Photo sensor (PT1) measures this reflected light and detects the toner empty by the largeness and length of the reflected light.

Toner empty is detected by the above mentioned optical detection or the value of image counter whichever comes first.

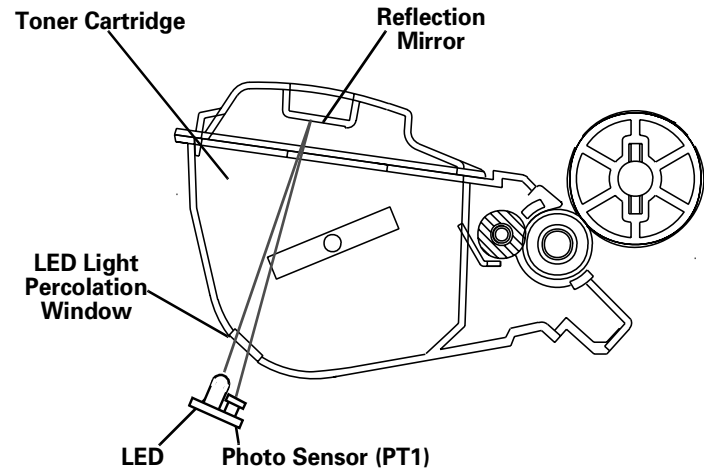

**Figure 2-18. Toner Empty Detection**

**Table 2-7. Remaining Toner**

Detection	K Toner	Color (Y, M, C) Toner
Toner Empty	50 ± 20g	50 ± 20g

**Toner Near Empty Detection**

Toner near empty is detected by the image dot counter (Integrated value of Video Data integrated per line) or the image counter whichever comes first.

### 2.2.4.3 Names of Unit Contacting Terminals

#### 1. Drum Cartridge Terminals

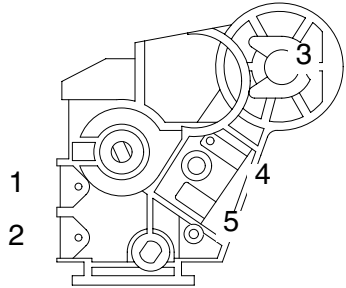

1	New Fuse
2	(2: Dual purpose, detection of D/C)
3	Earth
4	Electrification Bias
5	Charge Bias

#### 2. Toner Cartridge Terminals

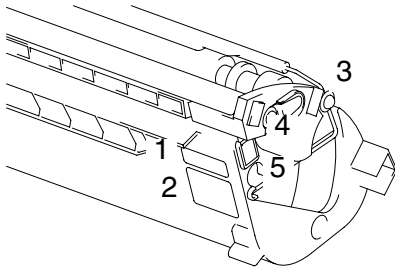

1	New Fuse
2	(2: Dual purpose, detection of T/C)
3	Regulation Bias
4	Collecting Plate Bias
5	Development Bias

#### 3. Toner Rack Terminals

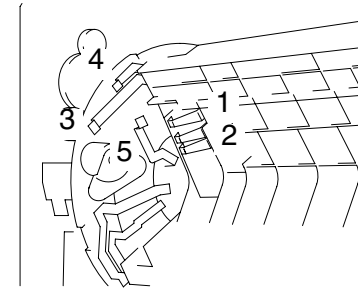

1	New Fuse
2	(2: Dual purpose, detection of T/C)
3	Regulation Bias
4	Seal Bias
5	Development Bias

#### 4. Transfer Belt Unit Terminals

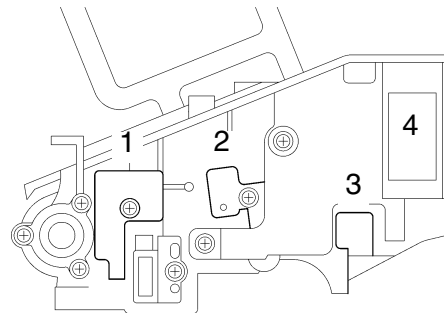

1	Secondary Transfer Bias
2	Primary Transfer Bias
3	Earth
4	Drawer Connector

#### □ OC (oil coating) Roller Terminals

1	New Fuse
2	
3	Serves both as OC exist detection

## 2.2.5 Transfer Process

Transfer is done twice: mid-transfer and paper transfer.

### 2.2.5.1 Mid-Transfer Belt Unit

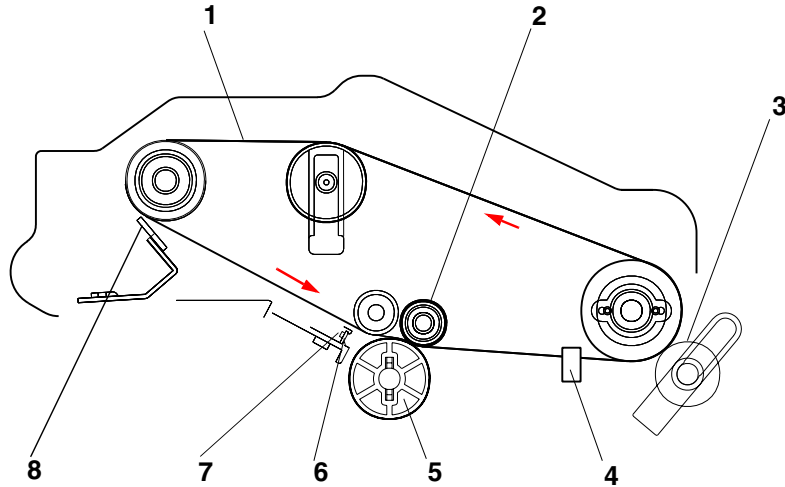

Figure 2-19. Mid-Transfer Belt Unit

Table 2-8. Mid-Transfer Belt Unit

No.	Name	Explanation
1	Transfer Belt	Transfers each toner image on the OPC drum to the surface of the belt in Y, M, C, K order in piles.
2	Electrode Roller	Transfers the toner image on the OPC drum to the transfer belt.
3	Transfer Roller	Transfers the toner image to the transfer belt to paper.
4	Transfer Belt Position Sensor (PC12)	Detects the image transferring start timing by the timing of transfer belt moving.
5	Photoconductor	Creates toner image

Table 2-8. Mid-Transfer Belt Unit

No.	Name	Explanation
6	Eraser Lamp	Erases electricity on the OPC drum where toner is not on before mid-transfer.
7	AIDC Sensor	Detects the drum cartridge with or without. Measures the density of the AIDC mark which is generated on the OPC drum by toner.
8	Cleaning Blade	Scratches off the waste toner remaining on the transfer belt after paper transfer.

### 2.2.5.2 Mid-Transfer

Mid-transfer method is belt transfer method.

It transfers the toner image on the OPC drum which is made by the color development process, to the transfer belt in the order of Yellow, Magenta, Cyan, Black in piles.

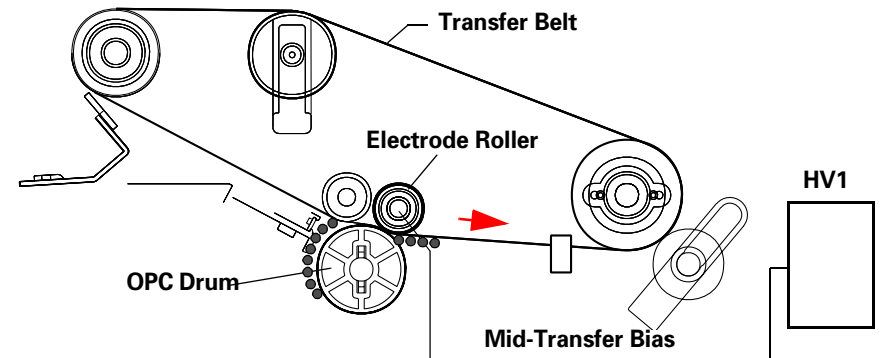

Figure 2-20. Mid-Transfer

### 2.2.5.3 Paper Transfer

Paper transfer method is roller transfer method.

Transfers the toner image on the transfer belt to the paper by the transfer roller.

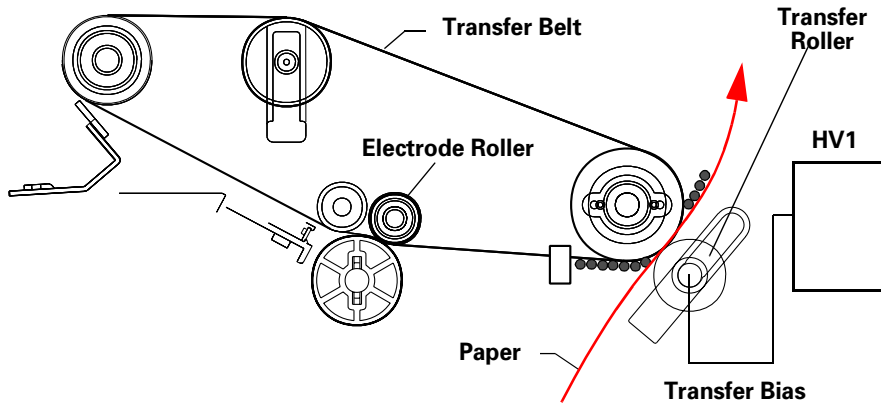

Figure 2-21. Paper Transfer

### Transfer Roller Pressed / Estranged

Transfer roller is pressed or estranged to the transfer belt according to its necessity.

- Transfer roller pressure solenoid is turned ON and the driving force from the carrier motor is transmitted to the cam via clutch, then the cam rotates. Transfer roller is pressed to the transfer belt as shown in the figure below (right).
- Transfer roller pressure sensor is turned OFF and detects the transfer roller pressed.
- When the transfer roller pressure solenoid is turned ON again and the cam rotates, the transfer roller is estranged from the transfer roller as shown in the figure below (left).

Transfer Roller Estranged

Transfer Belt Pressed

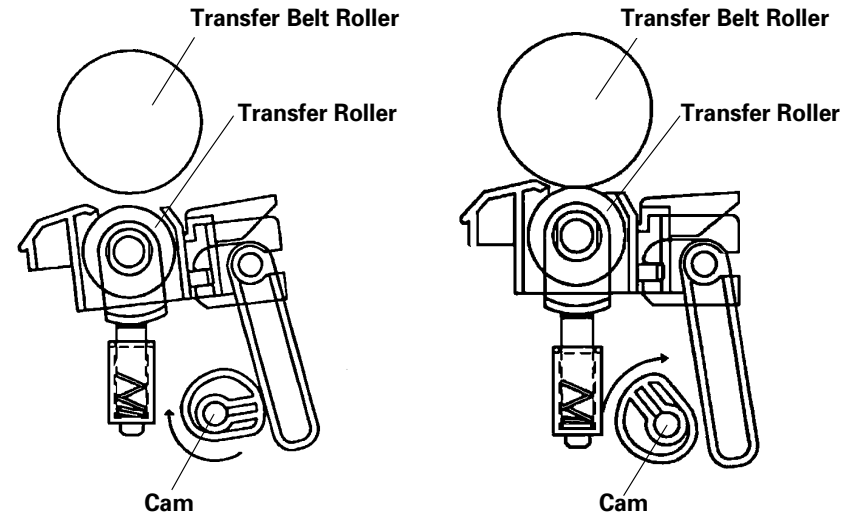

Figure 2-22. Transfer Roller Pressed / Estranged



---

## Pre-Transfer Erase

---

Pre-transfer erase eliminates the electricity where no toner is on.

24 eraser lamp (LED) is located in one line on the AIDC/Eraser Board. They light the surface of the OPC drum after development.

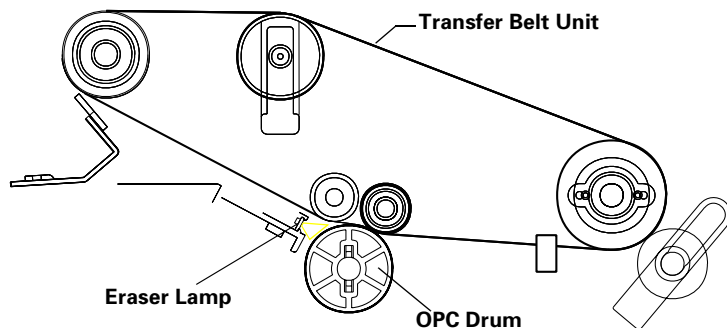

**Figure 2-23. Pre-Transfer Erase**

---

## Humidity Sensor

---

Humidity sensor (HS1) rear bottom of the mechanism measures the humidity and temperature of the outside of the mechanism. CPU reads this data and determine the transfer bias.

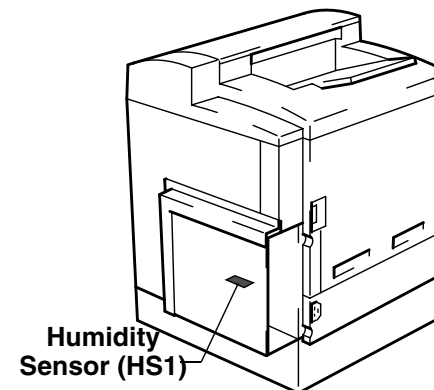

**Figure 2-24. Humidity Sensor**

---

## AIDC (Automatic Image Density Control)

---

AIDC detects AIDC mark density made on the OPC drum by AIDC sensor that is located at the same position with eraser lamp and determines the appropriate development bias at printing.

- AIDC density detection is performed by a set of LED and 2 photo sensors.
- AIDC detection is made for respective toner cartridge when powering the switch on or during the pre-rotation when opening or closing the front top right cover.

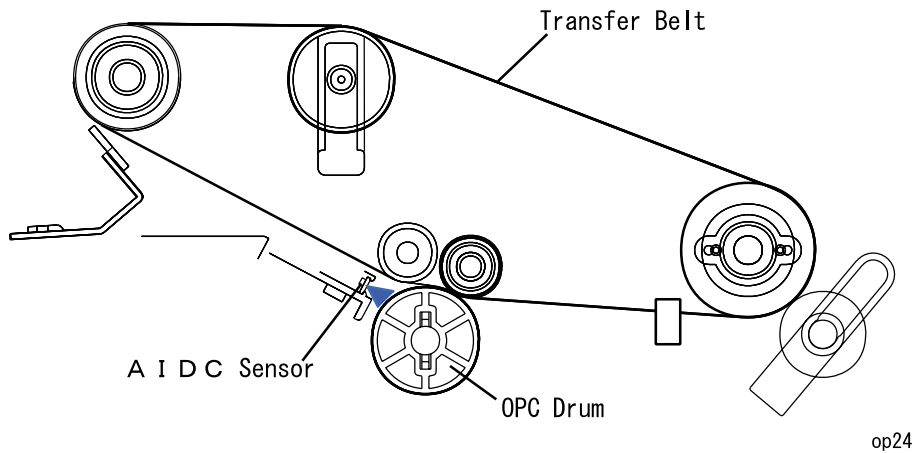

Figure 2-25. AIDC

### Transfer Belt Cleaner Estrangement

Transfer belt cleaner is pressed or estranged to the transfer belt according to its necessity.

- Transfer belt cleaner turns cleaner motor ON, rotates cam to rotate the lever holder, and pushes the (↓) part in Figure 2-26 down and estrange the transfer belt cleaner from the transfer belt.
- Belt cleaner estrangement position sensor is turned OFF and detects the estrangement of the transfer belt cleaner.
- Turns the cleaner motor ON and rotates the cam to loosen the lever holder, and then presses the transfer belt cleaner to the transfer belt.
- Pressure is added since the paper transfer is done until the belt goes around.

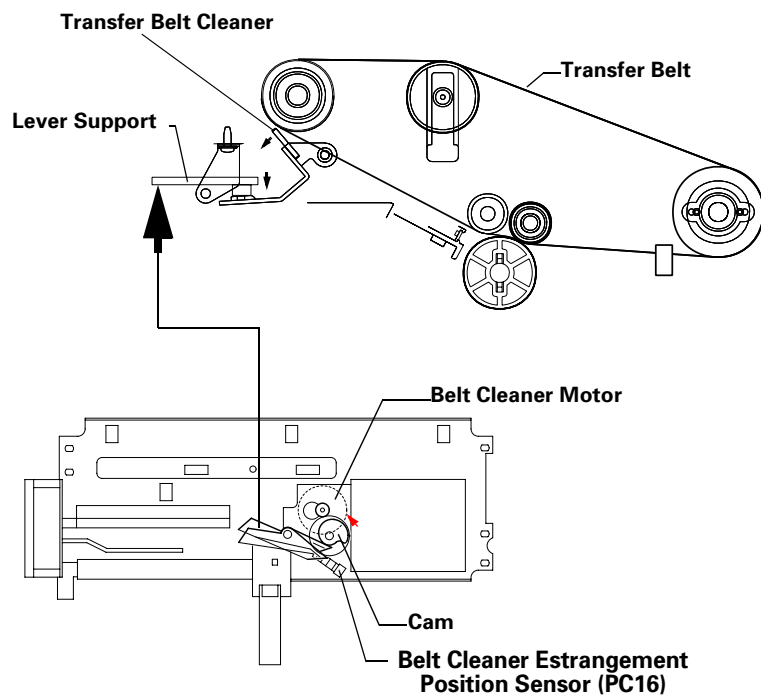

Figure 2-26. Transfer Belt Cleaner Estrangement

## 2.2.6 Waste Toner Bottle

Waste toner bottle collects waste toner on the transfer belt and the waste toner on the OPC drum.

After the printer transferring the toner image on the transfer belt to paper, the transfer belt cleaner scratches off the waste toner on the transfer belt and the waste toner collecting coil carries waste toner to the waste toner bottle.

After the printer mid-transferring the toner image on the OPC drum, the cleaner blade scratches off the waste toner remaining on the OPC drum and the waste toner collecting coil carries waste toner to the waste toner bottle.

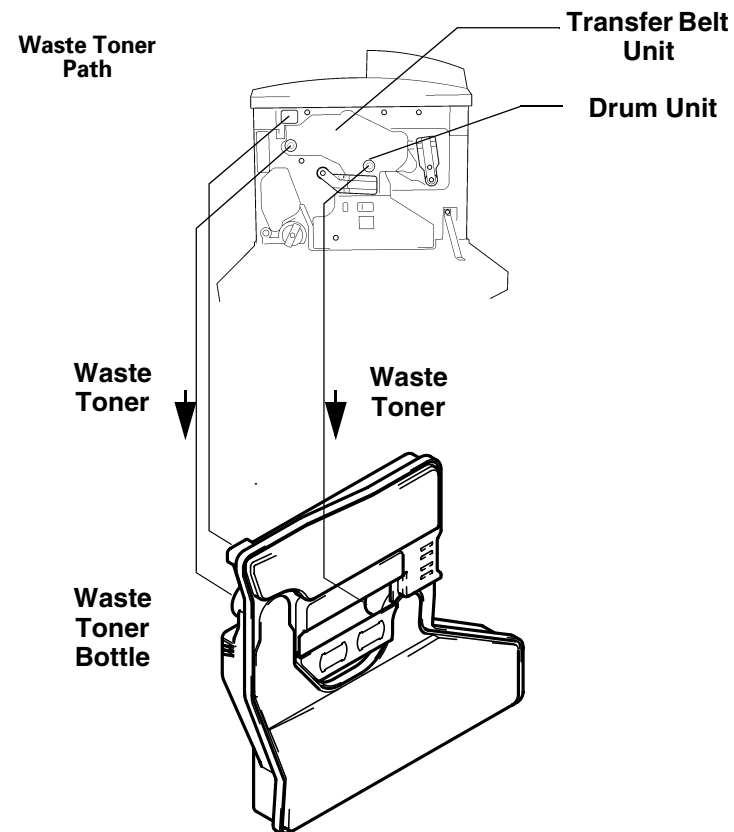

Figure 2-27. Waste Toner Bottle

---

### Waste Toner Bottle Detection

---

Waste toner bottle P/H filter switch (S10) detects if the waste toner bottle is with or without.

---

### Waste Toner Full Detection

---

Waste toner full sensor (PC13) detects if the waste toner bottle is full of waste toner or not.

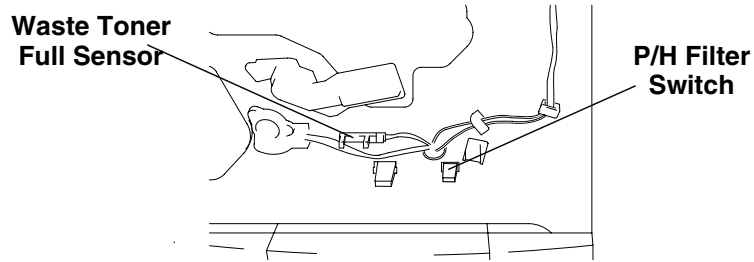

**When waste toner is low.**

Sensor LED light percolates the bottle and reaches the photo sensor.

**When toner full is detected.**

When waste toner comes to the point of toner full detection, LED light of the sensor is blocked off by the waste toner and the sensor detects toner full.

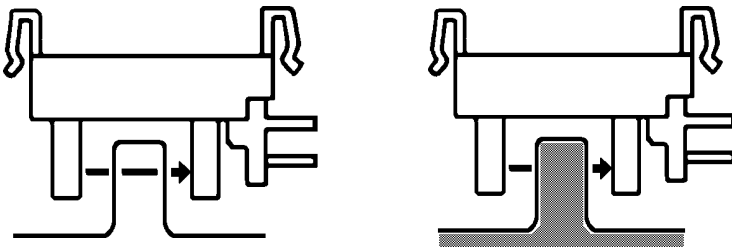

Figure 2-28. Waste Toner Full Detection

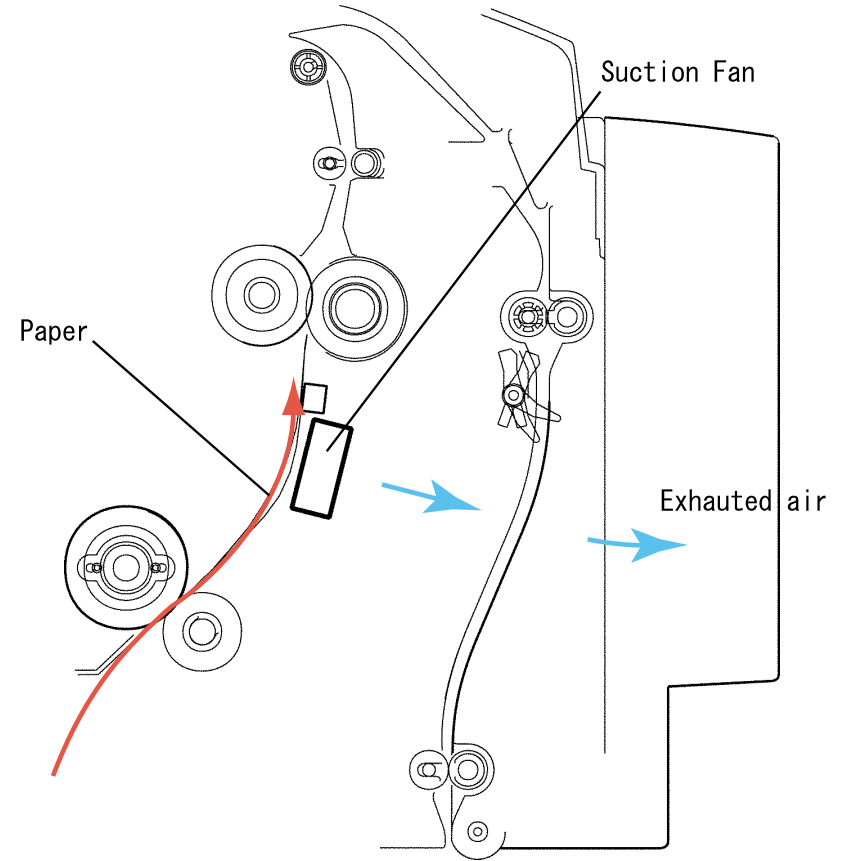

Figure 2-29. Suction Transportation

op28

**2.2.7 Suction Process**

Transferred paper is sucked to the carriage path by the suction fan motor (M7) and carried to the fusing device stably.

- Carriage path is short and there is no special device like suction belt.
- The exhaustion of the suction fan is emitted outside through Tray 1 or Duplex unit.

**2.2.8 Fusing Process**

**2.2.8.1 Fusing Unit**

Fusing method is belt heat fusing method. Belt heat fusing method fuses the toner image to the paper by the heat of the fusing belt heated by the heater lamp, and fuses toner by the pressure between the fusing roller and pressure roller.

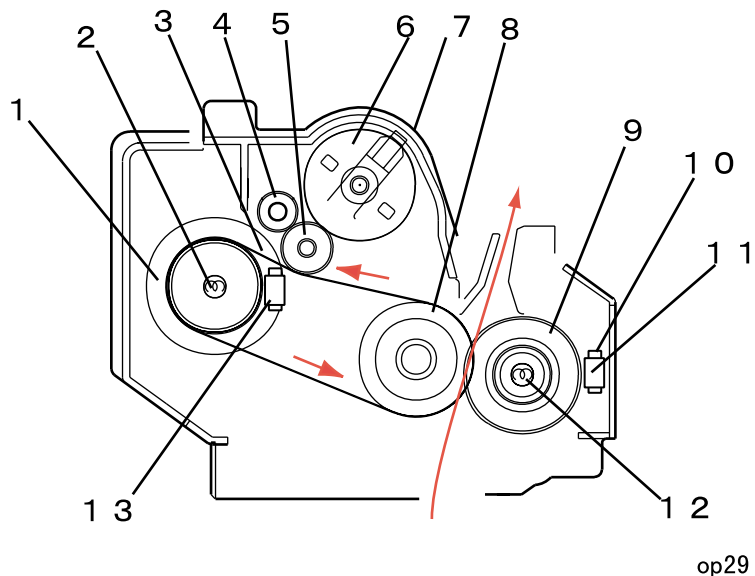

Figure 2-30. Fusing Unit

Table 2-9. Fusing Unit

No.	Name	Explanation
9	Pressure Roller	Uses rubber roller and applies pressure to paper by pressure spring.
10	Thermistor (TH2)	Detects the surface temperature of the pressure roller.
11	Thermostat (TS2)	When temperature of the pressure roller becomes abnormally high, this thermostat is cut off and turns off the heater lamp.
12	Heater Lamp (H2)	Heats the pressure roller by the heat of heater lamp (600W).
13	Thermistor 1 / Thermostat	Detects the surface temperature of the heat roller. When the sensor detects abnormal high temperature, the thermostat 1 is cut off and turns the heater lamp off.

Table 2-9. Fusing Unit

No.	Name	Explanation
1	Heat Roller	Transmits heat of the heater lamp to the fusing unit.
2	Heater Lamp (H1)	Heats the heat roller by the heat of heater lamp (600W).
3	Fusing Belt	Provides the heat of the heat roller to the fusing roller and paper.
4	Cleaning Roller	Cleans the applying roller.
5	Applying Roller	Applies oil by cleaning the fusing belt.
6	Oil Supplying Roller	Contains oil and supplies oil to the applying roller.
7	Oil Applying Roller Unit	Applies oil to the fusing belt as needed.
8	Fusing Roller	Fuses toner on the fusing belt and paper to paper.

### 2.2.8.2 Fusing Temperature Control

#### Control Circuit

Thermistor 1 (TH1) detects the surface temperature of the heat roller and inputs temperature signal to CPU. Heater lamp (H1) turns on/off according to the heater on/off signal, which is conveyed in the form of Pout signal output according to the thermistor 1 detected temperature.

- The surface temperature of the pressure roller is adjusted by the heater lamp (H2) and thermistor 2.
- Even when the thermistor detects the abnormal high temperature (the surface temperature of the roller exceeded 210°C), if the Pout signal is not turned OFF, the printer turns off the relay of PU1 and turns the heater lamp OFF compulsory.

Table 1-1. Heater Lamp On/OFF Signal

L	Heater ON
H	Heater OFF

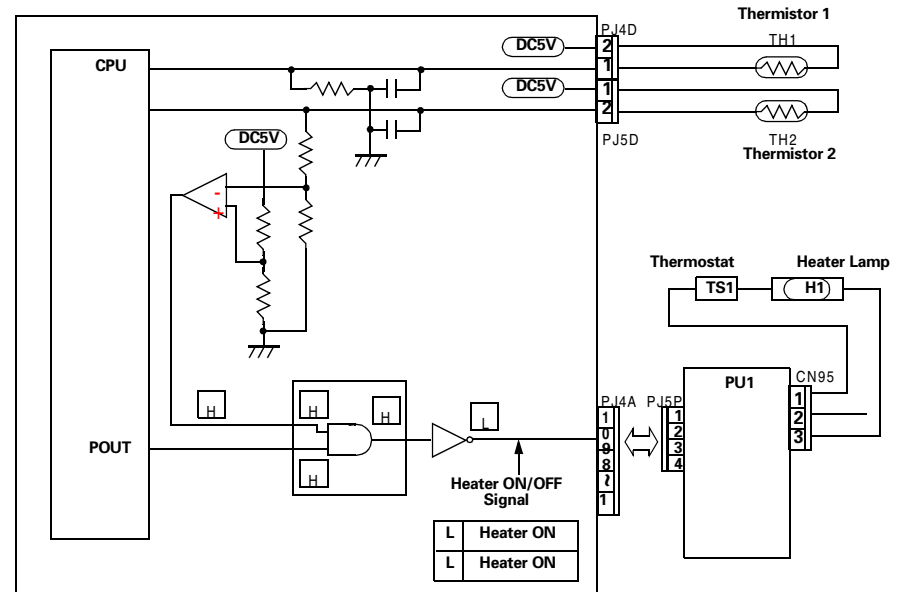
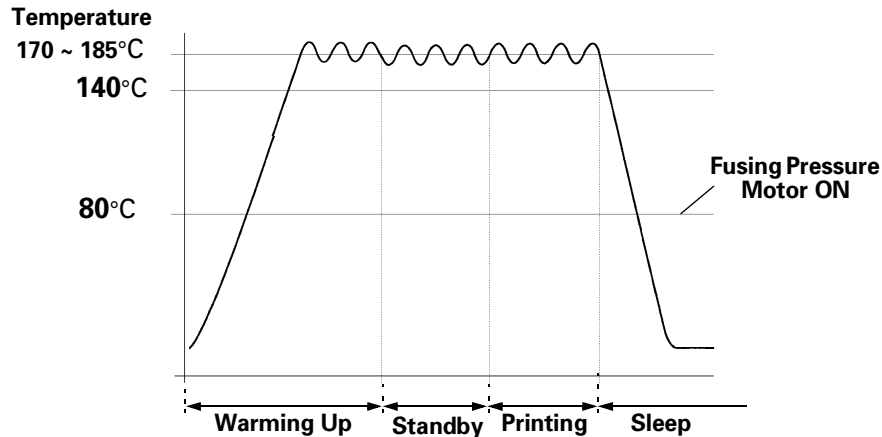

Figure 2-31. Fusing Temperature Control

**Temperature Control**

When heating the roller, the temperature control drives the fusion motor and fuses the pressure roller. It is estranged on the envelope mode.



**Figure 2-32. Temperature Control**

**Table 2-10. Temperature Control**

No.	Timing	Temperature Control																		
1	Warm up	When turning the power switch ON, warming up is started and the heater lamp is turned ON. After the pressure roller is heated, pressure is started and the fusion motor is turned ON. Fusion motor is kept to be ON until the temperature of the heat roller becomes 170°C and the pressure roller becomes 140°C. Then the fusion motor is turned OFF to estrange the roller.																		
2	Stand-by	Controls the temperature of the heat roller to be 170°C.																		
3	Printing	CPU reads the exo-mechanical sensor (HS1) and heat roller temperature (TH1) and controls the heat roller temperature as shown below. Note: Heat roller temperature is controlled a little low.																		
		<table border="1"> <thead> <tr> <th>Paper Type</th> <th>Monochrome</th> <th>Color</th> </tr> </thead> <tbody> <tr> <td>Plain Paper</td> <td>175°C ~ 185°C</td> <td>170°C ~ 180°C</td> </tr> <tr> <td>Thick Paper</td> <td>165°C ~ 175°C</td> <td>160°C ~ 175°C</td> </tr> <tr> <td>OHP</td> <td>155°C ~ 160°C</td> <td>155°C ~ 160°C</td> </tr> <tr> <td>Letter Head</td> <td>175°C ~ 185°C</td> <td>170°C ~ 180°C</td> </tr> <tr> <td>Envelope</td> <td>175°C ~ 180°C</td> <td>175°C ~ 180°C</td> </tr> </tbody> </table>	Paper Type	Monochrome	Color	Plain Paper	175°C ~ 185°C	170°C ~ 180°C	Thick Paper	165°C ~ 175°C	160°C ~ 175°C	OHP	155°C ~ 160°C	155°C ~ 160°C	Letter Head	175°C ~ 185°C	170°C ~ 180°C	Envelope	175°C ~ 180°C	175°C ~ 180°C
		Paper Type	Monochrome	Color																
		Plain Paper	175°C ~ 185°C	170°C ~ 180°C																
		Thick Paper	165°C ~ 175°C	160°C ~ 175°C																
		OHP	155°C ~ 160°C	155°C ~ 160°C																
Letter Head	175°C ~ 185°C	170°C ~ 180°C																		
Envelope	175°C ~ 180°C	175°C ~ 180°C																		
4	Sleeping	When it received sleep mode signal from the controller, the printer turns off the heater lamp. It keeps heater lamp OFF condition until it receives the releasing command from the controller. If the printer receives the sleep mode command amid printing, the printer controls sleep after printing.																		

## Fusing Speed Switching Control

The printer switches the rotational speed of the carrier motor and fusion motor according to the paper type. See the table below.

**Table 2-11. Fusing Speed Control**

Paper Type	Monochrome	Color
Plain Paper	160mm/sec	160mm/sec
Thick Paper	60mm/sec	60mm/sec
OHP	60mm/sec	60mm/sec
Envelope, Label, Post Card	60mm/sec	60mm/sec

### Operational Principles of the Fusing Speed Switching Function

1. At the mid-transfer, BK toner transfer on the transfer belt has completed.
2. The printer switches the speed of the carrier motor (M1) and fusion motor (M4) from 160mm/sec to 60mm/sec.
3. Transfer belt rotates once.
4. Timing roller rotates.
5. Paper transfer is started.
6. Paper passes the paper eject sensor (PC8).
7. The printer switches the speed of the carrier motor (M1) and fusion motor (M4) from 60mm/sec to 160mm/sec.

**CAUTION**



The speed of fusion motor is fine-tuned according to the final caliber of the roller. Never touch the built-in resistance (VR1D).

- Fusing Roller Pressured / Estranged
  - The pressure roller of the fuser is applied to the fusing roller as needed.
  - Pressured
    - When the fusing pressure motor turns on and rotates the pressure, it rotates the sectored gear, pull the pressure roller and pressure the pressure roller to the fusing roller.
    - Fusing pressure position sensor (PC10) turns on and detects the pressure of the pressure roller.
    - Turns off the fusing pressure motor.
  - Estrangement
    - The fusing pressure motor counter rotates on and loosen the pressure gear to estrange the pressure roller.
    - Pressure roller estrangement sensor supervises the pressure roller estrangement and keeps it estranged for the specified period.
    - Turns off the fusing pressure motor.

**NOTE:** It is estranged at envelop mode.

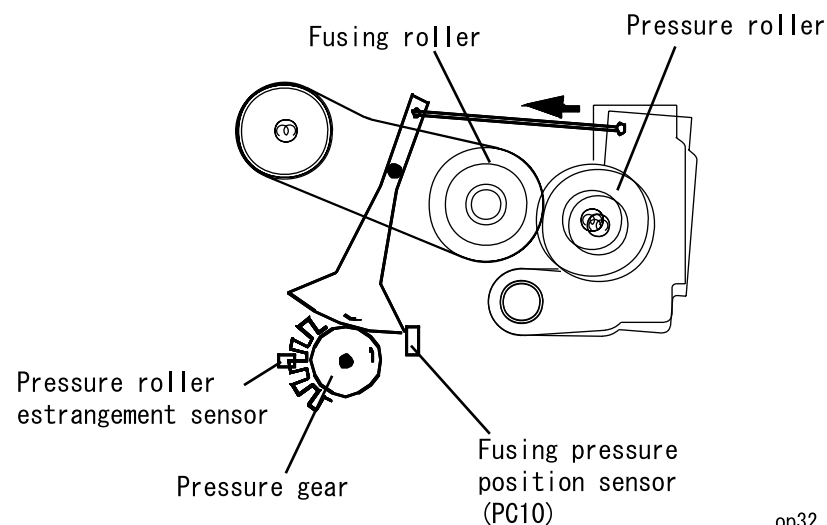

op32

**Figure 2-33. Fusing Roller Pressured / Estranged Detection**



### 2.2.8.3 Fusing Oil Roll

The function of the fusing oil roll is as follows.

- It prevents the toner on the paper before the fusing phase from attaching to the roller.
- Clean the fusing roller surface.
- For color page printer (ex. this product), it makes the copy surface shining like the photographs.

### 2.2.9 Paper Eject Process

Remove electricity from the image fused paper and eject paper to the paper eject tray.

- Paper eject sensor (PC8) detects paper eject.
- When Duplex unit is installed, the Duplex unit switch back motor controls the paper eject roller.

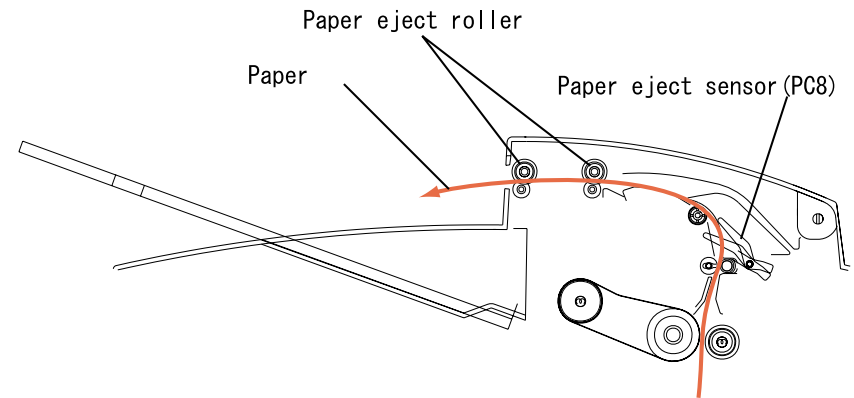

op33

Figure 2-34. Paper Eject Process

### 2.2.9.1 Duplex Unit (option)

The figure below shows the paper path when the duplex unit is installed. When the duplex is installed, the paper eject roller is driven by switch back motor and the paper transportation roller is driven by fusing motor. When printing on the back side, the paper eject roller counter-rotates and feeds paper to the duplex unit.

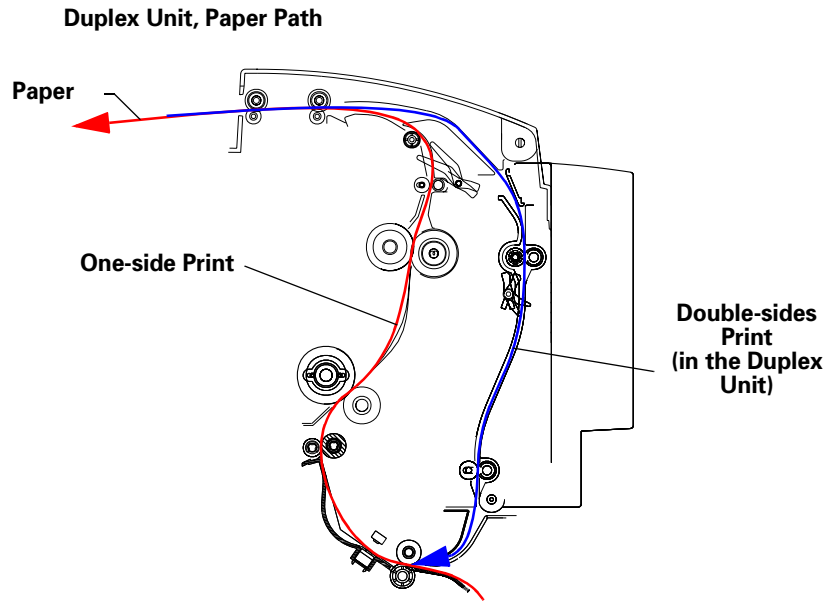

Figure 2-35. Paper Eject

□ Duplex paper load method

■ 2 sheets inside circulation method

When printing A4 / letter paper, print the front of 1st and 2nd page, the back of 1st and 2nd page, print the front of 1st and 3rd page and so on.

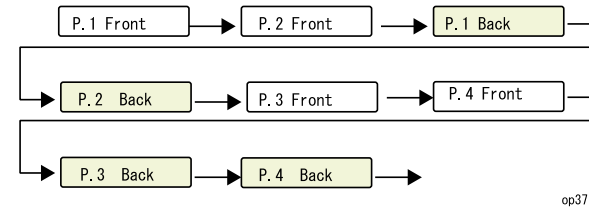

Figure 2-36. 2 Sheet Inside Circulation

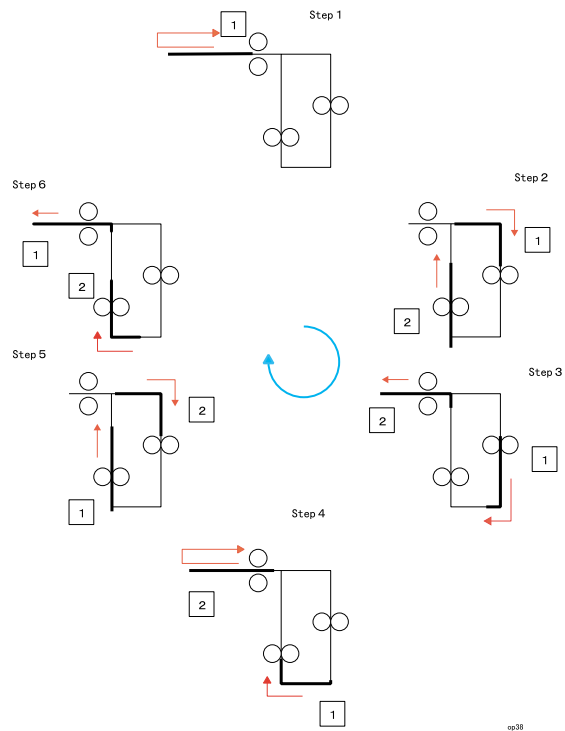

Figure 2-37. 2 Sheets Inside Circulation -- Double-side Printing

## 2.3 Controller Board (C314MAIN) Operating Principles

The following is the C314MAIN board block diagram.

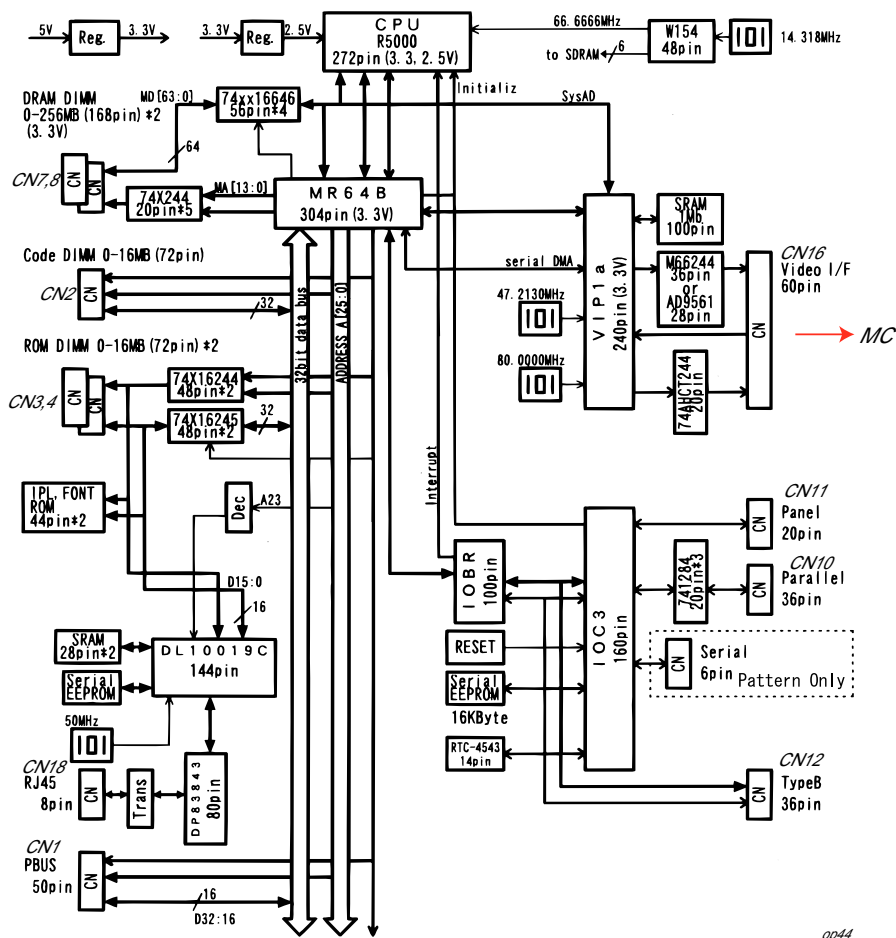

Figure 2-38. C314MAIN Board Block Diagram

### 2.3.1 Specification

Table 2-12. Specification

Item	Location	Note
CPU	IC1	266MHz (outside clock 66.6666MHz) R5000A
E05B51BB	IC2	<ul style="list-style-type: none"> <li>ASIC MR64</li> </ul> Connected to CPU and controls access to the memory and peripheral devices.
E05B52AA	IC4	<ul style="list-style-type: none"> <li>ASIC TORB</li> </ul> Connects MR64 and IOC3.
E05B40BA	IC5	<ul style="list-style-type: none"> <li>ASIC IOC3</li> </ul> Interface I/C - Panel - Timer - Parallel I/F, Type-B I/F
E05B79BA	IC6	<ul style="list-style-type: none"> <li>New video ASIC VLP1a</li> </ul> - Color laser printer video I/F - Engine I/F - Improve the half tone gradation - Color conversion - Zip / unzip function
RAM DIMM	S0	JEDEC compliance, 32MB, 64bits, 168pin, SPD
RAM DIMM	S1	RAM expansion slot
CODE DIMM	CN2 (Slot0)	<ul style="list-style-type: none"> <li>Program ROM</li> </ul> Board assembly, memory, C269PROG
ROM DIMM	CN3, CN4	<ul style="list-style-type: none"> <li>Expansion font</li> <li>EPGL program</li> </ul>
IPL/FONT ROM	IC15, 16	44 pin SOP package
25128	IC21	Serial EEPROM - Stores printer setting
DL10019C	IC	Network control IC
PBUS	CN1	(for HDD connection)
M51953	IC3	<ul style="list-style-type: none"> <li>RESET IC</li> </ul> Reset this controller.
NM93CS56N	IC26	Serial EEPROM - Network controller initialization setting - Stores MAC address - Stores hardware revision

**CHAPTER**

**3**

**TROUBLESHOOTING**

### 3.1 Troubleshooting Method

It is difficult to specify the cause of the trouble for the page printer has the complex mechanical structure. This chapter describes the method to specify the trouble cause from the error symptoms and how to solve the problem.

#### 3.1.1 Troubleshooting Procedure

To find cause of the trouble, you have to follow the service manual and check the printer and the information gathered from the customer. This should be done step by step. Read the repair procedure in the table below.

Remove any parts or unit that are not the genuine products of EPSON.



**Be careful to draw the paper feed tray when the paper feed roller is at the middle of the pick up position to avoid breaking part.**

**Table 3-1. Preparing Procedure**

Procedure	Solution / Explanation
1. Before starting troubleshooting	Understand what problems user have.
2. Power ON setting position	1. When turning the printer ON, does initialization and engine self-check perform all right? 2. Is there any problem at the setting place?
3. Panel indication	Does the panel indicate "Ready" or the energy-saving mode? 1. Insert the panel connector properly. 2. Perform the paper feed test (engine test) of the self-check function. Refer to 3.1.3 "Self Check Function" 3. After confirming the panel indication is all right, start solving the error.

**Table 3-1. Preparing Procedure**

Procedure	Solution / Explanation
4. Image quality problem	Is the print out image quality meet the customers' expectation? 1. Compare the output image with the image on the printed setting information page. 2. If the output is all white, replace the toner cartridge or pull up the contacting point of the toner cartridge for better contact. 3. If the output is all black, pull up the contacting point of the toner cartridge for better contact.

**Table 3-2. Initial Check Point**

Item	Symptom / Cause	Solution
1. Turning the power ON.	1. Engine does not start at all.	<ul style="list-style-type: none"> <li>• Check if the power supply cable is inserted to the printer and plug.</li> <li>• Check if the power supply voltage is all right.</li> </ul>
	2. Engine cooling fan does not rotate. (Does not rotate when turning the power ON.)	Replace the fuse of the engine power board.
2. Power supply environment.	Power supply voltage is not within $\pm 10\%$ of the one described on the manufacture label.	Use the plug that meets the specification.

Table 3-2. Initial Check Point

Item	Symptom / Cause	Solution
3. Setting environment	1. The place has vibration and inclination.	Place the printer even and stable place that is not subject to vibration.
	2. Temperature and Humidity is not within the specification described in Ch1.	Set the printer where there is no fire nearby and no direct air-conditioning wind.
	3. The setting place is subject to the direct sunlight.	Advise the customer to avoid the direct sunlight using curtain.
	4. The setting place is dusty.	Avoid dusty place to set the printer.
	5. The ammonia gas is generated from diazo copy or floor detergent nearby.	Remove the printer from the ammonia gas.
4. Paper size	The paper type and size is not correct.	Advise the customer to use paper which meets the printer specification.

Table 3-2. Initial Check Point

Item	Symptom / Cause	Solution
5. Maintenance	The maintenance is not performed properly.	Clean the paper path. Replace the roller if the surface is noticeably dirty.
	The fusing belt is dirty.	Replace the oil coating roller.
6. Caution in the winter	When setting the printer that is cooled down by the fresh air into the warm room, condensation may be generated inside and may result in the following symptoms. <ul style="list-style-type: none"> <li>• Lens is steamed up and the image is too weak.</li> <li>• Because of charging failure, the image is too strong.</li> <li>• Because paper is wet, paper is corrugated.</li> <li>• Fusing becomes irregular.</li> </ul>	Turn the printer ON and leave the printer for about 20 minutes. Open the drum and toner cartridge after warming them up with the room temperature.

### 3.1.2 Power is not Applied

**Table 3-3. Power is not applied**

	Check Item	→	Solution
1	Is the power switch ON?	No	Turn the power ON.
2	Is the power cable connected to the printer properly?	No	Connect the power cable to the printer properly.
3	Is the power cable connected to the plug properly?	No	Connect the power cable to the plug properly.
4	Is the connector on the power board inserted correctly?	No	Insert the connectors correctly.
5	Is the fuse on PU1 (power board) blew out?	Yes	Replace the fuse.
		No	Replace the PU1 (power board).

### 3.1.3 Self Check Function

The printer has the following mode for self-check function.

- Test print  
Check the trouble if it is the controller side error or the engine side error.

---

#### Procedure

---

1. Turn the printer OFF.
2. Remove the controller.
3. Remove the jammed paper.
4. Insert the paper on either Tray 1, Tray 2 or Tray 3.
5. Turn the printer ON.
6. Engine feeds a sheet in the priority order of option cassette, paper load cassette, manual tray. If the optional double unit is installed, it also operates.



- If an error is occurred at the option, the printer does not feed paper.
- It takes about 1 minute to complete the paper feed from the test start.

7. If the printer can perform printing normally, you can conclude that there is no error on the engine side except the controller and interface error. The printing pattern is shown below.



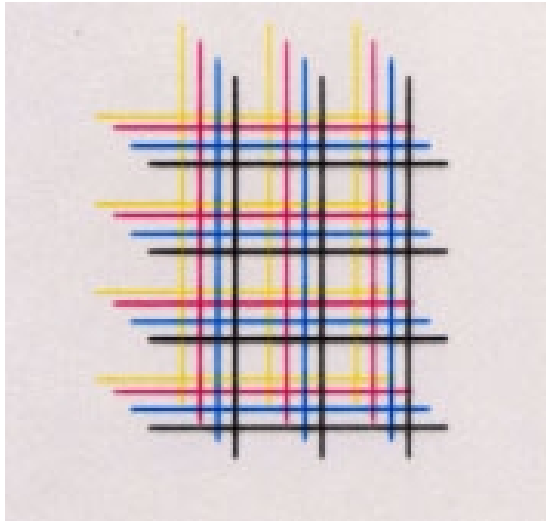

Figure 3-1. Print Pattern

## 3.2 Printer Message

The message of this printer is categorized into the following 4 types.

- Status**  
Indicates the printer status.  
Status message is indicated only when no error occurred or during the initialization.
- Error**  
Indicates the error status.
- Warning**  
Indicates the warning status. Print job is not halted.
- Service call error**  
Indicates errors that requires service call.

### 3.2.0.1 Messages

A list of this printer's printer message is shown below. Each message is the message when "Lang = English" is set.

As for warning messages, by pressing the Continue switch, the lower order warning messages are displayed in their order.

If the LED message is new for this product, it marked as new at the right end column.

See the following tables for the list of this printer's printer message.

**Table 1-2. List of Printer Messages**

LED Message	Category	Status code
(Display when Power is Turned On)	Status	
Service Req Cffff	Service Call Error	6000
Service Req Efff	Service Call Error *1	6001 - 6999
ROM CHECK	Status	
RAM CHECK	Status	
HDD CHECK	Status	
Self Test	Status	
Reset All	Status	1004
Reset	Status	1004
Check Duplex P-Size	Error	4016
Check Media Type	Error	4226
Jam x x x x (x=A,B,C1,C2,DM)	Error*2	4008,4009,4017,4012
uuuu Toner Crtg Out (uuuu=CMYK, only the relevant item is displayed.)	Error	4049 - 4063
Install Photocondctr	Error	4022

Table 1-2. List of Printer Messages

LED Message	Category	Status code
Install Waste T Box	Error	4023
Install Fuser	Error	4221
Install Oil Roll	Error	4024
Install TransferBelt	Error	4222
Clean Sensor	Error	4228
uuuu Toner Out (uuuu = CMYK, only the relevant item is displayed.)	Error	4065 - 4079
Replace Photocondctr	Error	4028
Replace Waste T Box	Error	4029
Replace Fuser	Error	4223
Replace Oil Roll	Error	4030
Replace Transfer Belt	Error	4224
Printer Open	Error	4002
Cover C1 Open	Error	4037
Cover C2 Open	Error	4037
Manual Feed sss ttt (sss: see *3, ttt:see *4)	Error	1013
Can't Print Duplex	Error	3005
Paper Out sss ttt (sss: see *3, ttt:see *5)	Error	4010
Paper Set sss ttt (sss: see *3, ttt:see *5)	Error	3003
Print Overrun	Error	3000
Mem Overflow	Error	3001
Duplex Mem Overflow	Error	3004

Table 1-2. List of Printer Messages

LED Message	Category	Status code
Invalid HDD	Error	4202
Invalid PS3	Error	4201
Invalid AUX I/F Card	Error	4014
Invalid ROM A	Error	4003
Invalid ROM B	Error	4003
Write Error ROM A	Error	4006
Write Error ROM P	Error	4006
Reset to Save	Status	
Writing ROM A	Status	1005
Writing ROM P	Status	1005
Menus Locked (Panel Setting Display)	Warning	
PS3 Hard Disk full	Warning	2561
Collate was Disabled	Warning	2013
Check Paper Size	Warning	2004
Image Optimum	Warning	2002
Check Paper Type	Warning	2008
Need Memory	Warning	2003
Format Error ROM A	Warning	2000
Format Error ROM B	Warning	2000
Form Feed	Status	1008
(Displayed during test printing)		1010
Warming Up	Status	1006
Calibrating Printer	Status	1014
Cooling Down	Status	1016

Table 1-2. List of Printer Messages

LED Message	Category	Status code
Offline	Status	1001
Job Cancel	Status	
uuuu Toner Low (uuuu = CMYK, only the relevant item is displayed.)	Warning	2017 - 2031
Worn Photocondctr	Warning	2010
Waste T Box Nearfull	Warning	2011
Worn Fuser	Warning	2562
Oil Roll Near Empty	Warning	2012
Worn Transfer Belt	Warning	2563
Standby	Status	1007
Ready	Status	1000

\*1: See 6.5 Service Call Error Messages.

\*2: In some cases a Jam occurs at several places at once. In such a case, maximum 4 places can be displayed and their priority order in display and EJM is A->B->C1->C->2->DM. The names of the Jam locations are separated by a single space.

Jam locations and corresponding status are as follows;

- 1) 4012: A
- 2) 4008: B
- 3) 4009: C1, C2
- 4) 4017: DM

\*3: Of the Values for Paper Source in the panel setting, the relevant values, except for Auto, are displayed.

\*4: Of the Values for Page Size in the panel setting, the relevant values are displayed.

\*5: Of the Values for each paper feed size in the Tray Menu in the panel setting item, the relevant values are displayed.

### 3.2.1 Printer Message Details of Status Messages and Remedies

Below are the status messages that are unique to this printer.

#### Calibrating Printer

- **Explanation**  
This is one READY message. At the following timing, engine is automatically calibrated.

1. At powering on
2. Cover is opened and closed except for canceling Jam error.
3. It has printed 100 pages or 24 hours passed from the last calibrating and returned from Standby state.

- **LED**  
The Continue LED is off. LED blinks.

- **Treatment Method**  
Wait for about one minute and the printer will automatically resume. Do not open any printer cover while calibrating.

#### Cooling Down

Now cooling down the printer engine.

- **Explanation**  
At the following timing, cooling operation is automatically started. When starts print to OHP sheets, if the internal temperature is too high.

- **LED**  
The Continue LED is off. LED blinks.

- **Treatment Method**  
Wait for about one minute and the printer will automatically resume and start printing.

### 3.2.2 Details of Error Messages and Remedies

Below are the error messages that are unique to this printer.

#### Check Media Type

- **Explanation**  
A paper which is not correct OHP sheet is fed. Or printed on OHP sheets although OHP has not been selected. Does not print and eject the sheet. When duplex is selected, sheet remains in the Duplex unit and paper jam occurs.

- **LED**  
The On Line LED is off and Continue LED is on.

- **Treatment Method**
  - 1) Set correct sheet to the paper feeder.  
Press the Continue switch to release the error.
  - 2) Execute Reset or Warmboot.

#### Install Photoconductor

- **Explanation**  
The Photoconductor Unit is not set. Or it is not set correctly.

- **LED**  
The On Line LED and Continue LED are off.

- **Treatment Method**  
Open the Front cover. Remove the Waste Toner Collector if it is set then reinstall the Photoconductor unit correctly. Reset the Waste Toner Collector then close the Front cover, and the error will be released automatically.

#### Install Waste Toner Box

- **Explanation**  
A Waste Toner Collector is not set. Or it is not set correctly.

- **LED**  
The On Line LED and Continue LED are off.

- **Treatment Method**  
Open the Front cover, set a Waste Toner Collector, then close the cover. The error will be canceled automatically.

#### Install Oil Roll

- Explanation  
The Fuser Oil Roll is not set. Or it is not set correctly.
  - LED  
The On Line LED and Continue LED are off.
  - Treatment Method  
Open the cover-A, set a Fuser Oil Roll, then close the cover-A. The error will be canceled automatically.
- Install Fuser
- Explanation  
The Fuser unit is not set. Or it is not set correctly.
  - LED  
The On Line LED and Continue LED are off.
  - Treatment Method  
Open the cover-A, remove the Fuser Oil Roll if it is set. Set a Fuser unit, then set the Fuser Oil Roll again. Close the cover-A and the error will be canceled automatically.
- Install TransferBelt
- Explanation  
The Transfer Belt unit is not set.
  - LED  
The On Line LED and Continue LED are off.
  - Treatment Method  
Open the Front cover, remove the Waste Toner Collector and the Photoconductor Unit if they are set. Set a Transfer Belt Unit and reset the Photoconductor Unit and the Waste Toner Collector. Close the Front cover and the error will be canceled automatically.
- Clean Sensor
- Explanation  
The window of sensor for engine calibration is soiled.
  - LED  
The On Line LED and Continue LED are off.
  - Treatment Method  
Open Front Cover and remove Waste Toner Collector. Turn the green lever (at left side o the center) upward then put it back. Reinstall Waste Toner Collector then close Front Cover.
- uuuu Toner Out
- Explanation  
It is detected that there is no toner remaining by the toner end sensor for each color. If it is canceled temporarily by pressing the Continue switch, this error will be produced in every page printed. When Toner Out = Continue, this error is not produced. u u u u indicates C, M, Y, K toner cartridge, which correspond to the C, M, Y and K toner cartridges, and out of these, those toner cartridges only where it is detected that there is no toner remaining are displayed.
  - LED  
The On Line LED is off and Continue LED is on.  
(This specification is different from that of AcuLaser C8500.)
  - Treatment Method
    - 1) Replace toner Cartridge.  
Open the Front cover, replace empty toner cartridge with new one.  
Close all covers and the error will be canceled automatically.  
Toner Counter is reset automatically.
    - 2) Press the Continue switch to cancel the error temporarily.

- Replace Photoconductor
  - Explanation  
It is regarded that the photoconductor service life is end, based on the total number of revolution of the photoconductor up to now from previous replacement. And printing is stopped.
  - LED  
The On Line LED and Continue LED are off.
  - Treatment Method  
Open the Front Cover and replace Waste Toner Collector, Photoconductor Unit and Print Head Filter with new ones.  
Close the Front cover and the error will be canceled automatically. The photoconductor counter is reset automatically and the panel display "Photoconductor" in Setup Menu becomes 100%.
- Replace Waste T Box
  - Explanation  
The waste toner box has been sensed to be full of waste toner from the engine, and printing is stopped.
  - LED  
The On Line LED and Continue LED are off.
  - Treatment Method  
Open the Front cover, then replace the Waste Toner Collector with new one. Close the Front cover. The error will be canceled automatically.
- Replace Fuser
  - Explanation  
It is regarded that the Fuser Unit service life is end, based on the total number of revolution of the Fuser Unit up to now from previous replacement. And printing is stopped.
  - LED  
The On Line LED and Continue LED are off.
  - Treatment Method  
Open the Cover-A and remove the Fuser Oil Roll, then replace the Fuser Unit with new one. Reset the Fuser Oil Roll. Then open the Cover-B and replace the 2nd Transfer Roll.
- Replace Oil Roll
  - Explanation  
End of Fuser Oil Roll life. The remaining life is counted in the engine.
  - LED  
The On Line LED and Continue LED are off.
  - Treatment Method  
Open Cover A and replace Fuser Oil Roll with new one. Close Cover A then the error will be cancelled automatically. Remaining of Fuser Oil Roll returns 100%.
- Replace Transfer Belt
  - Explanation  
It is regarded that the Transfer Belt Unit service life is end, based on the total number of revolution of the Transfer Belt up to now from previous replacement. And printing is stopped.
  - LED  
The On Line LED and Continue LED are off.
  - Treatment Method  
Open the Front cover. Then remove the Photoconductor Unit and replace the Transfer Belt Unit with new one. Then reset Photoconductor Unit. Close the Front cover, then the error will be canceled automatically.
- Printer Open
  - Explanation  
Front cover, Cover-A, Cover-B or Cover DM is/are open.
  - LED  
The On Line LED and Continue LED are off.
  - Treatment Method  
Close all cover and the error will be canceled automatically.

### 3.2.3 Details of Warning Messages and Remedies

This section provides the details of warning messages and remedies that are specific to this printer.

#### □ uuuu Toner Low

##### ■ Explanation

This notifies the user of the warning message that the remaining toner of each color (Y, M, C, K) is low. The remaining toner value for each color is calculated from the engine's remaining toner sensor (actually, the dispensing time), and this message is displayed with the remaining toner is approximately 80%. u u u u indicates CMYK, which correspond to the C, M, Y and K toner cartridges, and out of these, the toner cartridges only where it is detected that the remaining toner is low are displayed.

##### ■ Treatment Method

Display of this message is canceled by any one of the following.

- 1) Press the Continue switch.
- 2) Reset the printer.
- 3) Replace the Toner Cartridge indicated by the message with a new one.

#### □ Worn Photoconductor

##### ■ Explanation

This is a warning message that informs the user that the Photoconductor Unit has almost reached the end of its service life. Photoconductor in the Setup Menu becomes less than 20%.

##### ■ Treatment Method

Use of the photoconductor unit is possible until the "Replace Photocondctr" error is displayed, but basically, it is better to replace it right away. Display of this message is canceled by any one of the following.

- 1) Press the Continue switch.
- 2) Reset the printer.
- 3) Replace the Photoconductor Unit with a new one. At the same time, Fuser Oil Roll, Waste Toner Collector and Print Head Filter should be replaced.

#### □ Waste T Box Nearfull

##### ■ Explanation

This warning message notifies the user that the Waste Toner Collector is nearly full. The Waste Toner When Collector full state is detected, this warning is produced.

##### ■ Treatment Method

Basically, it is better to replace it right away. Or exchanging Photoconductor Kit will also do. Display of this message is canceled by any one of the following.

- 1) Press the Continue switch.
- 2) Reset the printer.
- 3) Replace the Waste Toner Collector with a new one.



Worn Fuser Explanation

This is a warning message that informs the user that the Fuser Unit has almost reached the end of its service life.

 Treatment Method

Use of the Fuser unit is possible until the "Replace Fuser" error is displayed, but basically, it is better to replace it right away. Display of this message is canceled by any one of the following.

1. Press the Continue switch.
2. Reset the printer.
3. Replace the Fuser Unit with a new one. At the same time, 2nd Transfer Roll should be replaced.

 Oil Roll Near Empty Warning is issued when Fuser Oil Roll remaining becomes 20%. The engine counts Fuser Oil Roll remaining. Remedy:

Use of the Oil Roll is possible until the "Replace Oil Roll" error is displayed, but basically, it is better to replace it right away. Display of this message is canceled by any one of the following.

1. Press the Continue switch.
2. Reset the printer.
3. Replace the Fuser Oil Roll with a new one.

 Worn Transfer Belt Explanation

This is a warning message that informs the user that the Transfer Belt has almost reached the end of its service life.

 Treatment Method

Use of the Transfer Belt is possible until the "Replace TransferBelt" error is displayed, but basically, it is better to replace it right away. Display of this message is canceled by any one of the following.

1. Press the Continue switch.
2. Reset the printer.
3. Replace the Transfer Belt Unit with a new one.

### 3.2.4 Service Call Error Messages

There are two types of service call errors; engine related and controller related ones, as shown in the following sections.

#### 3.2.4.1 Engine Related Service Call Error Messages

**Table 3-4. Engine Related Service Call Error Messages**

Error Category e	Error Code fff	Explanation
E	004	(2-4) Engine board malfunction
E	008	(2-8) Main motor malfunction
E	009	(2-9) Fuser motor malfunction
E	011	(2-11) Transfer Belt fan malfunction
E	012	(2-12) Power supply cooling fan malfunction
E	013	(2-13) Inside cooling fan malfunction
E	014	(2-14) Suction fan malfunction
E	015	(2-15) Fuser fan malfunction
E	016	(2-16) Polygon motor malfunction
E	018	(2-18) Laser malfunction
E	020	(2-20) 2nd transfer roller retraction malfunction
E	022	(2-22) Transfer Belt rotation malfunction
E	023	(2-23) Toner cartridge rack malfunction
E	024	(2-24) Heater roller heating malfunction
E	025	(2-25) Heater roller low temperature malfunction
E	026	(2-26) Heater roller high temperature malfunction
E	027	(2-27) Heater roller thermistor malfunction
E	028	(2-28) Pressure roller heating malfunction

**Table 3-4. Engine Related Service Call Error Messages (continued)**

Error Category e	Error Code fff	Explanation
E	029	(2-29) Pressure roller low temperature malfunction
E	030	(2-30) Pressure roller high temperature malfunction
E	031	(2-31) Heater roller thermistor malfunction
E	032	(2-32) Fuser roller retraction malfunction
E	033	(2-33) OHP detection sensor malfunction
E	034	(2-34) Multiple manual feeder pusher malfunction
E	041	(2-41) Main unit memory counter malfunction
E	042	(2-42) Main unit memory data malfunction
E	043	(2-43) Main unit memory access malfunction
E	044	(2-44) Main unit memory installation incorrectness
E	998	Engine communication error

### 3.2.4.2 Engine Related Service Call Error Troubleshooting

#### Fusing Unit is Abnormal

**Table 3-5. Fusing Unit is Abnormal**

No.	Check Item		Solution
1	Check the connection between the fusing unit and connector.	-	Remove the fusing unit and install it again.
2	Does heater lamp 1 (H1) light on when turning the printer on?	No	Replace the fusing unit.
3	Does heater lamp 2 (H2) light on when turning the printer on?	No	Replace the fusing unit.
Others			Replace PU1 (power board). Replace PWB-A.

The abnormal fusing unit is caused by abnormal heat roller temperature up, abnormal heat roller low temperature, abnormal heat roller high temperature, abnormal heat roller thermistor, abnormal pressure roller temperature up, abnormal pressure roller low temperature, abnormal temperature high temperature, abnormal pressure roller thermistor.

1. When the temperature of the heat roller does not go up by the specified value for 22 to 40 seconds after warm-up is started. Same can be said for the pressure roller temperature.
2. When the temperature of the pressure roller does not reach 80°C for 90 seconds after warm-up. It is detected as abnormal pressure roller heat up.
3. When the temperature of the heat roller does not reach does not reach 170°C within 140 seconds after the temperature of pressure roller reaches 80°C after warm-boots, it detects as abnormal heat roller temperature up.

4. When the temperature of the pressure roller does not reach 130°C within 70 seconds after the temperature of the heat roller becomes more than 170°C AND when the temperature of the pressure roller does not reach 150°C within 140 seconds, it detects as the abnormal pressure roller temperature up.
5. During printing or stand-by state, when the temperature of the heat roller goes below 70°C, it detects as abnormal heat roller low temperature. Pressure roller temperature is detected as abnormal pressure roller low temperature.
6. When the temperature of the heat roller goes above 210°C during the temperature control, it detects as abnormal heat roller high temperature. Pressure roller is detected as abnormal pressure roller high temperature.
7. For heat roller, the hard shuts down at 220°C and the thermostat shuts down at 210°C. Pressure roller hard shuts down at 205°C and thermostat shuts down at 150°C.

**Power Supply Cooling Fan Motor is Abnormal**

Abnormal fan motor is detected when any of the following 5 abnormality is occurred; power supply cooling fan motor, mechanism cooling fan motor, suction fan motor, transfer belt fan motor and fusing fan motor.

- Power Supply Cooling Fan Motor is abnormal

**Table 3-6. Power Supply Cooling Fan Motor is Abnormal**

No.	Check Item		Solution
1	At the power ON initialization sequence, does the power supply fan motor (M8) rotate? Check the rotation by its sound or by hand feeling the wind.	No	Remove connector PJ16A and insert it again. Replace the power supply fan motor.
Others			Replace PWB-A.

Power supply fan motor (M8) rotates by two rotational speed; full speed / half speed.

When the power supply fan lock signal becomes active for 0.5 seconds, the printer detects that power supply fan motor is abnormal.

**Table 3-7. Operation of Power Supply Cooling Fan Motor**

	Mechanical Condition	Operation of Fan Motor
1	When the front / fusing cover / transportation cover is opened.	Half speed
2	When the power supply fan motor is abnormal.	Stop
3	When any error occurred during printing. (except when the power supply fan motor is abnormal.)	Full speed for 15 seconds and then half speed
4	When any error occurred during non-printing. (except when the power supply fan motor is abnormal.)	Half speed

**Table 3-7. Operation of Power Supply Cooling Fan Motor**

	Mechanical Condition	Operation of Fan Motor
5	When turning the power switch ON.	Full speed for 2 seconds and then half speed.
6	Warming up.	Half speed
7	Pause mode	Stop
8	During printing	<ul style="list-style-type: none"> <li>• When printing is started: half speed</li> <li>• 20 seconds after printing is started: full speed</li> <li>• 15 seconds after printing is completed: half speed</li> <li>• At other time: half speed.</li> </ul>

**Mechanism Cooling Fan Motor is abnormal**

**Table 3-8. Mechanism Cooling Fan Motor is Abnormal**

No.	Check Item		Solution
1	At the power ON initialization sequence, does the mechanism cooling fan motor (M9) rotate? Check the rotation by its sound or by hand feeling wind.	No	Remove connector PJ28A and insert it again. Replace the fan motor.
Others			Replace PWB-A.

Ozone fan motor (M9) rotates full-time while polygon motor rotates.

- When polygon motor (M6) is ON: full speed
- Stops by opening cover.  
Cover: front cover, fusing cover, transportation cover, paper feed cassette door, double unit door.

When the mechanism cooling fan lock signal becomes active for 0.5 seconds, the printer detects that mechanism cooling fan motor is abnormal.

**Suction Fan Motor is abnormal**

**Table 3-9. Suction Fan Motor is Abnormal**

No.	Check Item		Solution
1	At the power ON initialization sequence, does the suction fan motor (M7) rotate? Check the rotation by its sound or by hand feeling wind.	No	Remove connector PJ3A and insert it again. Replace the fan motor.
Others			Replace PWB-A.

Suction fan motor (M7) rotates by two rotational speed; full speed / half speed.

- When transportation motor (M1) is rotating: Full speed
- When transportation motor (M1) is not operating: Half speed
- Cover open: Stop
- Other time: Half speed

When the suction fan lock signal becomes active for 0.5 seconds, the printer detects that suction fan motor is abnormal.

**Transfer Belt Fan Motor is abnormal**

**Table 3-10. Toner Absorption Fan Motor is Abnormal**

No.	Check Item		Solution
1	At the power ON initialization sequence, does the toner absorption fan motor (M11) rotate? Check the rotation by its sound or by hand feeling wind.	No	Remove connector PJ30A and insert it again. Replace the fan motor.
Others			Replace PWB-A.

Toner absorption fan motor (M11) rotates full-time while transportation motor (M1) rotates.

- When transportation motor (M1) is rotating: Full speed
- Cover open: Stop

When the transfer belt fan lock signal becomes active for 0.5 seconds, the printer detects that transfer belt fan motor is abnormal.

---

**Fusing Fan Motor is abnormal**

---

**Table 3-11. Fusing Fan Motor is Abnormal**

No.	Check Item		Solution
1	At the power ON initialization sequence, does the fusing fan motor (M10) rotate? Check the rotation by its sound or by hand feeling wind.	No	Remove connector PJ29A and insert it again. Replace the fan motor.
Others			Replace PWB-A.

Fusing fan motor (M10) rotates by two rotational speed; full speed / half speed.

- When fan is booted or warm-up is completed: Full speed for 2 seconds, and then half speed
- When transportation motor (M1) is rotating: Full speed
- When warm-up is completed: Half speed
- Cover open, pause: Stop

When the fusing fan lock signal becomes active for 0.5 seconds, the printer detects that fusing fan motor is abnormal.

---

**Main Motor is abnormal**

---

**Table 3-12. Main Motor is Abnormal**

No.	Check Item		Solution
1	Does the transportation motor (M1) rotate during printing?	No	Remove connector PJ21A and insert it again.
		Yes	Check that no weight applies on the each roller or gears.
Others			Replace PWB-A.

Detection of transportation motor (M1) rotation is detected 1 second after transportation motor (M1) starts rotating until the transportation motor (M1) stops.

When the transportation motor M\_Lock signal becomes active for 0.5 seconds, the printer detects that the transportation motor is abnormal.

---

**Fusing Motor is abnormal**

---

**Table 3-13. Fusing Motor is Abnormal**

No.	Check Item		Solution
1	Does the fusing motor (M4) rotate during printing?	No	Remove connector PJ22A and insert it again.
		Yes	Check that no weight applies on the each roller or gears.
Others			Replace PWB-A.

Detection of fusing motor (M4) rotation is detected 1 second after fusing motor (M4) starts rotating until the fusing motor (M4) stops.

When the fusing motor M\_Lock signal becomes active for 0.5 seconds, the printer detects that the fusing motor is abnormal.

---

**Fusing Pressure / Estrangement is abnormal**

---

**Table 3-14. Fusing Pressure / Estrangement is Abnormal**

No.	Check Item		Solution
1	Does the fusing unit upshot?	Yes	Install the fusing unit correctly.
2	Does the fusing pressure motor (M5) rotate? Check by its sound.	No	Remove connector PJ25A and insert it again. Replace fusing pressure motor.
		Yes	Replace the fusing pressure position sensor. Replace the pressure roller estrangement sensor.
Others			Replace PWB-A.

When one of the following items is detected, the printer detects that the driving motor is abnormal.

1. When the pressure state is not detected 4 seconds after the printer starts pressure roller to pressure.
2. When the estrangement state is not detected 4 seconds after the printer starts pressure roller to estrange.

---

**Laser is abnormal**

---

**Table 3-15. Laser is Abnormal**

No.	Check Item		Solution
1	Check the connector on the mechanical control board of the printhead and polygon motor.	-	Remove the connector PJ27A and insert it again. Remove the connector PJ12A and insert it again.
2	-	-	Replace the printhead unit. Replace the laser safety switch.
Others			Replace PWB-A.

When one of the following items is detected, the printer detects that the laser is abnormal.

1. When the polygon motor M\_Lock signal becomes inactive for 0.4 seconds 8 seconds after the polygon motor (M6) starts driving until the polygon motor (M6) stops, the printer detects that the laser is abnormal.
2. When the LD\_SOS signal is not detected for the specified time after the polygon motor is turned on and laser emission is started, the printer detects that the laser is abnormal.
3. When LD\_SOS signal is not detected during the printing (during laser emission), the printer detects laser is abnormal.

---

**Transfer Belt Rotation is Abnormal**

---

**Table 3-16. Transfer Belt Rotation is Abnormal**

No.	Check Item		Solution
1	During printing, does the transfer belt rotate? (Open the front cover and check it.)	No	Check if the transfer belt unit is installed correctly.
		No	Replace the transfer belt unit.
Others			Replace PWB-A.

1. The transfer belt rotation is detected since the transfer belt starts rotating until the transfer belt stops.
2. While the transfer belt is rotating, if the transfer belt position sensor (PC12) does not change, it is detected that the transfer belt is abnormal.

---

**Transfer Belt Cleaner Pressure / Estrangement is Abnormal**

---

**Table 3-17. Transfer Belt Cleaner Pressure / Estrangement is Abnormal**

No.	Check Item		Solution
1	During printing, does the belt cleaner motor rotate? (Check it by its sound.) Or remove the left cover, take a look from the front bottom and check it by the lever operation.	No	Remove connector PJ32A, PJ33A and insert it again. Remove connector PJ51, PJ61 and insert it again.
		No	Replace the belt cleaner estrangement sensor.
Others			Replace PWB-A.

1. The belt cleaner pressure is detected along with the color print and special print pressure / estrangement operation.
2. When the belt cleaner estrangement sensor (PC16) does not change within the specified period after the belt cleaner motor starts rotating, it is detected that the belt cleaner is abnormal.



---

**Developer Rack Rotation is Abnormal**

---

**Table 3-18. Developer Rack Rotation is Abnormal**

No.	Check Item		Solution
1	During printing, does the rack motor (M3) rotate?	No	Remove connector PJ32A, PJ33A and insert it again. Remove connector PJ41 and insert it again.
2	With the power off, press the rack release button and check if you can rotate the toner rack manually.	Yes	Replace the rack black position sensor (PC6).
Others			Replace PWB-A.

1. When initializing the toner rack position, if the rack black position sensor (PC6) does not become ON within 3 seconds, it is detected that toner rack is abnormal.
2. When the black toner should be at the development position, if the rack black position sensor (PC6) does not become ON within 0.3 seconds, it is detected that the toner rack is abnormal.
3. When the rack black position sensor (PC6) becomes ON within 0.3 seconds after the rack motor (M3) is halted, it is detected that the toner rack is abnormal.

---

**Multi Manual Paper Load Push-up is Abnormal**

---

**Table 3-19.  
Multi Manual Paper Load Push-up is Abnormal**

No.	Check Item		Solution
1	Does the manual tray push paper to the paper load roller?	No	Arrange paper on the manual tray.
2	Does the manual tray paper load roller one-way clutch have the claws?	No	Replace the one-way clutch gear.
		Yes	Replace the manual tray paper load solenoid.
Others			Replace PWB-A.

1. MPT push-up tray position is detected while loading paper from the manual tray.
2. If the output of the manual tray upper position sensor (PC15) does not change even after the specified amount of time passed after the manual tray paper load solenoid (SL8) becomes ON, it is detected that the MPT push-up plate is abnormal.

---

**OHP Sensor is Abnormal**

---

**Table 3-20. OHP Sensor is Abnormal**

No.	Check Item		Solution
1	Are the light emission window and light receiving window of OHP sensor dirty?	No	Clean the OHP sensor window.
2	Does any dust or a bit of paper attach on the other side OHP sensor reflective window?	Yes	Clean the OHP sensor reflective window.
Others			Replace PWB-A.

- OHP sensor is detected while the transportation motor (M1) is pre-rotating.
- Since no paper exist during the pre-rotation, if the sensor detects it is not OHP, it detects that the OHP sensor is abnormal.

**3.2.4.3 Controller Related Service Call Error Messages**
**Table 3-21. Controller Related Service Call Error Messages**

Error Category e	Error Code ffff	Explanation
C	0017	CPU Error (Undefined interrupt occurred)
C	0081	CPU Error (TLB correction exception)
C	0082	CPU Error (TLB miss exception [Load/Fetch])
C	0083	CPU Error (TLB miss exception [Store])
C	0084	CPU Error (Address Error Exception [Load/Fetch])
C	0085	CPU Error (Address Error Exception [Store])
C	0086	CPU Error (Bus Error Exception [Fetch])
C	0087	CPU Error (Bus Error Exception [Load/Store])
C	0088	CPU Error (SYSCALL Exception)
C	0089	CPU Error (Break Exception)
C	0090	CPU Error (Reserve Command Exception)
C	0091	CPU Error (Coprocessor Not Used Exception)
C	0092	CPU Error (FPU Exception)
C	0093	CPU Error (TLB Exception)
C	0094	CPU Error (XTLB Exception)
C	0095	CPU Error (Cache Exception)
C	0096	CPU Error (Trap Exception)
C	0097	CPU Error (FPU Exception)
C	0098	CPU Error (Watch Exception)
C	0128-0254	CPU Error (Undefined Trap)
C	0255	CPU Error (NMI Exception)
C	0256	CPU Error (Divide by 0)
C	0257	CPU Error (Computation Overflow)
C	0258	CPU Error (Break was generated)
C	0800	IPL Error (Controller defective.)
C	0998	Engine communication error (At power on)

Table 3-21. Controller Related Service Call Error Messages

Error Category e	Error Code ffff	Explanation
C	0999	Engine firmware in Flash ROM is not exist.
C	1002	Standard RAM Error (When RAM equivalent to the standard size is not installed, etc.)
C	1010	Verify Error
C	1020	RAM Error (Slot 0)
C	1021	RAM Error (Slot 1)
C	1100	ROM Check Sum Error (bits 0~15) (Font)
C	1101	ROM Check Sum Error (bits 16~31) (Font)
C	1120	ROM Check Sum Error (bits 0~7) (Program)
C	1121	ROM Check Sum Error (bits 8~15) (Program)
C	1122	ROM Check Sum Error (bits 16~23) (Program)
C	1123	ROM Check Sum Error (bits 24~31) (Program)
C	1170	Optional Font ROM Check Sum Error
C	1180	Optional ROM Module A Check Sum Error
C	1181	Optional ROM Module B Check Sum Error
C	1185	Unsupported ROM Module
C	1200	EEPROM Write Error
C	1210	EEPROM Write Count Limit
C	1400	Engine Initialization Malfunction
C	1500	CCNV Hardware Error
C	1550	Compression SRAM Initialization Hardware Error
C	1600	Video Related Hardware Error (including PWM IC calibration error)
C	1610	Video Related Hardware Error (VCNV error)
C	1700	Internal Network Hardware Error
C	1999	Other Hardware Error
C	2000	Software Error

### 3.3 Image Quality Troubleshooting

Table 3-22. Image Quality Troubleshooting

Abnormal Image	Cause	Step	Solution
No image (all white) 	OHP is selected and plain paper is loaded. (white paper eject mode)	1	Configure the paper load device and paper type by driver.
	<ul style="list-style-type: none"> <li>Bias contact failure (toner cartridge)</li> <li>Contact failure (transfer roller)</li> </ul>	1	<ul style="list-style-type: none"> <li>Re-install the toner cartridge.</li> <li>If it occurs for one color, replace the color toner cartridge.</li> <li>Re-install the transfer roller unit.</li> </ul>
	<ul style="list-style-type: none"> <li>Connector contract failure (P/H)</li> <li>Data output failure</li> </ul>	2	<ul style="list-style-type: none"> <li>remove P/H connector PJ12A and insert it again.</li> <li>Replace the printhead.</li> </ul>
		3	Replace the HV1 (high voltage board).
All black 	<ul style="list-style-type: none"> <li>Bias setting failure (photoconductor)</li> <li>Charging failure (photoconductor)</li> </ul>	1	Replace the photoconductor.
		2	Replace HV1 (high voltage) board.

Table 3-22. Image Quality Troubleshooting

Abnormal Image	Cause	Step	Solution
White out / Black point 	Foreign objects on the toner cartridge.	1	Replace the toner cartridge.
	Foreign objects on the photoconductor.	2	Replace the photoconductor.
	Foreign objects on the transfer belt.	3	<ul style="list-style-type: none"> <li>Clean the transfer belt.</li> <li>Replace the transfer belt unit.</li> </ul>
	Foreign objects on the transfer belt.	4	<ul style="list-style-type: none"> <li>Clean the fusing belt.</li> <li>Replace the oil coating roller.</li> <li>Replace the fusing unit.</li> </ul>
Back of paper gets dirty 	Paper path is dirty.	1	<ul style="list-style-type: none"> <li>Clean the paper path.</li> <li>Replace the toner cartridge.</li> </ul>
	Transfer roller is dirty.	2	Replace the transfer roller unit.
	Fusing pressure roller is dirty.	3	<ul style="list-style-type: none"> <li>Clean the pressure roller.</li> <li>Replace the oil coating roller.</li> </ul>
Image is overlapping 	<ul style="list-style-type: none"> <li>Foreign object on the developer.</li> <li>Used toner low consumption mode too much.</li> </ul>	1	Replace the toner cartridge.
	High density	2	<ul style="list-style-type: none"> <li>Replace the photoconductor.</li> <li>Replace HV1 (high voltage board).</li> </ul>

Table 3-22. Image Quality Troubleshooting



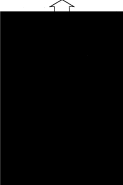

Abnormal Image	Cause	Step	Solution
Low image density 	OPC drum is at the end of life. AIDC failure	1	Replace the drum cartridge.
	Middle transfer failure Paper transfer failure Contact failure (transfer roller)	2	<ul style="list-style-type: none"> <li>Replace the transfer belt unit.</li> <li>Re-install the transfer roller unit.</li> <li>Replace the transfer roller.</li> </ul>
		3	Replace HV1 (high voltage board).
White line. Black line. 	<ul style="list-style-type: none"> <li>Foreign object or scratch on the developer.</li> <li>Scratch on the OPC drum.</li> </ul>	1	<ul style="list-style-type: none"> <li>Replace the drum cartridge.</li> <li>Replace the toner cartridge.</li> </ul>
	Scratch on the transfer belt.	2	Replace the transfer belt unit.
	Scratch on the fusing belt.	3	Replace the fusing unit.
	PH dust proof filter is dirty.	4	Clean PH dust proof filter.
Offset image 	<ul style="list-style-type: none"> <li>Image memory</li> <li>Transfer belt offset</li> </ul>	1	<ul style="list-style-type: none"> <li>Replace the OPC drum.</li> <li>Replace the transfer belt unit.</li> </ul>
	Fusing offset	2	<ul style="list-style-type: none"> <li>Replace the oil coating roller.</li> <li>Replace the fusing unit.</li> </ul>

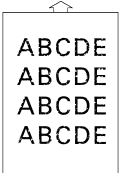
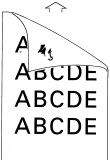
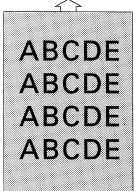
Table 3-22. Image Quality Troubleshooting

Abnormal Image	Cause	Step	Solution
Color overlay offset 	Toner cartridge installation failure	1	Re-install the toner cartridge.
	Middle transfer failure	2	Replace the transfer belt unit.
Color duplication failure 	AIDC failure	1	Re-install the transfer belt unit.
	Paper transfer failure	2	Replace the transfer belt unit.
Varied density 	Contact failure	1	Re-install the transfer roller unit. Replace the transfer roller unit.
	If this error occurs only for one side, toner cartridge is not installed firmly.	2	Re-install the toner cartridge or replace it.

**Table 3-22. Image Quality Troubleshooting**

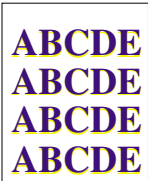
Abnormal Image	Cause	Step	Solution
	Paper is wet.	1	Use paper after kept in the room for a while.
	White smear	2	Replace the fusing unit.
	If it occurs only for the optional duplex paper feed.	3	Replace the optional duplex unit.
	1-2 mm pitch	-	Replace the printhead.
	35mm develop pitch irregularity	-	Replace the color toner cartridge.
	75mm transfer roller		Replace the transfer roller unit.
	95mm OPC drum	-	Replace the OPC drum.
	204mm fusing belt	-	Replace the fusing unit.
	Rear end 35mm		Replace the fusing unit.
	Line and point that occurs at the regular page.		Replace the belt unit.

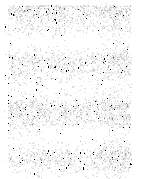
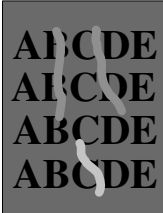
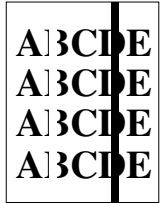
**CHAPTER**

**4**

**DISASSEMBLY AND ASSEMBLY**

## 4.1 Overview

This chapter describes disassembly/assembly of the printer.

### 4.1.1 Cautions

Read the following caution before disassembling the printer.

- Caution on disassembling/ adjusting the printer.



- Be sure to turn the printer power off and disconnect the power cable from the AC socket.
- Since the printer weighs 44.5kg, including the optional units, be sure to carry it with 2 people.
- When servicing parts around the fuser, make sure the fuser and adjacent parts are cool enough.
- Before printing, check that all printer parts are installed.
- If you need to operate the printer before reassembling, note the points below:
  1. Be careful not to get your hand or clothes caught in the rotating parts such as rollers and cooling fan.
  2. Never touch the components in the electrical circuit or high voltage circuit.

- Caution on lithium battery replacement



- When replacing the old lithium battery with a new one, be sure to use the one that is specified by the parts list or equivalent.
- When installing the new battery, be sure to set it correctly paying attention to its polarity.
- Be sure to dispose of the old battery according to the local regulations.
- Do not throw away the old battery to the personal land.

### 4.1.2 Service Tools

Table 4-1. Service Tools





Name	Availability	Part Code
Phillips Screwdriver (No.1)	Commercially available	B743800100
Phillips Screwdriver (No.2)	Commercially available	B743800200
Standard Screwdriver	Commercially available	B74300100
Tweezers	Commercially available	B64100100
Pliers	Commercially available	B740400100



### 4.1.3 Screws, Small Parts

The table below lists the screws and small parts used in the printer. Be sure to use them at the correct positions that are specified with the reference numbers in the exploded diagrams.

**Table 4-2. Screws and Small Parts Used in the Printer**

Appearance	Reference Number	D x L (mm), Color	Application
 9735	3541	3 x 8, Silver	For Housing part installation
 9735	3504	3 x 8, Copper	For internal part installation
 9739	3704	3 x 8, Copper	For internal part installation
 9646	1308	3 x 8, Silver	For lever, tab installation
 9712	8301	-	For metallic housing installation

### 4.1.4 Fuses

The fuses used in the printer are as shown below:

**Table 4-3. Fuses Used in the Printer**

Board Name	Symbol	Specifications
HV1	F1	125V-3.15A
HV2	F001	125V-3.15A
PU1	F1	100V:AC125V-10A 220V:AC250V-5.0A
	F2A	100V:AC250V-15A 220V:AC250V-5.0A

## 4.2 Disassembling Procedure

### 4.2.1 Overview

See the following page for the disassembling flowcharts.

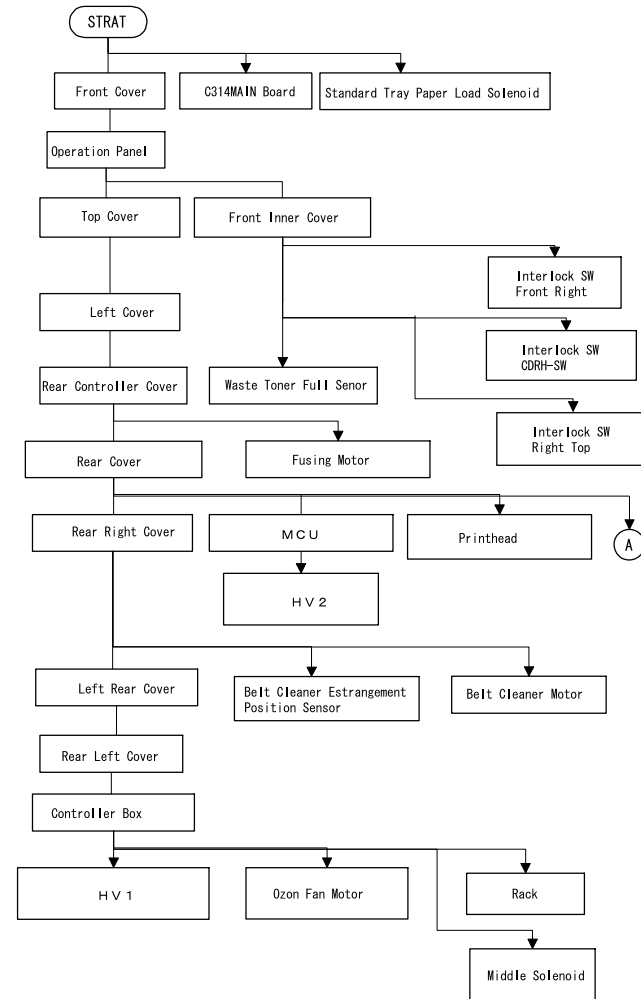

DisFlow

Figure 4-1. Disassembly Flowchart - 1

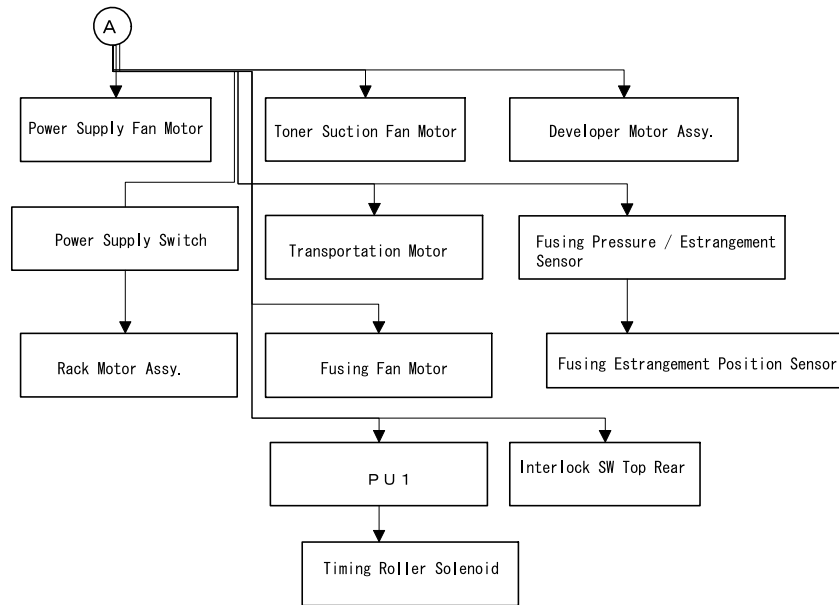
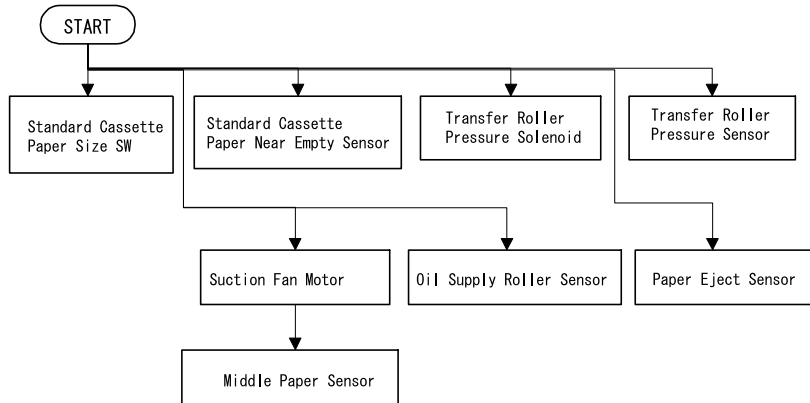

Figure 4-2. Disassembly Flowchart - 2

DisFlow2

### 4.2.2 Before Disassembling the Printer

1. Remove the standard cassette and Large Capacity Paper Cassette if installed.
2. Open the Front Cover.
3. Remove the Toner Cartridge (Y/M/C/K), Drum Cartridge, Transfer Belt, Oil Roller, and Fuser Unit.

**NOTE:** Do not remove the P/H dust proof filter to prevent toner from spilling over the Print Head during servicing.

### 4.2.3 Outer Cover Removal

#### 4.2.3.1 Front Cover Removal

1. Perform the pre-operation. (See “Before Disassembling the Printer” on page -123.)
2. Remove 1 screw securing the band.
3. Open the Front Cover to the right and remove the right and left hinge pins from the Front Cover.
4. Remove the Front Cover.

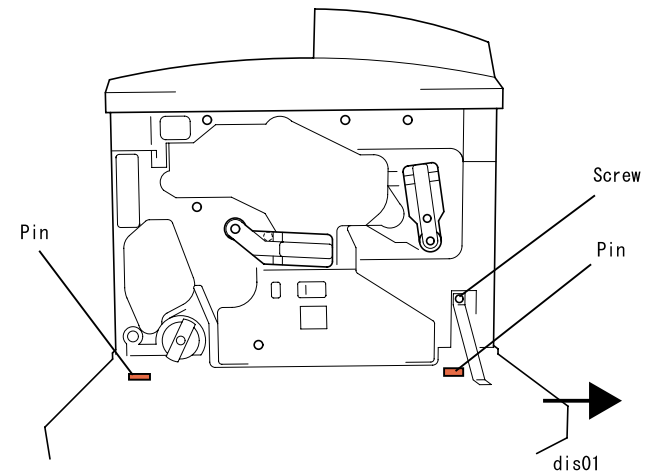

Figure 4-3. Front Cover Removal

### 4.2.3.2 Operation Panel Removal

1. Remove the Front Cover. (See "Front Cover Removal" on page -123.)
2. Remove the screws securing the Operation Panel. (3 from the front and 1 from the top)
3. Disconnect the harness from the connector on the Operation Panel and remove the Operation Panel.

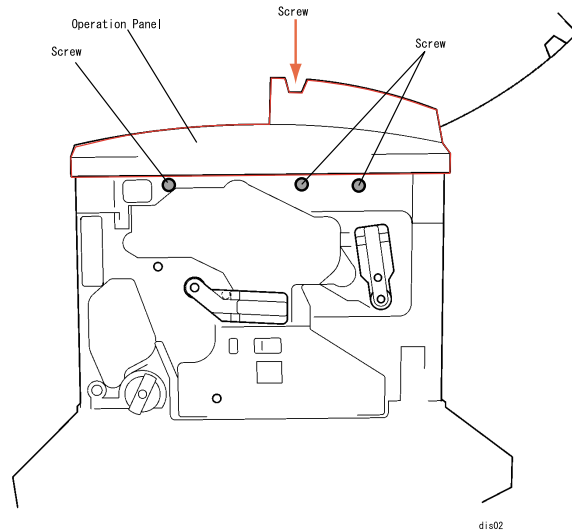

Figure 4-4. Operation Panel Removal

### 4.2.3.3 Front Inner Cover Removal

1. Remove the Operation Panel. (See "Operation Panel Removal" on page -124.)
2. Peel off the label on the rack rotation tab a little and remove 1 screw securing the rack rotation tab to the printer frame.
3. Peel off the label on the transfer roller estrangement lever a little and remove 2 screws securing the transfer roller estrangement lever to the printer frame.
4. Remove 3 screws securing the Front Inner Cover to the printer frame.
5. Release the left hook on the Front Inner Cover and remove the Front Inner Cover.

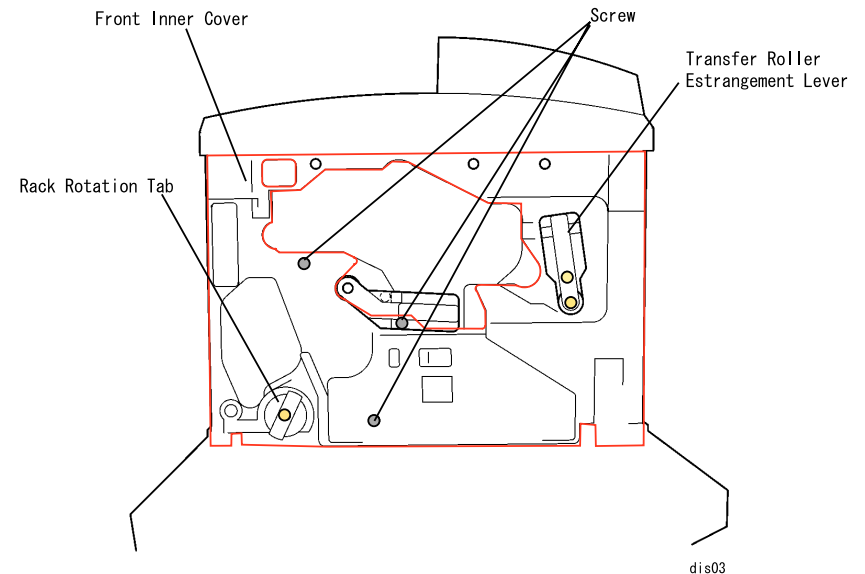

Figure 4-5. Front Inner Cover Removal

### 4.2.3.4 Top Cover Removal

1. Remove the Operation Panel. (See "Operation Panel Removal" on page -124.)
2. Remove the cover for the optional unit cover located at the top rear side of the Top Cover.
3. Remove 2 screws (1 under the option cover and the other at the rear right securing the Top Cover and Rear Cover together), and remove the Top Cover.

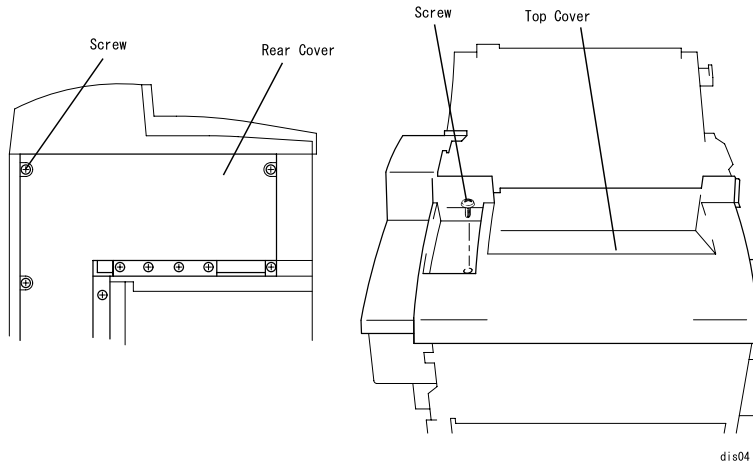

Figure 4-6. Screws Fixing the Top Cover

4. Through the transfer belt installation hole, release the hook fixing the Top Cover to the printer frame and remove the Top Cover.

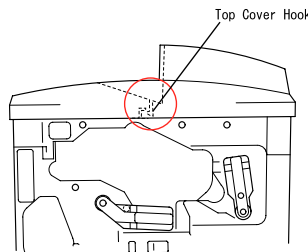

Figure 4-7. Hook on the Top Cover

### 4.2.3.5 Left Cover Removal

1. Remove the Top Cover. (See "Top Cover Removal" on page -125.)
2. Remove 3 screws securing the Left Cover.
3. Pull the Left Cover to the front and lift it up to release 3 hooks at the bottom.
4. Move the Left Cover down to release 3 hooks along the top edge, and remove the Left Cover.

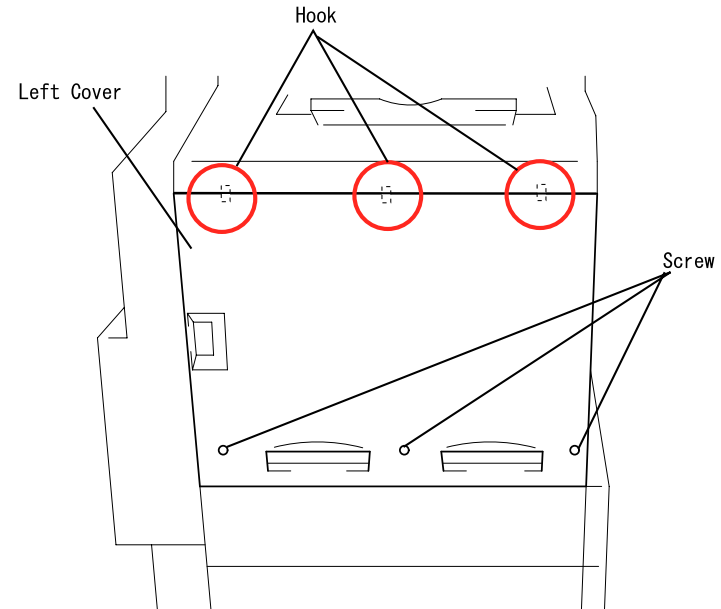

Figure 4-8. Left Cover Removal



**When installing the Left Cover to the printer frame, be sure to set the reinforcing plate between them and fasten the screws.**

#### 4.2.3.6 Rear Controller Cover Removal

1. Remove 4 screws securing the Controller Cover to the rear side of the printer (Rear side: 3 screws, Left side: 1 screw).

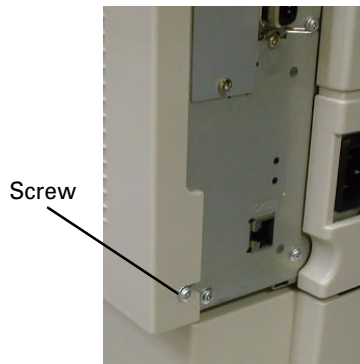

Figure 4-9. Rear Controller Cover Removal

### 4.2.3.7 Rear Cover Removal

1. Remove the Rear Controller Cover. (See "Rear Controller Cover Removal" on page -126.)
2. Remove 11 screws securing the Rear Cover and remove the Rear Cover.

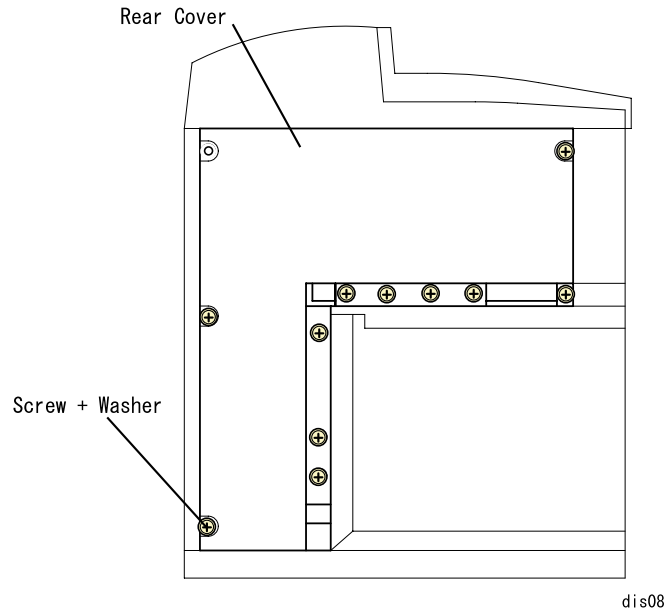

Figure 4-10. Rear Cover Removal



Among the screws securing the Rear Cover, the bottom one has a washer. This is to allow electrical continuity between the coated cover and printer frame.

### 4.2.3.8 Rear Right Cover Removal

1. Remove the Rear Cover. (See "Rear Cover Removal" on page -127.)
2. Remove 4 screws securing the Rear Right Cover and remove the Rear Right Cover.

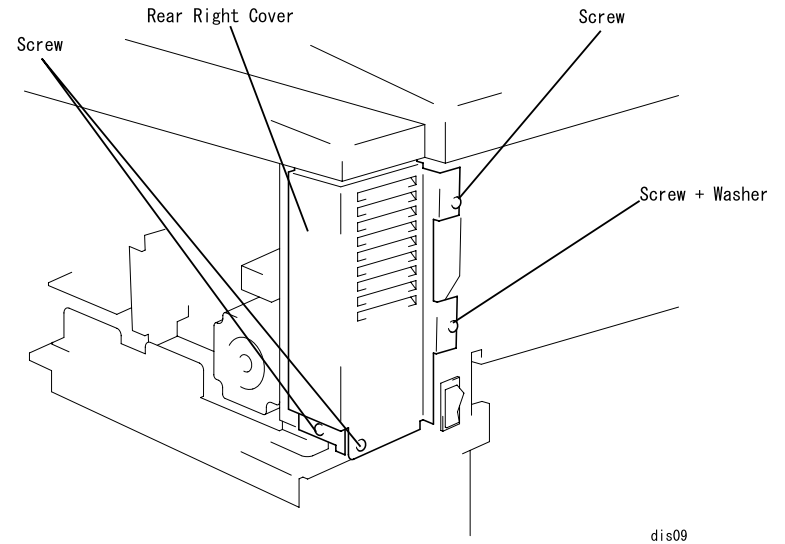

Figure 4-11. Rear Right Cover Removal



As shown in the figure above, one of the screws securing the Rear Right Cover has a washer. This is to allow electrical continuity between the coated cover and printer frame.

#### 4.2.3.9 Left Rear Cover Removal

1. Remove the Rear Right Cover. (See "Rear Right Cover Removal" on page -127.)
2. Remove 1 screw securing the Left Rear Cover and remove the Left Rear Cover.

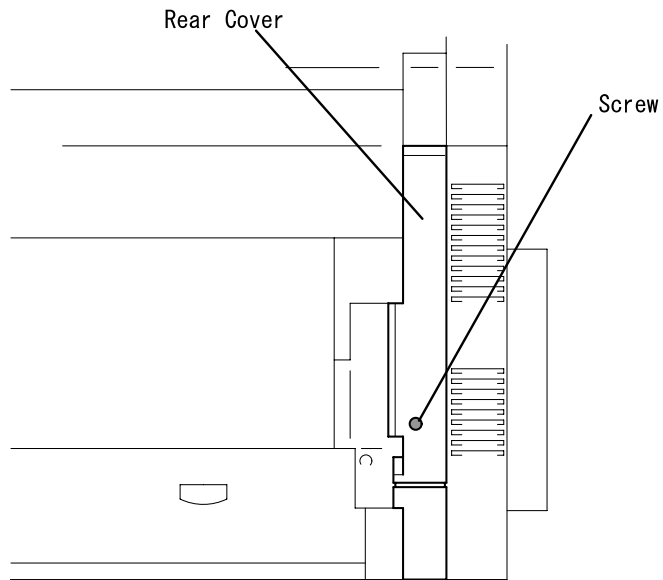

dis10

**Figure 4-12. Left Rear Cover Removal**

#### 4.2.3.10 Rear Left Cover Removal

1. Remove the Left Rear Cover. (See "Left Rear Cover Removal" on page -128.)
2. Remove 3 screws securing the Rear Left Cover and remove the Rear Left Cover.

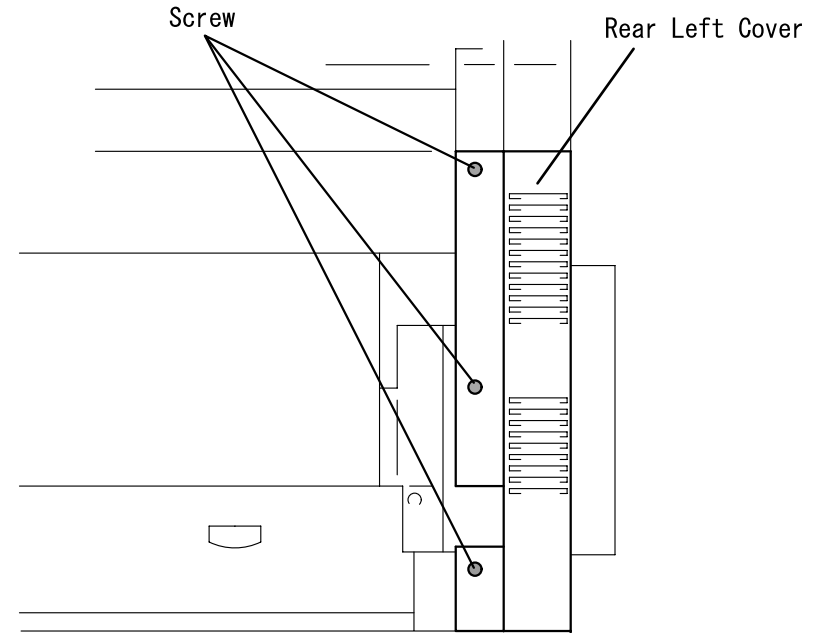

dis11

**Figure 4-13. Rear Left Cover Removal**



## 4.2.4 C314MAIN Board

### 4.2.4.1 C314MAIN Board Removal

1. Remove the Rear Controller Cover (See 4.2.3.6 "Rear Controller Cover Removal" on page 126.)
2. Remove 7 screws securing the C314MAIN Board to the Controller Box

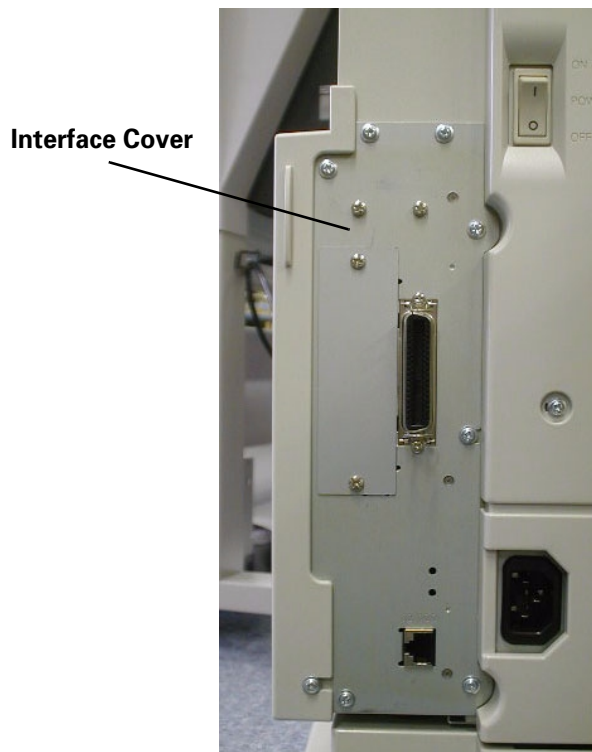

Figure 4-14. C314MAIN Board Removal

3. Remove a screw(A) securing the C314MAIN Board and an earth wire of the Controll Panel harness.  
Remove the harness from the connector of the MAIN Board.

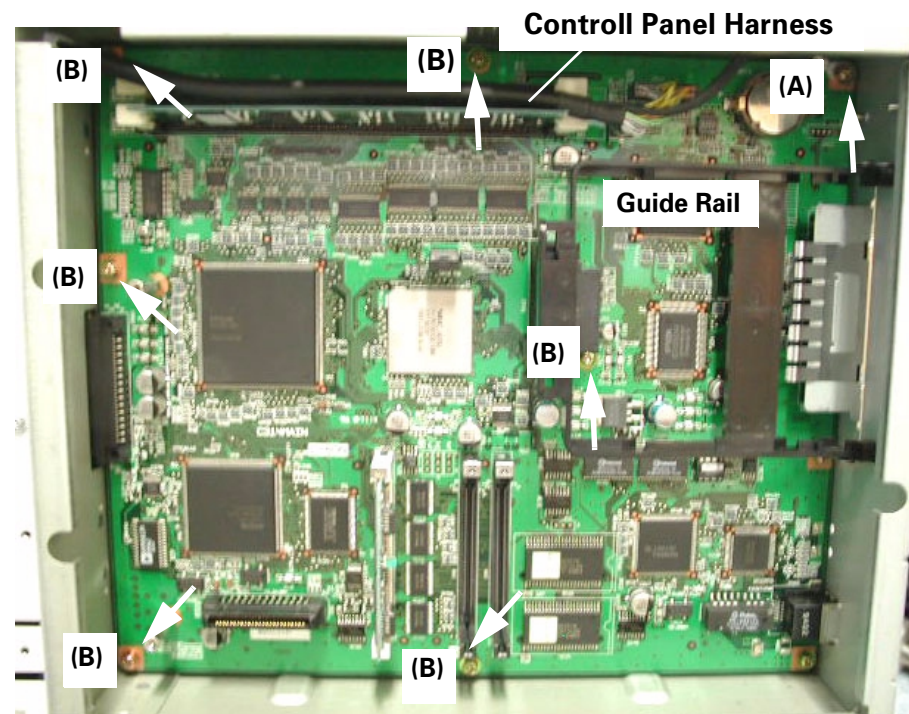
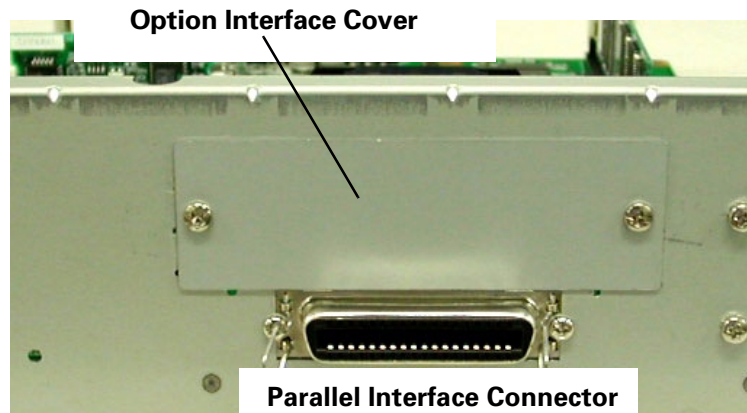

Figure 4-15. Screws of the C314MAIN Board (1)

4. Remove 6 screws(B) securing the Controller Box to the C314MAIN Board.
5. Pull out the C314MAIN Board with the Interface Cover.



**Figure 4-16. Option Interface Cover Removal**

6. Remove 2 screws securing the Option Interface Cover to the C314MAIN board.
7. Remove 2 screws securing the Parallel Interface Connector to the Interface Cover.
8. Remove the Guide Rail for the Option Interface Connector.
9. Remove 2 screws securing the Interface Cover to the C314MAIN Board.

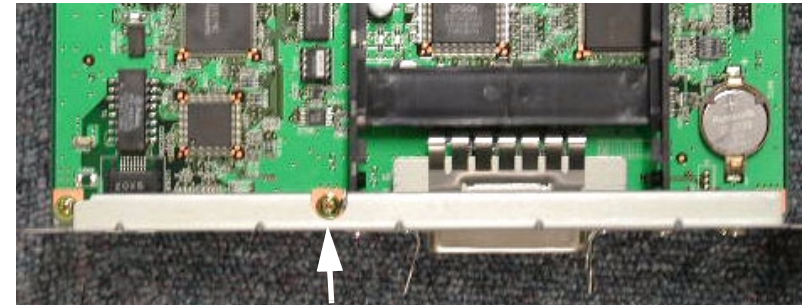

**Figure 4-17. Screws of the C314MAIN Board (2)**

#### 4.2.4.2 Controller Box Removal

1. Remove the Rear Right Cover.( See 4.2.3.10 "Rear Left Cover Removal"on page 128.)
2. Remove 8 screws securing the Control Box. (Note: 2 screws among 8 screws are securing both the Controller Box and the MCU.)
3. Remove the Controller Box.

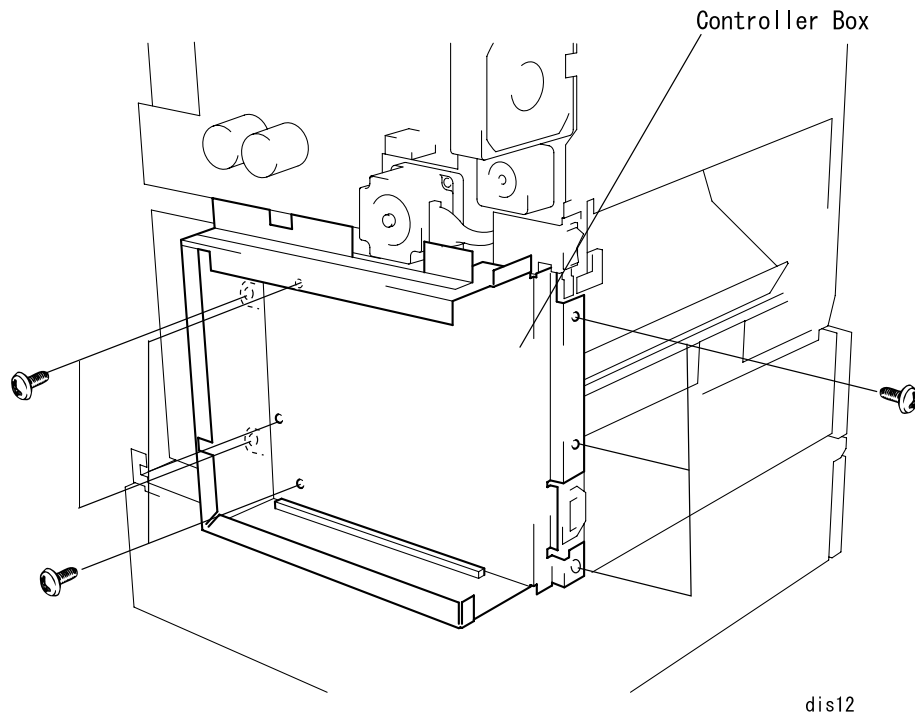

Figure 4-18. Controller Box Removal

#### 4.2.5 MCU (PWB-A Board) Removal

1. Remove the Rear Controller Cover. (See "Rear Controller Cover Removal" on page -126.)
2. Remove the Rear Cover. (See "Rear Cover Removal" on page -127.)
3. Disconnect the twenty 9 connectors for the MCU and remove 3 screws securing the MCU.

**NOTE:** MCU is secured with 5 screws but two of them are removed when the Controller Box is removed.

4. Remove the MCU by pulling it to the left making sure the connector on

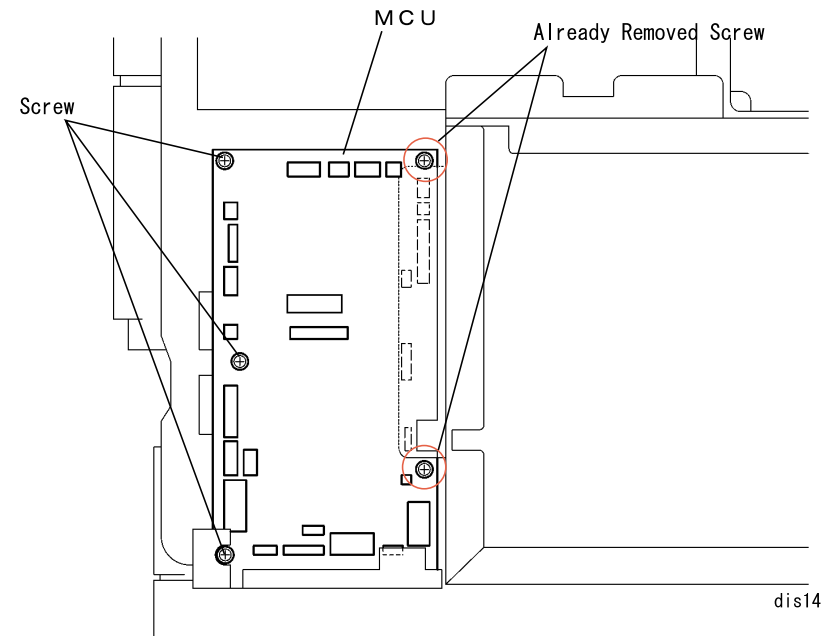

Figure 4-19. MCU (Mechanical Controller Board) Removal



The connector PJ6 on the MCU is blank.

## 4.2.6 PU1 (Power Supply Board) Removal

1. Remove the Rear Controller Cover. (See "Rear Controller Cover Removal" on page -126.)
2. Remove the Rear Left Cover. (See "Rear Left Cover Removal" on page -128.)
3. Disconnect 5 connectors for the PU1.
4. Remove 4 screws, board support, and contact plate. Then remove the PU1.

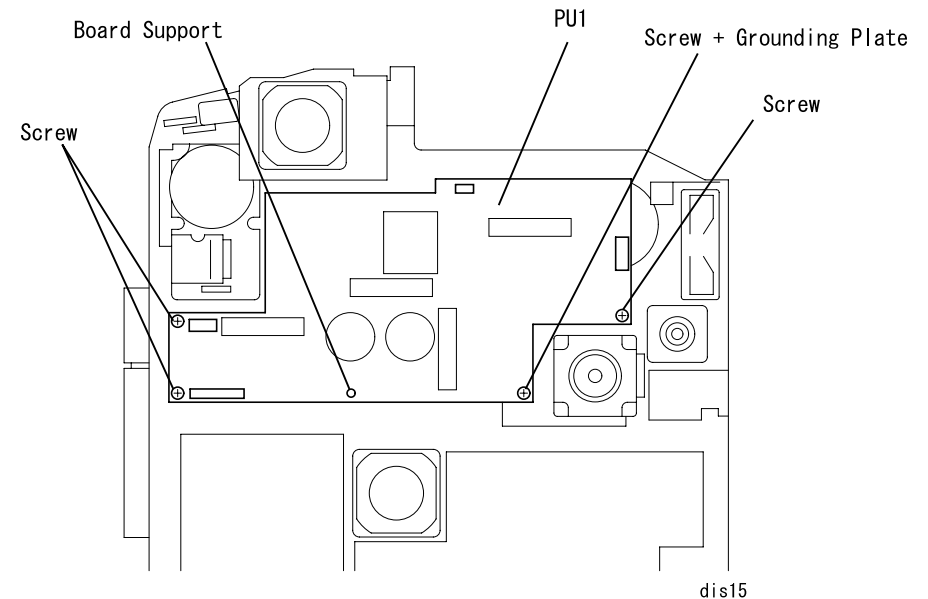

Figure 4-20. PU1 (Power Supply Board) Removal

## 4.2.7 High Voltage Board (HV1, HV2) Removal

### 4.2.7.1 HV1 (High Voltage Board) Removal

1. Remove the Rear Controller Cover. (See "Rear Controller Cover Removal" on page -126.)
2. Remove the Rear Cover. (See "Rear Cover Removal" on page -127.)
3. Remove the Controller Box. (See "Controller Box Removal" on page 131.)
4. Remove 6 connectors, 2 screws, and 4 board supports from the HV1 Board.
5. Remove the insulation sheet under the HV1.

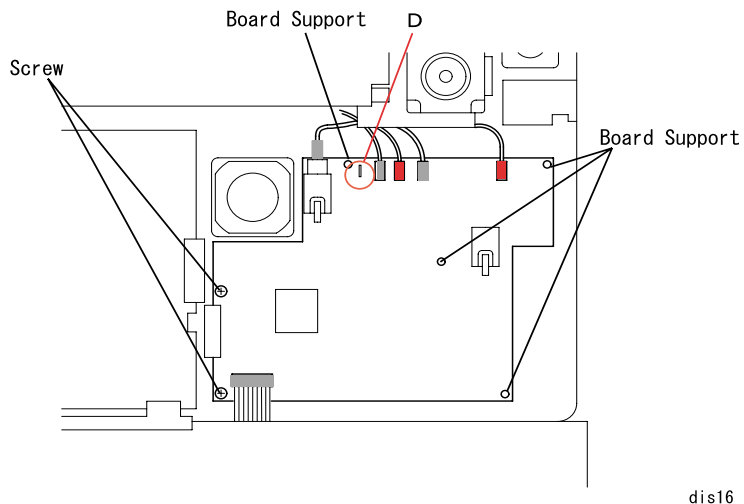

Figure 4-21. HV1 (High Voltage Board) Removal

dis16



The D terminal on the HV1 is not used.

### 4.2.7.2 HV2 (High Voltage Board) Removal

1. Remove the Rear Controller Cover. (See "Rear Controller Cover Removal" on page -126.)
2. Remove the Rear Cover. (See "Rear Cover Removal" on page -127.)
3. Disconnect the twenty 9 connectors from the MCU and discharge harness for the HV2 and the transfer roller from the transfer roller.
4. Remove 2 screws securing the PWB-A support plate to the printer frame.
5. Remove 2 screws securing the PWB-A and Controller Box. (See "Controller Box Removal" on page 131.)
6. Remove the PWB-A support plate.
7. Remove 2 connectors, 3 board supports, and 1 screw from the PPWB-A support plate, and remove the HV2 Board.

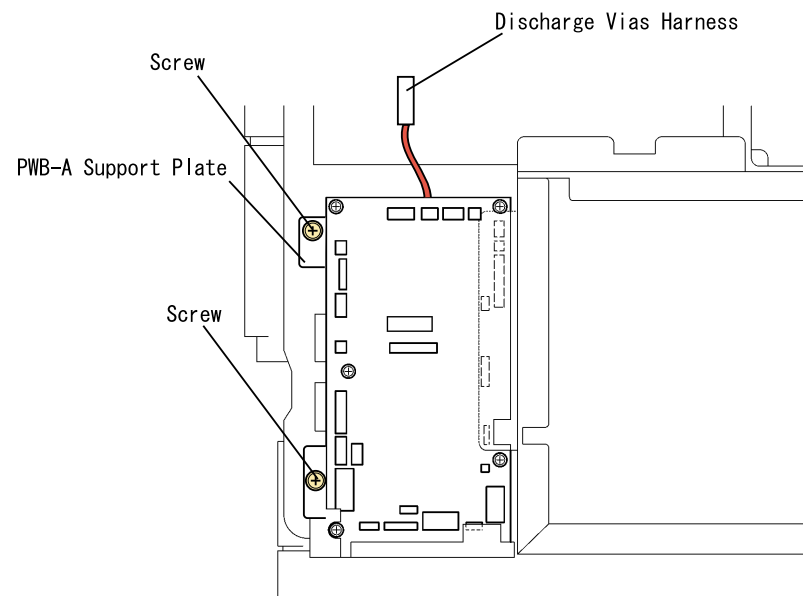
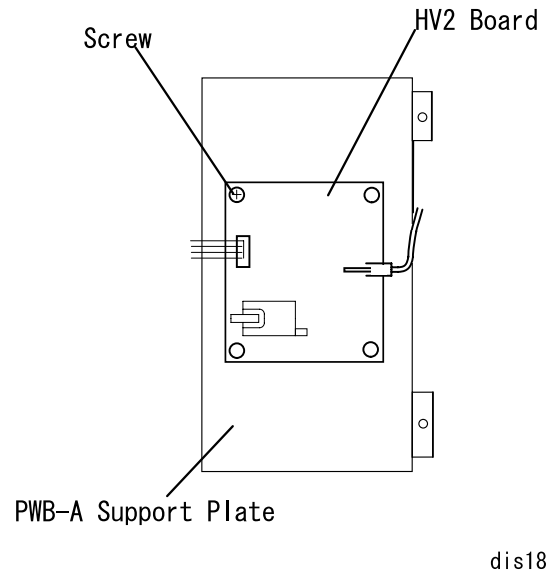

Figure 4-22. PWB-A Support Plate Removal

dis17



**Figure 4-23. HV2 (High Voltage Board) Removal**

#### 4.2.8 Fusing Motor Removal

1. Disconnect the fusing motor harness from the fuser motor board.
2. Remove 4 screws securing the Fusing Motor and remove the Fusing Motor.

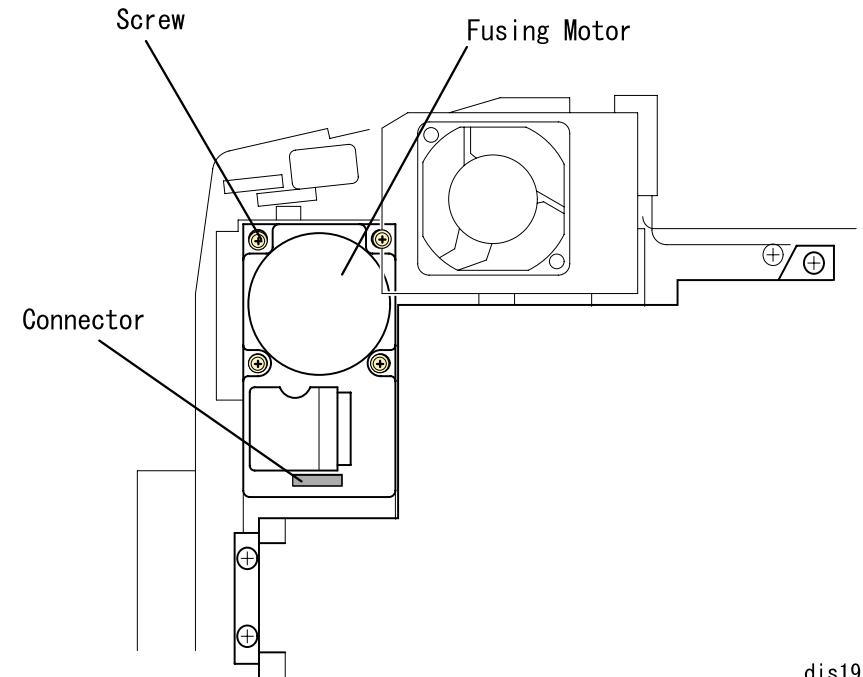
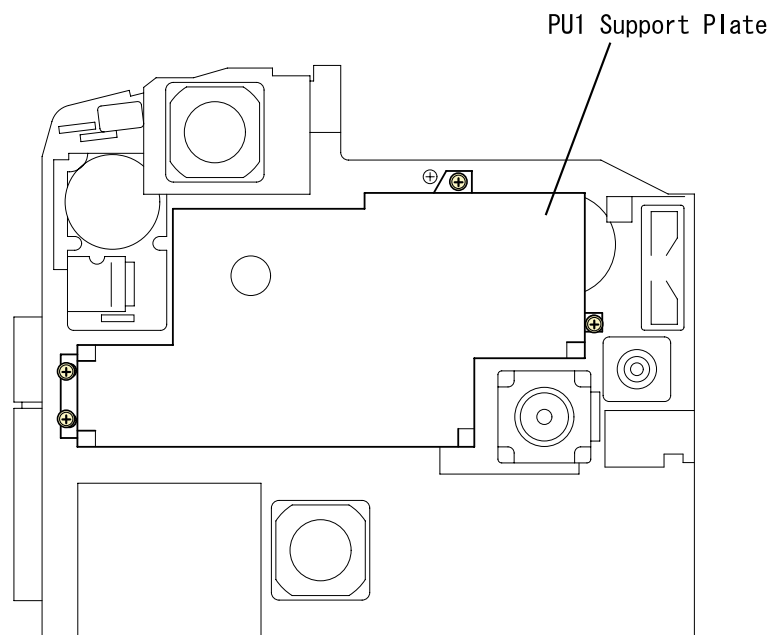

**Figure 4-24. Fusing Motor Removal**

## 4.2.9 Transfer Motor Removal

### 4.2.9.1 PU1 Support Plate Removal

1. Remove the Rear Controller Cover. (See "Rear Controller Cover Removal" on page -126.)
2. Remove the Rear Cover. (See "Rear Cover Removal" on page -127.)
3. Remove 5 harnesses connecting to the PU1 from the connectors. (See "PU1 (Power Supply Board) Removal" on page -132.)
4. Remove 4 screws securing the PU1 Support Plate and remove the PU1 Support Board.



dis20

**Figure 4-25. PU1 Support Plate Removal**

### 4.2.9.2 Transfer Motor Removal

1. Remove the PU1 Support Board. (See "PU1 Support Plate Removal" on page -135.)
2. Remove the transfer motor connector and 4 screws securing the Transfer Motor, and remove the Transfer Motor.

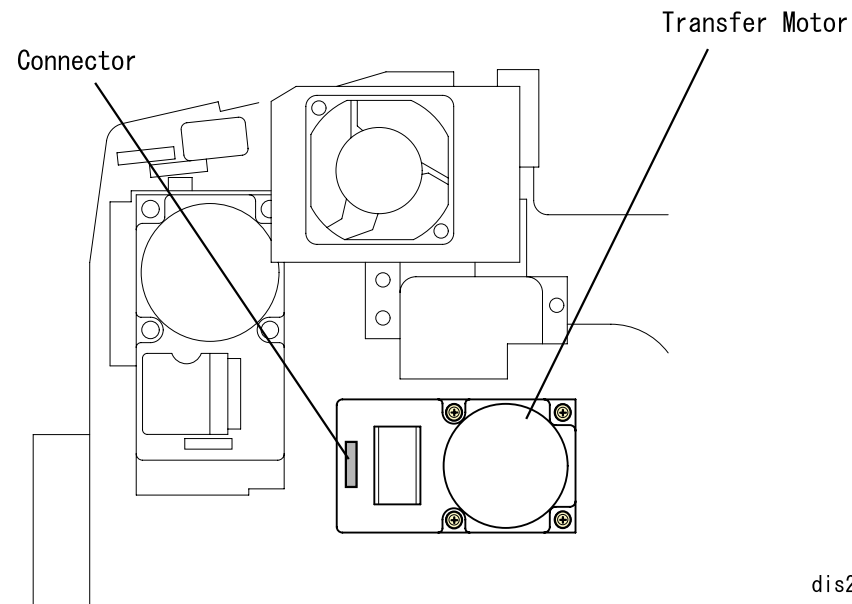

dis21

**Figure 4-26. Transfer Motor Removal**

## 4.2.10 Fusing Pressure Motor Removal

1. Remove the PU1 Support Board. (See "PU1 Support Plate Removal" on page -135.)
2. Remove the harnesses from the connectors on the Fusing Pressure Motor.
3. Remove 4 screws securing the Fusing Pressure Motor Support Board to the printer frame and the grounding screw.
4. Remove 2 screws securing the Fusing Pressure Motor, and remove the Fusing Pressure Motor.

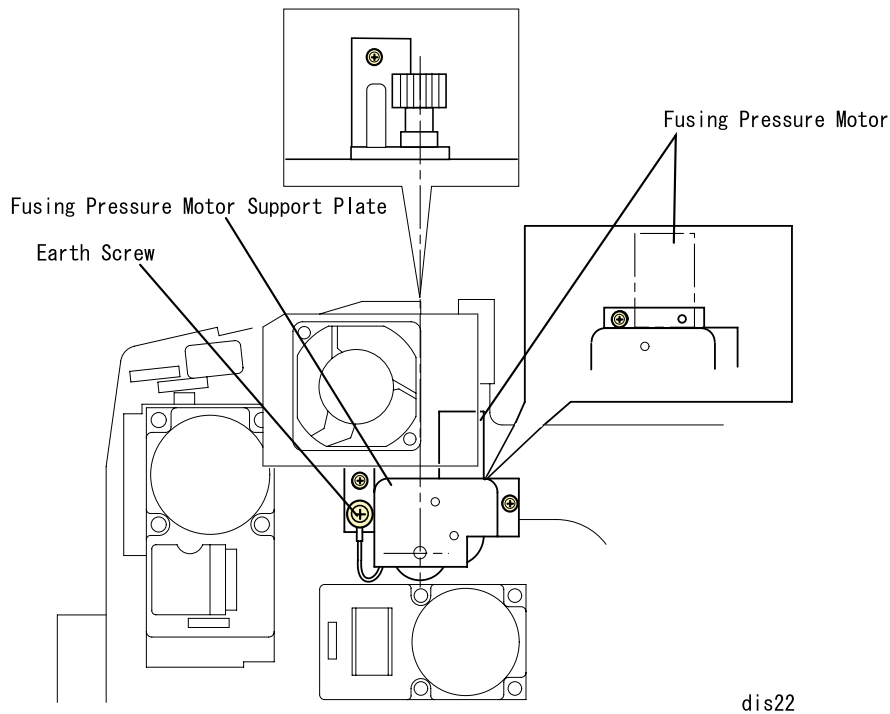
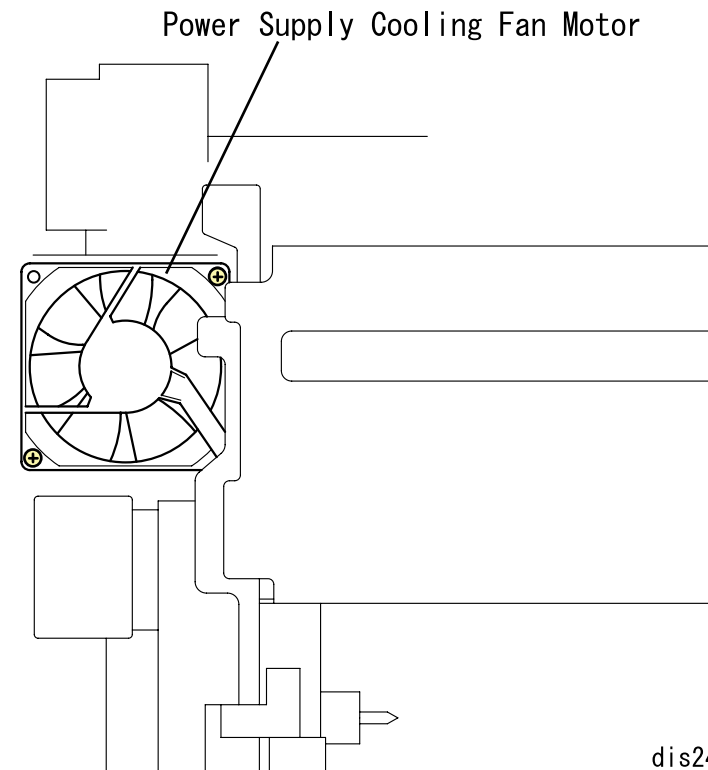

**Figure 4-27. Fusing Pressure Motor Removal**

## 4.2.11 Fan Motor Removal

### 4.2.11.1 Power Supply Fan Motor Removal

1. Remove the Rear Controller Cover. (See "Rear Controller Cover Removal" on page -126.)
2. Remove the Rear Right Cover. (See "Rear Right Cover Removal" on page -127.)
3. Free the harness from 5 harness clamps.
4. Disconnect the power supply fan motor harness and remove 2 long screws securing the Power Supply Fan Motor, and remove the Power Supply Fan Motor.

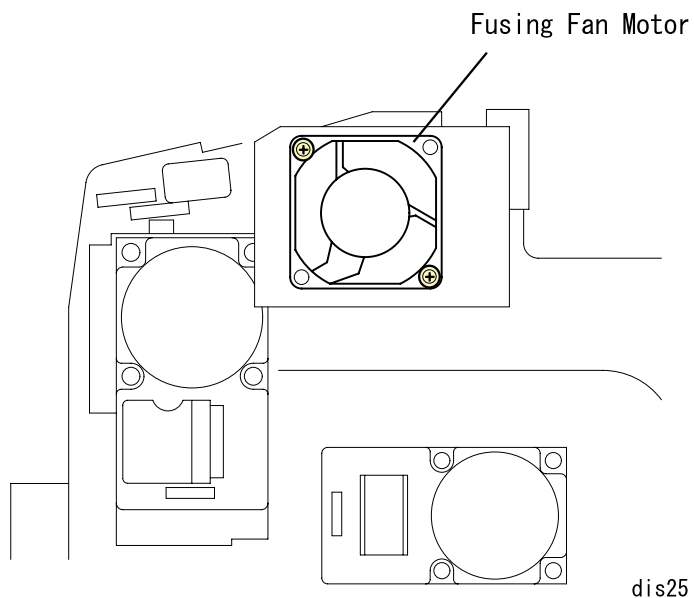

**Figure 4-28. Power Supply Cooling Fan Motor Removal**



### 4.2.11.2 Fusing Fan Motor Removal

1. Remove the Rear Controller Cover. (See "Rear Controller Cover Removal" on page -126.)
2. Free the fusing fan motor harness from 4 harness clamps.
3. Disconnect 1 fusing fan motor connector and remove 2 long screws securing the Fusing Fan Motor, and remove the Fusing Fan Motor.



**Figure 4-29. Fusing Fan Motor Removal**

### 4.2.11.3 Transfer Belt Fan Motor Removal

1. Remove the Rear Controller Cover. (See "Rear Controller Cover Removal" on page -126.)
2. Remove the Rear Right Cover. (See "Rear Right Cover Removal" on page -127.)
3. Remove the PU1 Support Board Removal. (See "PU1 Support Plate Removal" on page -135.)
4. Free the toner sucking fan harness from 4 harness clamps.
5. Disconnect the connector for the toner sucking fan and remove 2 long screws.

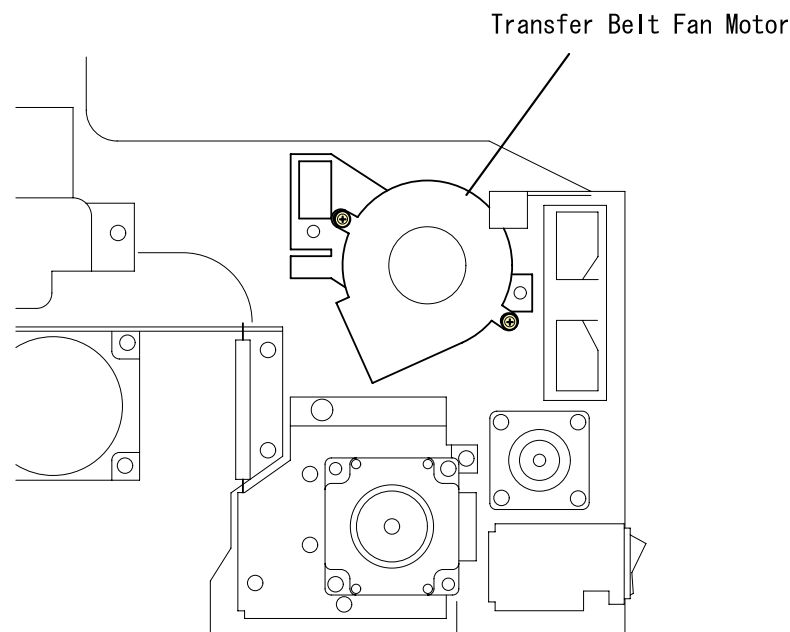

**Figure 4-30. Transfer Belt Fan Motor Removal**

#### 4.2.11.4 Cooling Fan Motor Removal

1. Remove the Rear Controller Cover. (See "Rear Controller Cover Removal" on page -126.)
2. Remove the Rear Cover. (See "Rear Cover Removal" on page -127.)
3. Remove the PU1 Support Board. (See "PU1 Support Plate Removal" on page -135.)
4. Remove the Controller Box. (See "Controller Box Removal" on page 131.)
5. Remove the HV1 (High Voltage Board). (See "HV1 (High Voltage Board) Removal" on page -133.)
6. Free the ozone fan harness from 2 harness clamps located under the PWB-A.
7. Disconnect the ozone fan harness and remove 2 screws.
8. Remove 2 long screws securing the ozone fan bracket.

Mechanism Cooling Fan Motor

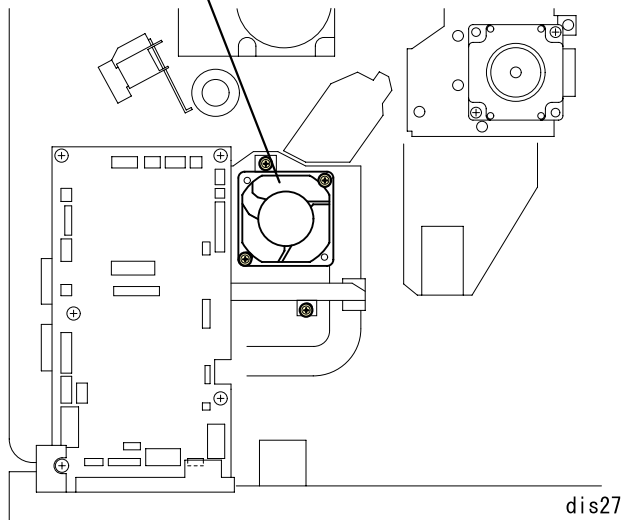
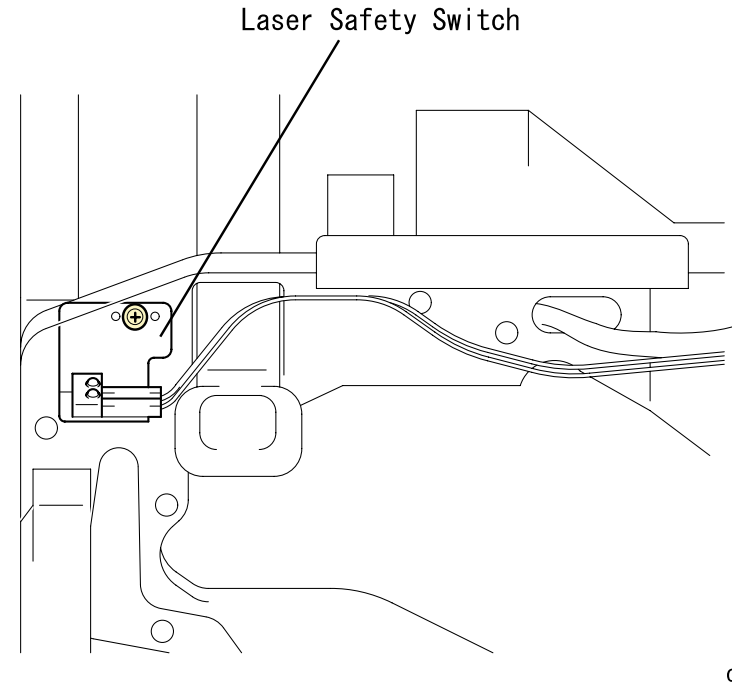

Figure 4-31. Cooling Fan Motor

#### 4.2.12 Laser Safety Switch (CDRH-SW) Removal

1. Remove the Front Inner Cover. (See "Front Inner Cover Removal" on page -124.)
2. Disconnect 2 connectors for the safety switch located at the top left of the Front Cover and remove 1 screw.



dis28

Figure 4-32. Laser Safety Switch (CDRH-SW) Removal

### 4.2.13 Waste Toner Full Sensor Removal

1. Remove the Front Cover. (See "Front Cover Removal" on page -123.)
2. Remove the Operation Panel. (See "Operation Panel Removal" on page -124.)
3. Remove the Front Inner Cover. (See "Front Inner Cover Removal" on page -124.)
4. Disconnect the harness for the Waste Toner Full Sensor from the connector.
5. Remove the Waste Toner Full Sensor.

Waste Toner Full Sensor

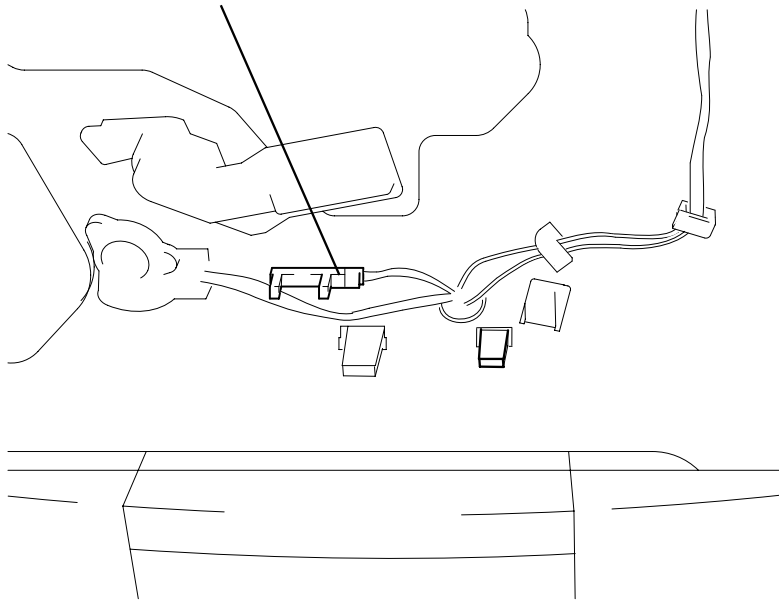

dis29

Figure 4-33. Waste Toner Full Sensor Removal

## 4.2.14 MP Tray Paper Load

### 4.2.14.1 Paper Load Cover Removal

1. Open the standard MP tray.
2. Remove 1 screw securing the Paper Load Cover.
3. Release 4 hooks securing the Paper Load Cover to the standard tray.

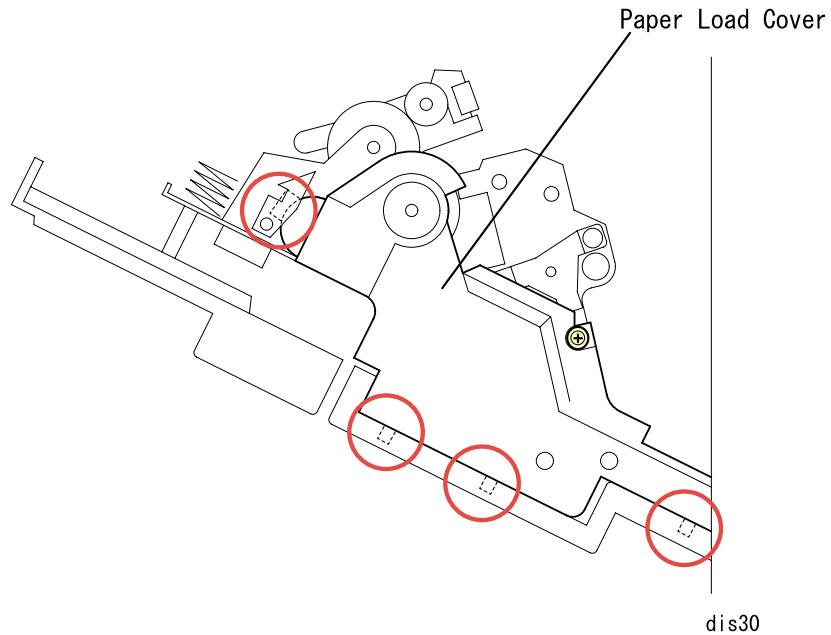

Figure 4-34. Paper Load Cover Removal

### 4.2.14.2 MP Tray Paper Load Solenoid Removal

1. Open the standard MP tray.
2. Remove the Paper Load Cover. (See "Paper Load Cover Removal" on page -140.)
3. Disconnect the harness for the MP Tray Paper Load Solenoid from the connector.
4. Remove 1 screw securing the MP Tray Paper Load Solenoid.

#### MP Tray Paper Load Solenoid

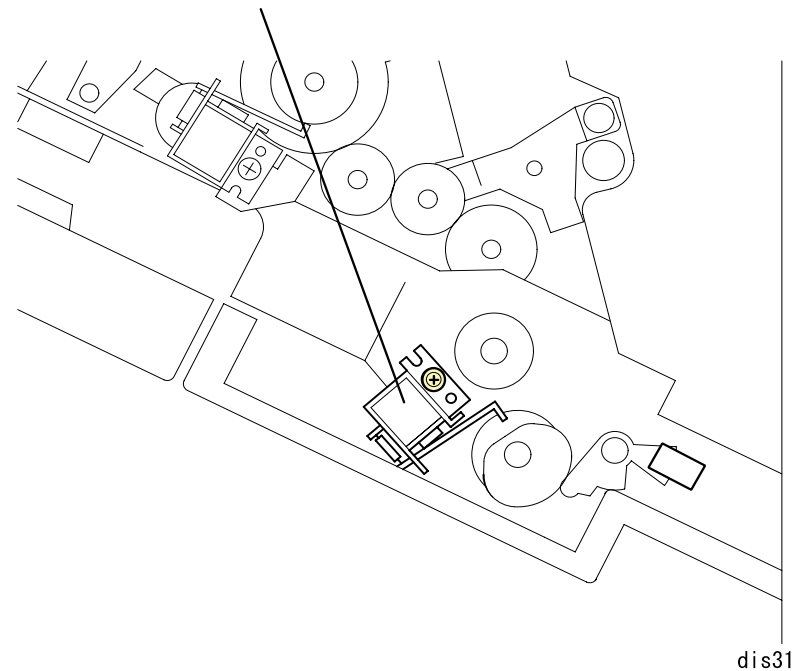
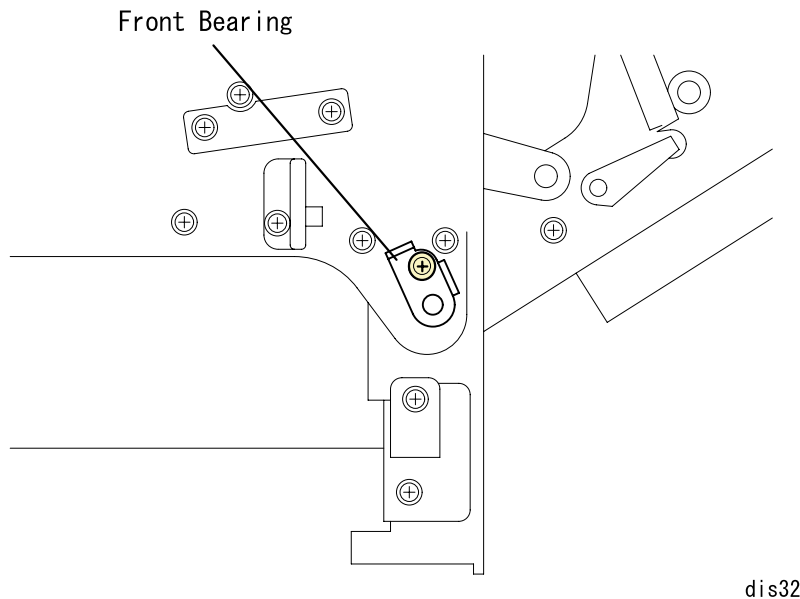

Figure 4-35. Manual Feed Tray Paper Load Solenoid Removal

## 4.2.15 MP Tray Paper Load Unit

### 4.2.15.1 Front Bearing for the MP Tray Paper Load Unit Removal

1. Remove the Front Cover. (See "Front Cover Removal" on page -123.)
2. Remove the Front Inner Cover. (See "Front Inner Cover Removal" on page -124.)
3. Remove 1 screw securing the Front Bearing.
4. Remove the Front Bearing for the MP Tray Paper Load Unit.



dis32

Figure 4-36. Front Bearing for the MP Tray Paper Load Unit

### 4.2.15.2 MP Tray Paper Load Unit Removal

1. Remove the Rear Controller Cover. (See "Rear Controller Cover Removal" on page -126.)
2. Remove the Rear Cover. (See "Rear Cover Removal" on page -127.)
3. Remove the Front Bearing. (See "Front Bearing for the MP Tray Paper Load Unit Removal" on page -141.)
4. Remove 1 screw securing the rear bearing.
5. Disconnect the harness for the MP Tray Paper Load Unit from the connector on the MCU.
6. Watching out for the spring, remove the front and rear bearing, and remove the MP Tray Paper Load Unit.

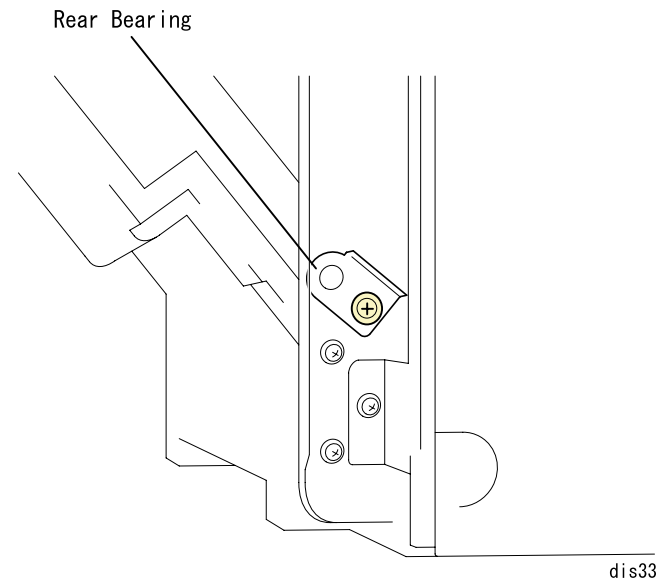

dis33

Figure 4-37. MP Tray Paper Load Unit Removal

## 4.2.16 Paper Cassette

### 4.2.16.1 Paper Size Switch Removal

**NOTE:** If the optional 500 Sheet Paper Cassette Unit is installed, remove it.

1. Prepare the thick buffer and lay the printer there on its left side down.
2. Release the fixing tab for the Paper Size Switch.
3. Disconnect the harness from the connector on the sensor.

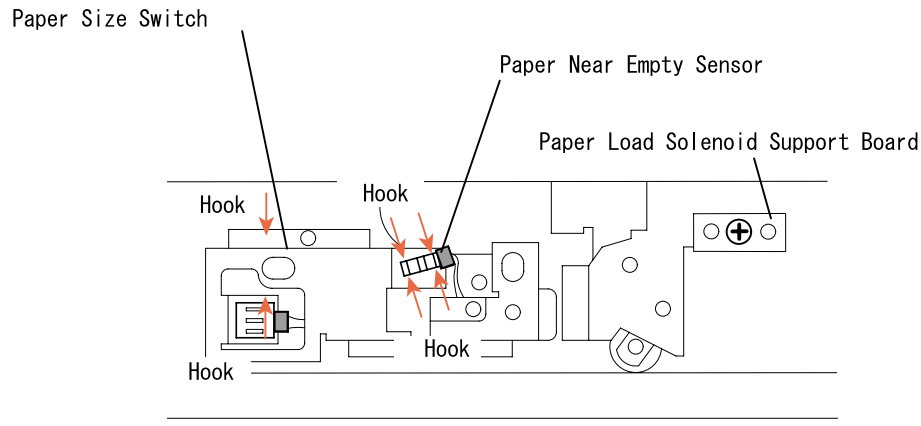

dis34

**Figure 4-38.**

**Paper Size Switch / Paper Near Empty Sensor Removal**

### 4.2.16.2 Paper Near Empty Sensor Removal

1. Prepare the thick buffer and lay the printer there on its left side down.
2. Release the fixing tab for the Paper Near Empty Sensor.
3. Remove the harness from the connector on the sensor.

### 4.2.16.3 Cassette Paper Load Solenoid Removal

1. Remove the Rear Controller Cover. (See "Rear Controller Cover Removal" on page -126.)
2. Remove the Rear Cover. (See "Rear Cover Removal" on page -127.)
3. Remove the PWB-B Support Plate. (See "HV2 (High Voltage Board) Removal" on page -133.)
4. Remove the MP Tray Paper Load Unit. (See "MP Tray Paper Load Unit Removal" on page -141.)
5. Remove 1 screw securing the support plate and remove the Paper Load Solenoid. (See Figure 4-38, "Paper Size Switch / Paper Near Empty Sensor Removal")

## 4.2.17 Transfer Mechanism

### 4.2.17.1 Timing Roller Solenoid Removal

1. Remove the Rear Controller Cover. (See "Rear Controller Cover Removal" on page -126.)
2. Remove the Rear Cover. (See "Rear Cover Removal" on page -127.)
3. Remove the PU1 Support Plate. (See "PU1 Support Plate Removal" on page -135.)
4. Remove the harness of the Timing Roller Solenoid from the MCU connector.
5. Remove 1 screw securing the Timing Roller Solenoid to the main frame.

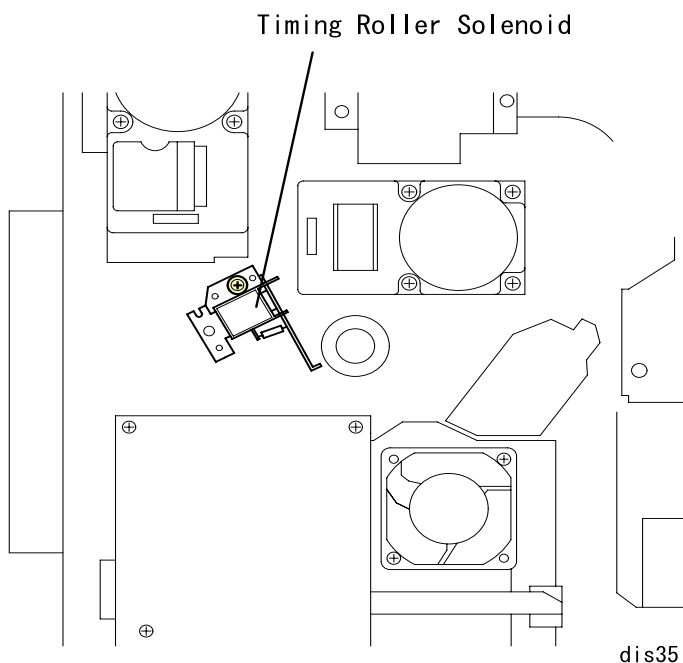

Figure 4-39. Timing Roller Solenoid Removal

### 4.2.17.2 Middle Roller Solenoid Removal

1. Remove the Rear Controller Cover. (See "Rear Controller Cover Removal" on page -126.)
2. Remove the Rear Cover. (See "Rear Cover Removal" on page -127.)
3. Remove the PWB-A Support Plate. (See "MCU (PWB-A Board) Removal" on page -131.)
4. Remove the connector of the Middle Roller Solenoid and 1 screw.

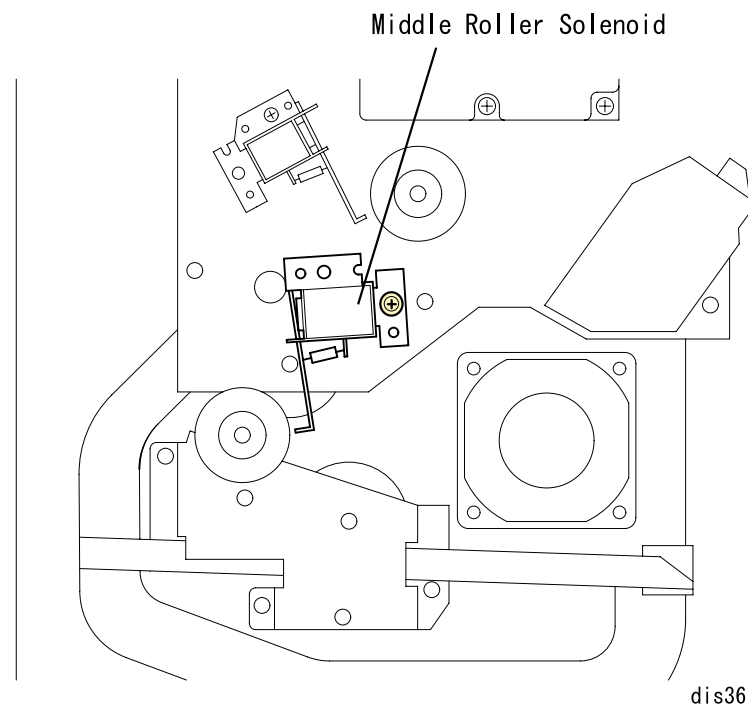
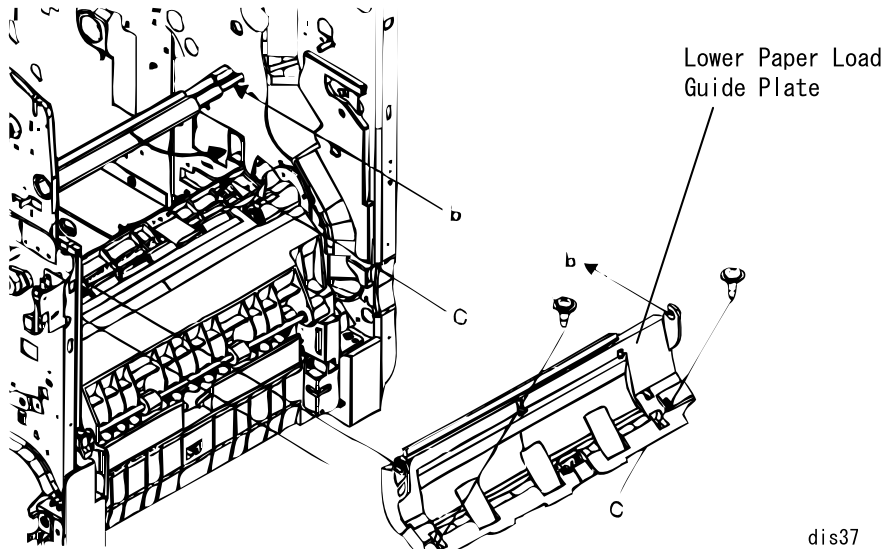

Figure 4-40. Middle Roller Solenoid Removal

### 4.2.17.3 Lower Paper Load Guide Removal

1. Lift the bottom end (green part) of the Upper Paper Load Guide and release the hook of Timing Roller.
2. Remove 2 screws securing the Lower Paper Load Guide.
3. Lift the bottom end of the Bottom Paper Load Guide and release the hook of Timing Roller.



dis37

Figure 4-41. Lower Paper Load Guide Removal

### 4.2.17.4 Timing Sensor Removal

1. Remove the Lower Paper Load Guide. (See "Lower Paper Load Guide Removal" on page -144.)
2. Release the hook securing the Timing Sensor to the Lower Paper Load Guide.

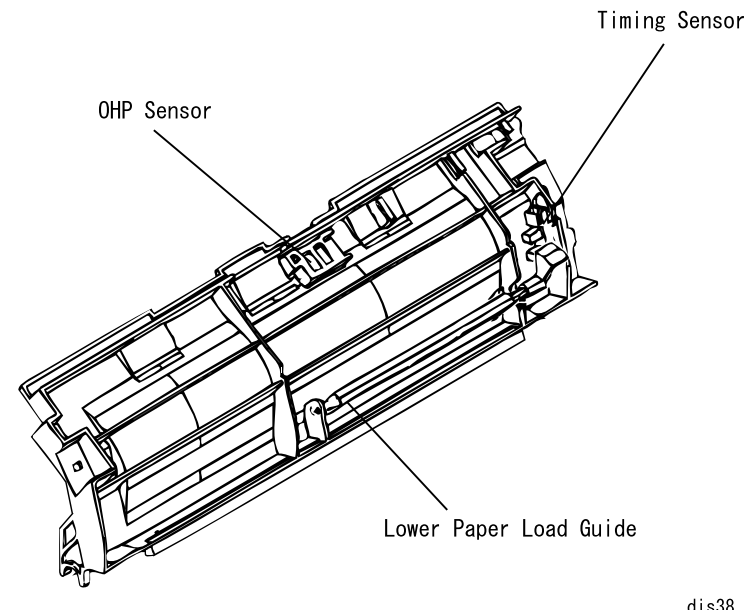

dis38

Figure 4-42. Timing Sensor Removal

### 4.2.18 OHP Sensor Removal

1. Remove the Lower Paper Load Guide. (See "Lower Paper Load Guide Removal" on page -144.)
2. Release the hook securing the OHP Sensor to the Lower Paper Load Guide. (See Figure 4-42. "Timing Sensor Removal" on page -144.)



## 4.2.19 Developer Mechanism

### 4.2.19.1 Toner Empty Sensor Removal

1. Remove the Front Cover. (See "Front Cover Removal" on page -123.)
2. Remove the Front Inner Cover. (See "Front Inner Cover Removal" on page -124.)
3. Remove the connector of the Toner Empty Sensor.
4. Remove 2 screws securing the Toner Empty Sensor to the main frame.

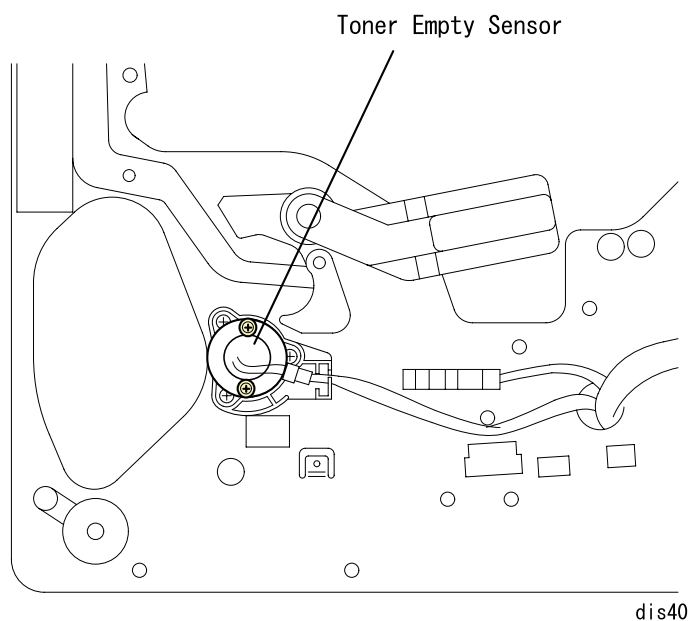

**Figure 4-43. Toner Empty Sensor Removal**

### 4.2.19.2 Front Side Rack Bearing Removal

1. Remove the Toner Empty Sensor.
2. Remove 3 screws securing the Front Side Rack Bearing.

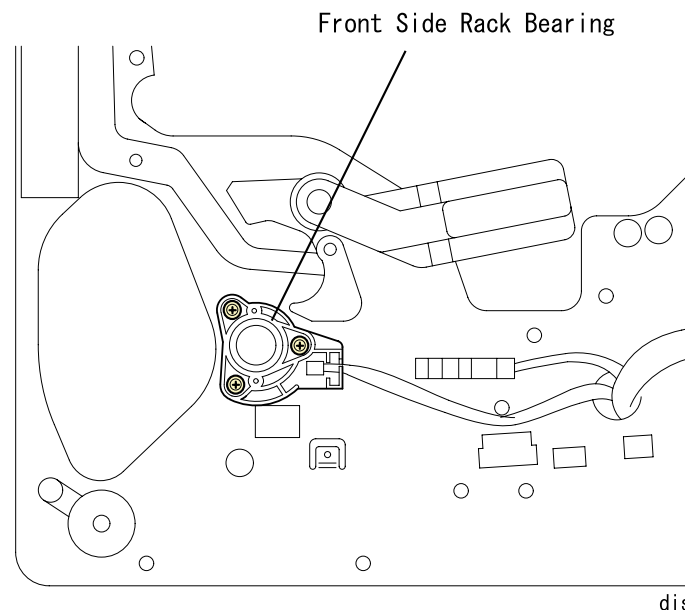

**Figure 4-44. Front Side Rack Bearing Removal**

### 4.2.19.3 Rack Lock Lever Removal

1. Remove the Rear Controller Cover. (See "Rear Controller Cover Removal" on page -126.)
2. Remove the Rear Cover. (See "Rear Cover Removal" on page -127.)
3. Remove the Controller Box. (See "Controller Box Removal" on page 131.)
4. Remove the Left Cover. (See "Left Cover Removal" on page -125.)
5. Remove 2 screws securing the Rack Lock Lever to the main frame.

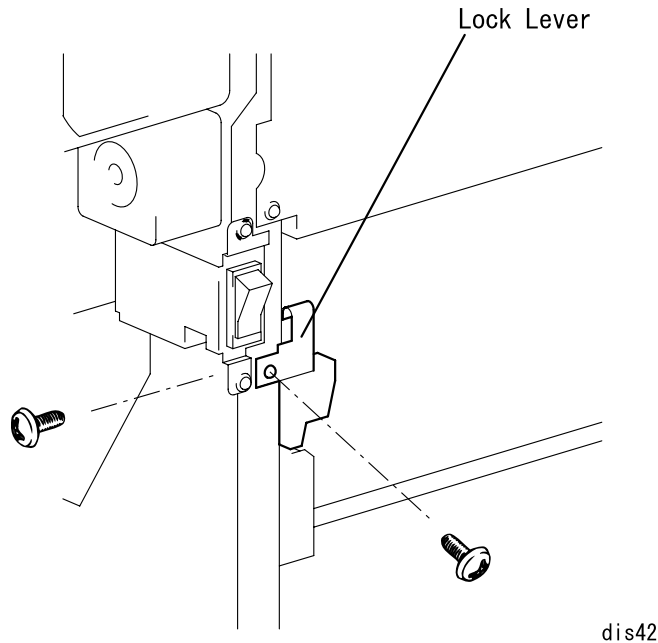

**Figure 4-45. Rack Lock Lever Removal**

### 4.2.19.4 Rack Black Position Sensor Removal

1. Remove the Rear Controller Cover. (See "Rear Controller Cover Removal" on page -126.)
2. Remove the Rear Cover. (See "Rear Cover Removal" on page -127.)
3. Remove the HV1 (High Voltage Board). (See "HV1 (High Voltage Board) Removal" on page -133.)
4. Remove 1 screw securing the Rack Black Position Sensor and 1 connector.

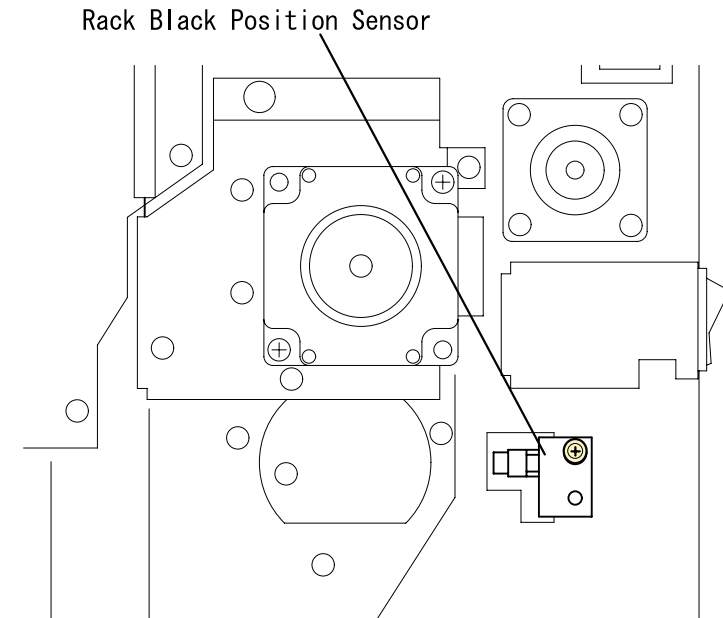

**Figure 4-46. Rack Black Position Sensor Removal**

#### 4.2.19.5 Developer Motor Assy. Removal

1. Remove the Rear Controller Cover. (See "Rear Controller Cover Removal" on page -126.)
2. Remove the Rear Cover. (See "Rear Cover Removal" on page -127.)
3. Remove the PU1 Support Plate. (See "PU1 Support Plate Removal" on page -135.)
4. Remove 1 Tension Spring installed on the installation plate of Developer Motor Assy. and Transfer Motor.
5. Remove the harness from 4 harness cramps of Developer Motor Installation Plate.
6. Remove 4 screws securing Developer Motor Assy. and 1 harness.

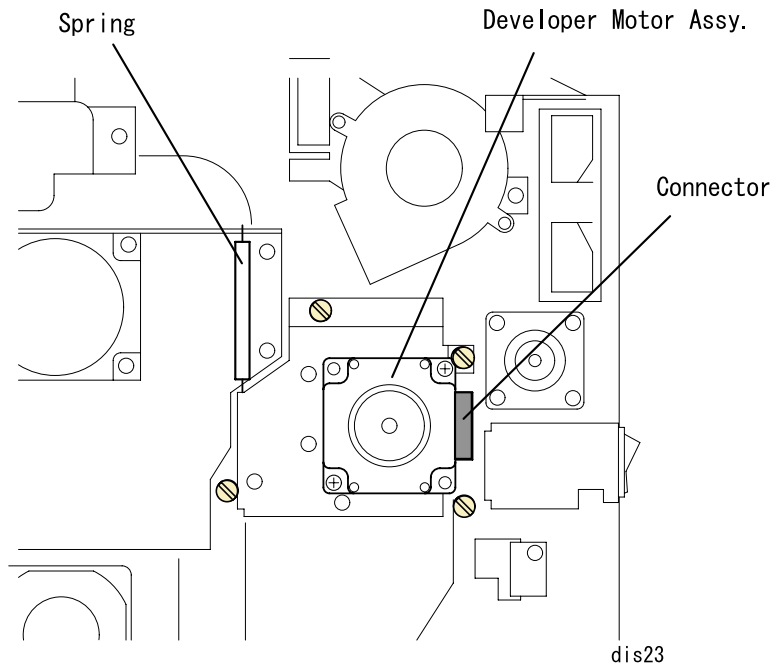

Figure 4-47. Developer Motor Assy. Removal

#### 4.2.19.6 Rear Rack Bearing Removal

1. Remove the Rear Controller Cover. (See "Rear Controller Cover Removal" on page -126.)
2. Remove the Rear Cover. (See "Rear Cover Removal" on page -127.)
3. Remove the PU1 Support Plate. (See "PU1 Support Plate Removal" on page -135.)
4. Remove Developer Motor Assy. (See "Developer Motor Assy. Removal" on page -147.)
5. Remove 3 connectors of Rear Rack Bearing and 4 screws.
6. Slowly pull Front Bearing and remove it.

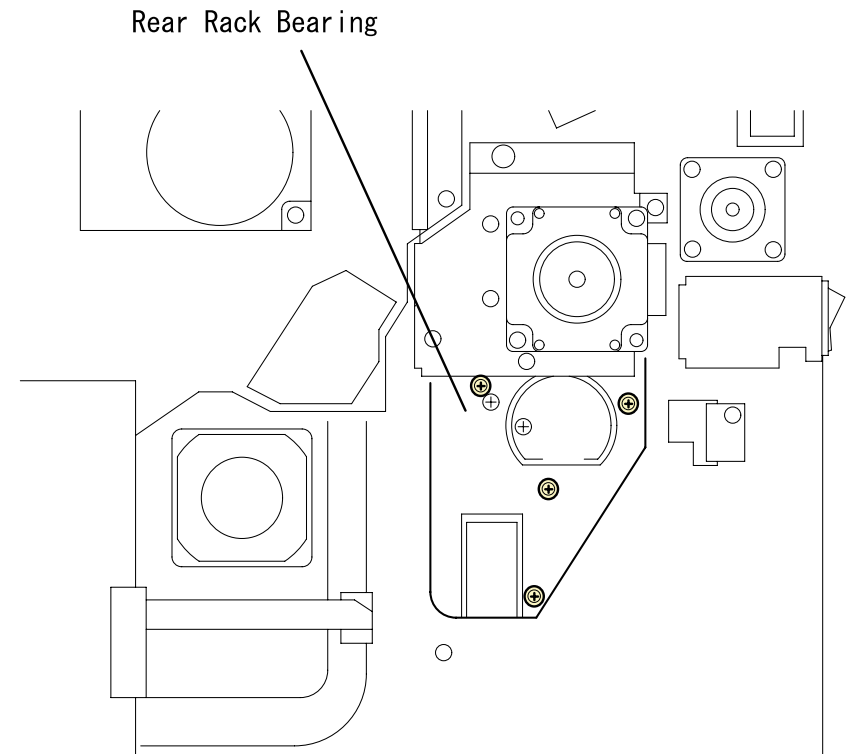
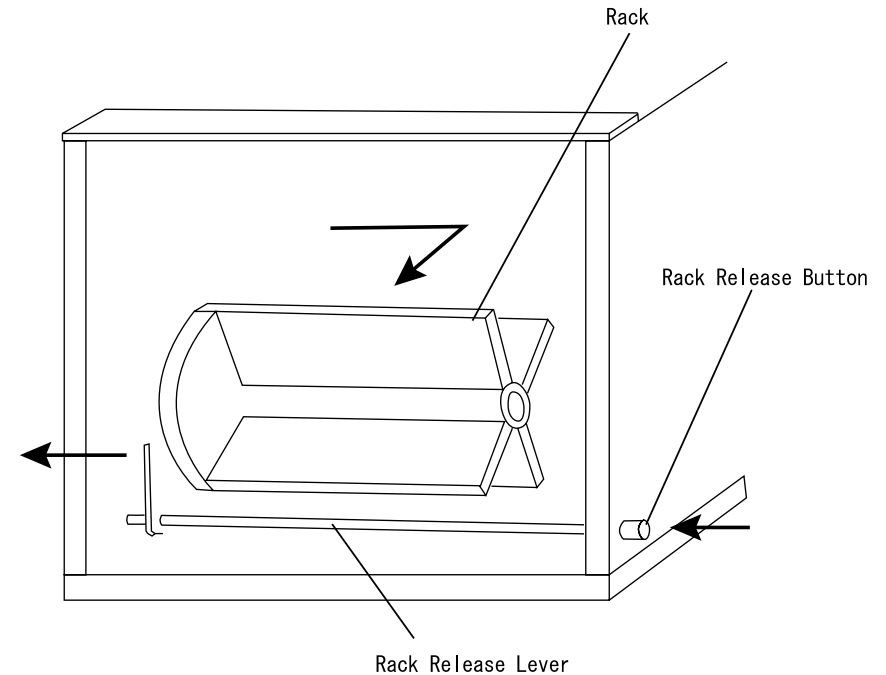

Figure 4-48. Rear Rack Bearing Removal

#### 4.2.19.7 Rack Removal

1. Remove the Rear Controller Cover. (See "Rear Controller Cover Removal" on page -126.)
2. Remove the Rear Cover. (See "Rear Cover Removal" on page -127.)
3. Remove the PU1 Support Plate. (See "PU1 Support Plate Removal" on page -135.)
4. Remove the Developer Motor Assy. (See "Developer Motor Assy. Removal" on page -147.)
5. Remove the Left Frame Plate. (See "Left Frame Plate Removal" on page -153.)
6. Remove the Toner Empty Sensor. (See "Rear Cover Removal" on page -127.)
7. Remove the Front Side Rack Bearing. (See "Front Side Rack Bearing Removal" on page -145.)
8. Remove the Rack Lock Lever. (See "Rack Lock Lever Removal" on page -146.)
9. Remove the Rack Black Position Sensor. (See "Rack Black Position Sensor Removal" on page -146.)
10. Remove the Developer Motor Assy. (See "Developer Motor Assy. Removal" on page -147.)
11. Remove the Rear Rack Bearing. (See "Rear Rack Bearing Removal" on page -147.)
12. Press the rack release button from the front side. (You can also release the E ring of the Rack Release Lever to release the Lever.)
13. Pull the Rack to the front and remove it. Be careful not to hang the rear end.



**Figure 4-49. Rack Removal**

## 4.2.20 PH (Print Head) Mechanism

### 4.2.20.1 PH Connector Removal

1. Remove the Rear Controller Cover. (See "Rear Controller Cover Removal" on page -126.)
2. Remove the Rear Cover. (See "Rear Cover Removal" on page -127.)
3. Remove 2 PH connectors from MCU (PWB-A) Board.
4. Remove PH harness from the harness duct.

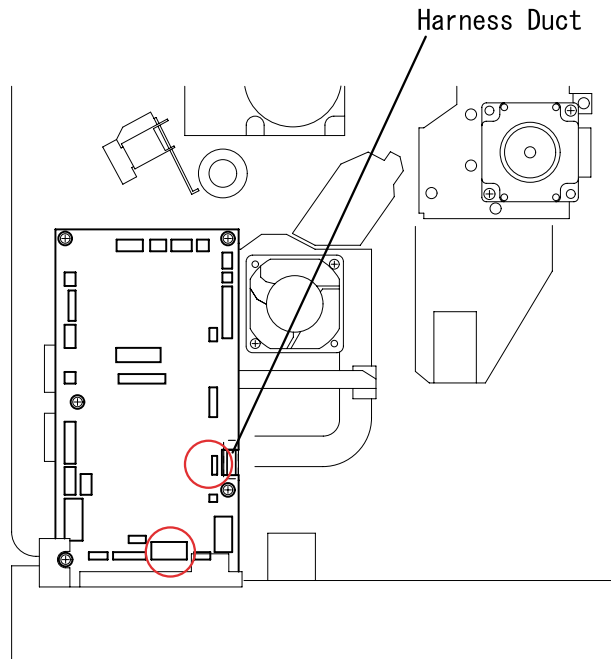

Figure 4-50. PH Connector Removal

### 4.2.20.2 PH Cover Removal

1. Remove the Rear Controller Cover. (See "Rear Controller Cover Removal" on page -126.)
2. Remove the Rear Cover. (See "Rear Cover Removal" on page -127.)
3. Remove 2 PH connectors from MCU (PWB-A) Board.
4. Remove the PH harness from the harness duct.

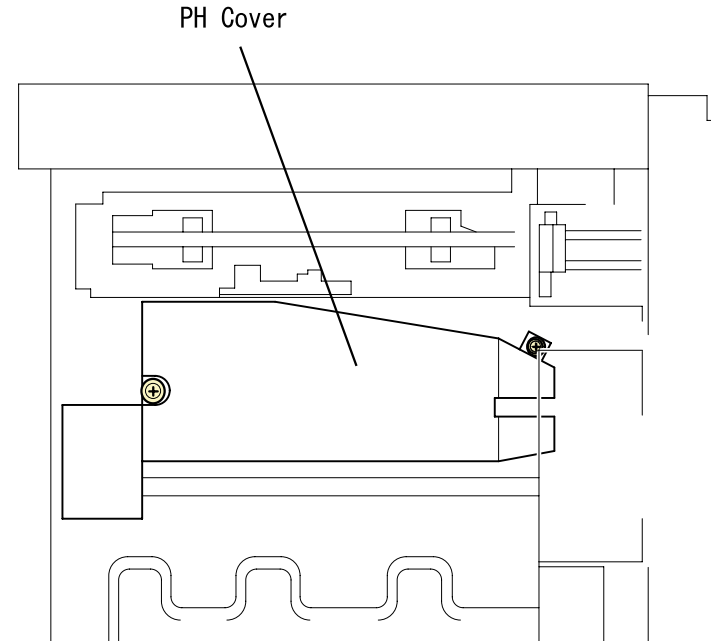

Figure 4-51. PH Cover Removal

### 4.2.20.3 PH Removal

1. Remove the PH connector. (See "PH Connector Removal" on page -149.)
2. Remove 4 screws securing PH.



**Never conduct electricity with PH removed. It will emit invisible laser light and it may result in losing the eyesight.**

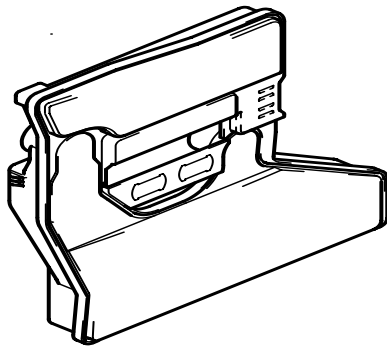

Figure 4-52. PH Removal

### 4.2.21 Transfer Mechanism

#### 4.2.21.1 Transfer Roller Pressure Solenoid Removal

1. Remove the Paper Load Cover. (See "Paper Load Cover Removal" on page -140.)
2. Remove the harness of the transfer roller pressure solenoid from the connector.
3. Remove 1 screw securing the transfer roller pressure solenoid.

Transfer Roller Pressure Solenoid

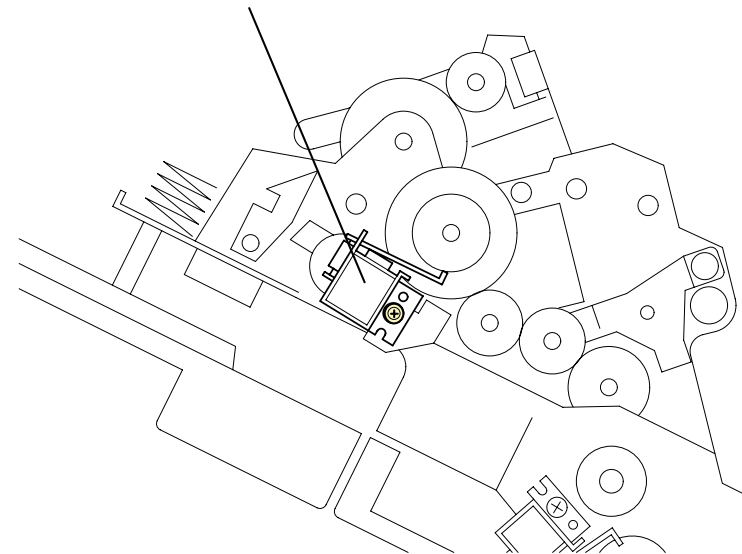
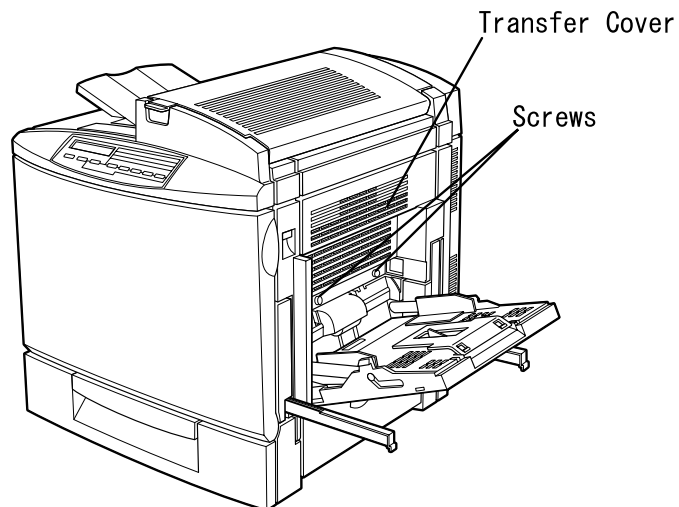

Figure 4-53. Transfer Roller Pressure Solenoid Removal

### 4.2.21.2 Transfer Roller Pressure Sensor Removal

1. Open the standard tray.
2. Remove the fusing cover and duplex unit if installed.



**Figure 4-54. Transfer Cover**

3. Remove the hook of the transfer roller pressure sensor.
4. Remove the harness from the sensor connector.

Transfer Roller Pressure Sensor

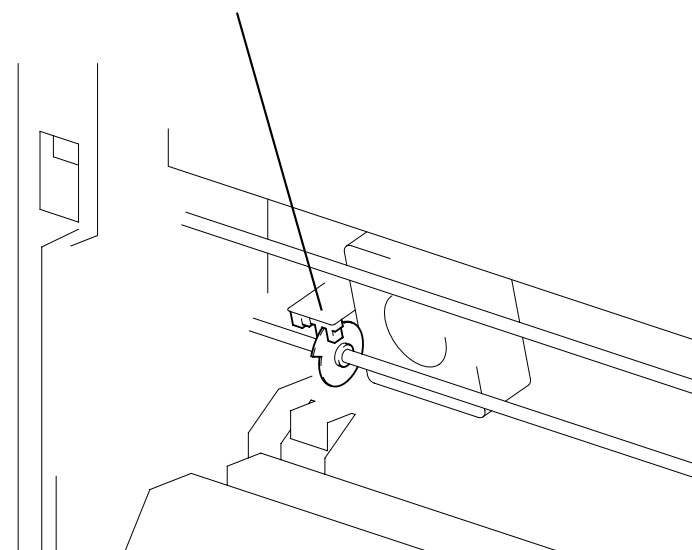

**Figure 4-55. Transfer Roller Pressure Sensor**

#### 4.2.21.3 Suction Fan Motor Removal

1. Open the standard tray.
2. Remove the transfer cover and duplex unit if installed. (2 screws) (See "Transfer Roller Pressure Sensor Removal" on page -151.)
3. Remove the harness of the Suction Fan from the Harness Saddle, which secures the harness to the Standard Tray at 3 points.
4. Remove 2 long screws securing the suction fan.

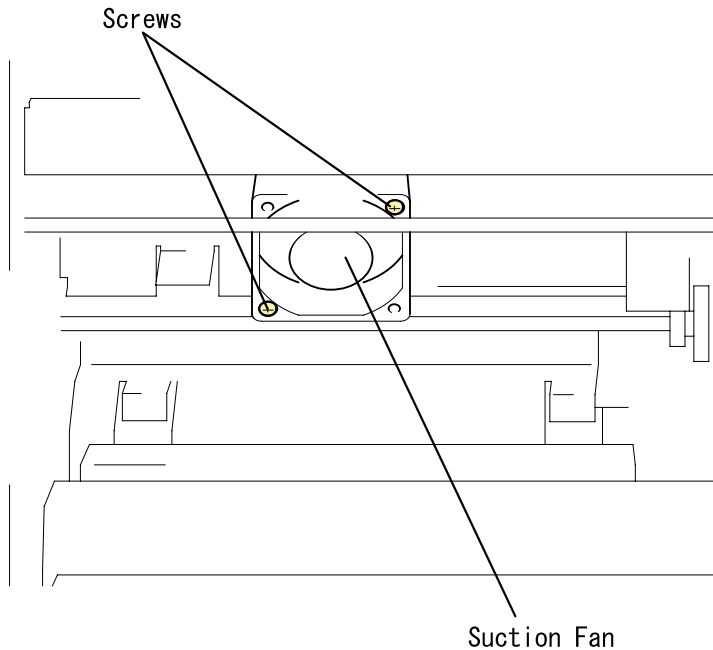

**Figure 4-56. Suction Fan Motor Removal**

#### 4.2.21.4 Middle Paper Sensor Removal

1. Remove the suction fan. (See "Suction Fan Motor Removal" on page -152.)
2. Remove the harness from the middle paper sensor connector.
3. Remove 1 screw securing the middle paper sensor.

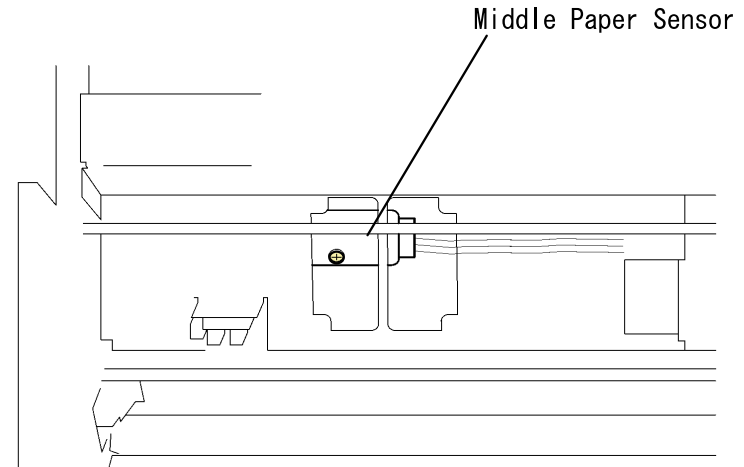

**Figure 4-57. Middle Paper Sensor Removal**



## 4.2.22 Belt Cleaner Mechanism

### 4.2.22.1 Left Upper Support Plate Removal

1. Remove the Operation Panel. (See "Operation Panel Removal" on page -124.)
2. Remove the Front Inner Cover. (See "Front Inner Cover Removal" on page -124.)
3. Remove the Top Cover. (See "Top Cover Removal" on page -125.)
4. Remove the Left Cover. (See "Left Cover Removal" on page -125.)
5. Remove the Rear Controller Cover. (See "Rear Controller Cover Removal" on page -126.)
6. Remove the Rear Cover. (See "Rear Cover Removal" on page -127.)
7. Remove 5 screws securing the left upper support plate. (Upper side: 3 screws, Front rear side: 1 screw each)

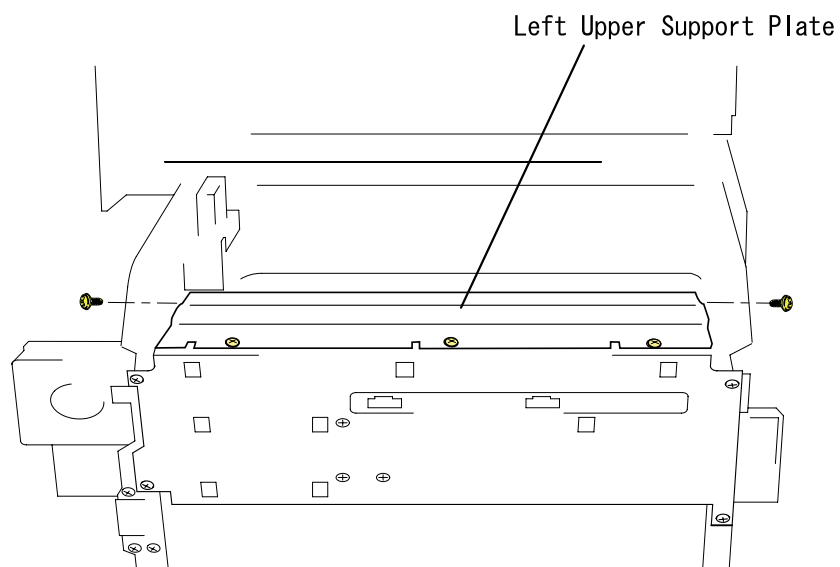

Figure 4-58. Left Upper Support Plate Removal

### 4.2.22.2 Left Frame Plate Removal

1. Remove the Left Upper Support Plate. (See "Left Upper Support Plate Removal" on page -153.)
2. Remove the harness from the harness saddle at the left frame.
3. Remove 4 screws securing the left frame plate.
4. Remove the harnesses from 4 connectors of the belt cleaner control board on the left frame.

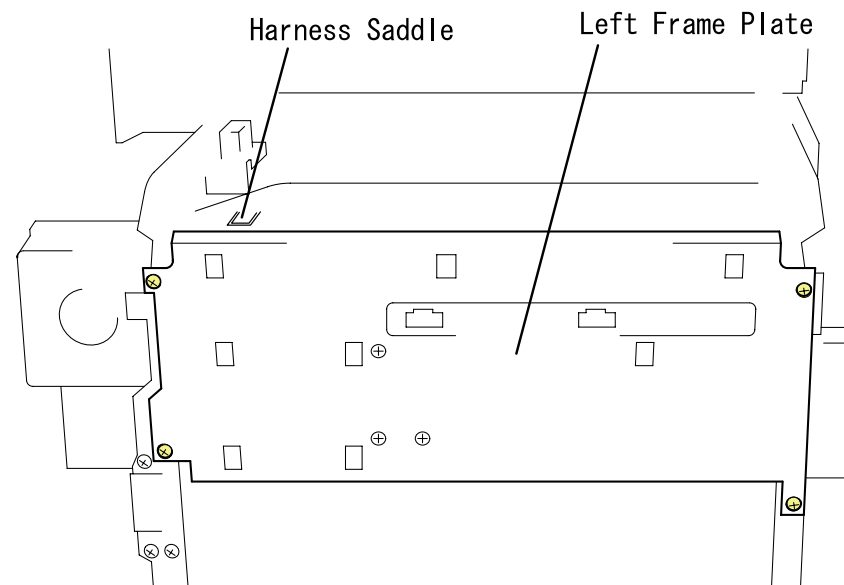

Figure 4-59. Left Frame Plate Removal

#### 4.2.22.3 Belt Cleaner Estrangement Position Sensor Removal

1. Remove the Left Frame Plate. (See "Left Frame Plate Removal" on page -153.)
2. Release the hook of the belt cleaner estrangement position sensor.

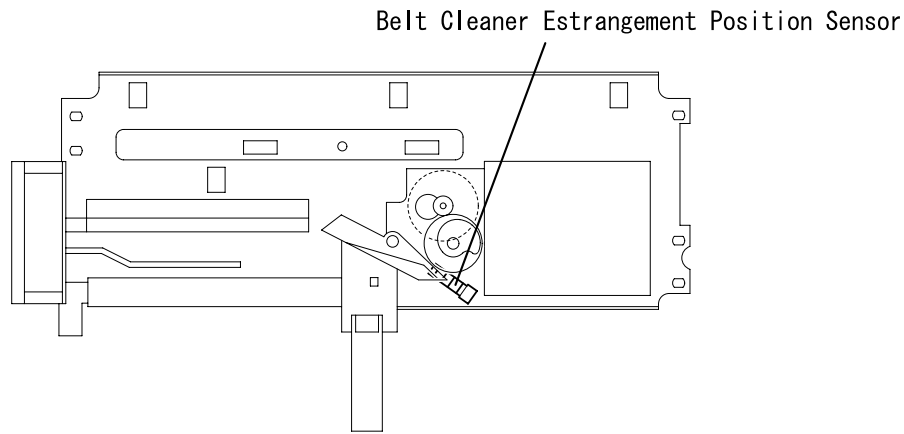

Figure 4-60. Belt Cleaner Estrangement Position Sensor Removal

#### 4.2.22.4 PWB-I (Belt Cleaner Control Board) Removal

1. Remove the Left Frame Plate. (See "Left Frame Plate Removal" on page -153.)
2. Remove 4 screws securing the PWB-I (Belt Cleaner Control Board).

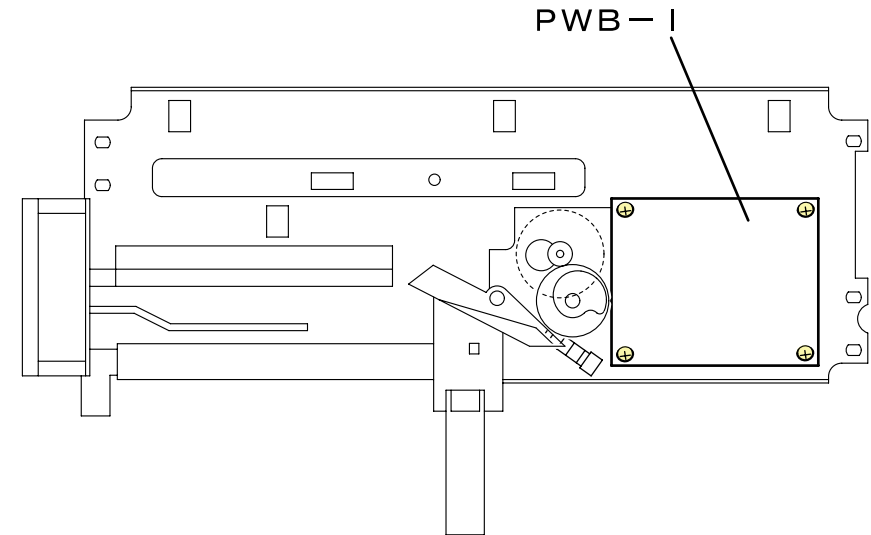

Figure 4-61. PWB-I (Belt Cleaner Control Board) Removal

## 4.2.23 Fusing Mechanism

### 4.2.23.1 Pressure Roller Estrangement Sensor Removal

1. Remove the Fusing Pressure Motor. (See "Fusing Pressure Motor Removal" on page -136.)
2. Remove 1 screw and 1 connector of the pressure roller estrangement sensor.

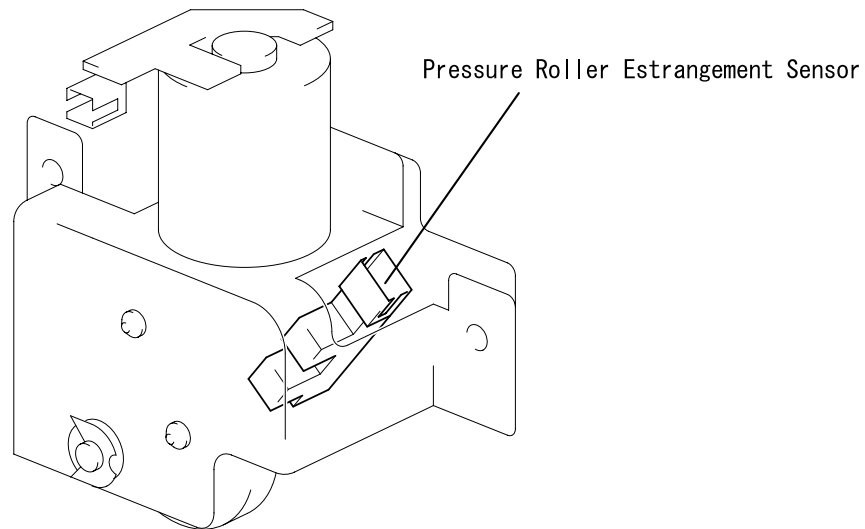

Figure 4-62. Pressure Roller Estrangement Sensor Removal

## 4.2.24 Paper Eject Mechanism

### 4.2.24.1 Paper Eject Sensor Removal

1. Open the fusing cover.
2. Remove 4 screws securing the sensor support plate.
3. Remove 1 connector securing the paper eject sensor.
4. Release the paper eject sensor hook.

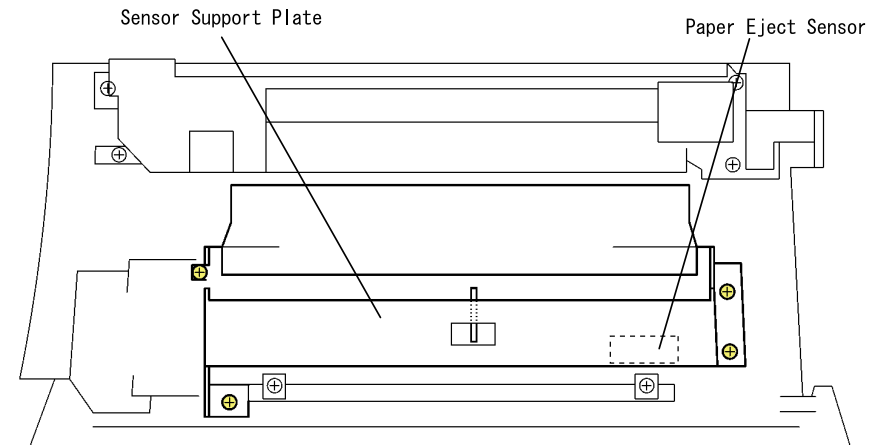

Figure 4-63. Paper Eject Sensor Removal

## 4.2.25 Rack Motor Assy.

### 4.2.25.1 Power Switch Removal

1. Remove the Rear Controller Cover. (See "Rear Controller Cover Removal" on page -126.)
2. Remove the Rear Cover. (See "Rear Cover Removal" on page -127.)
3. Remove the Rear Right Cover. (See "Rear Right Cover Removal" on page -127.)
4. Remove 2 screws securing the Power Switch.

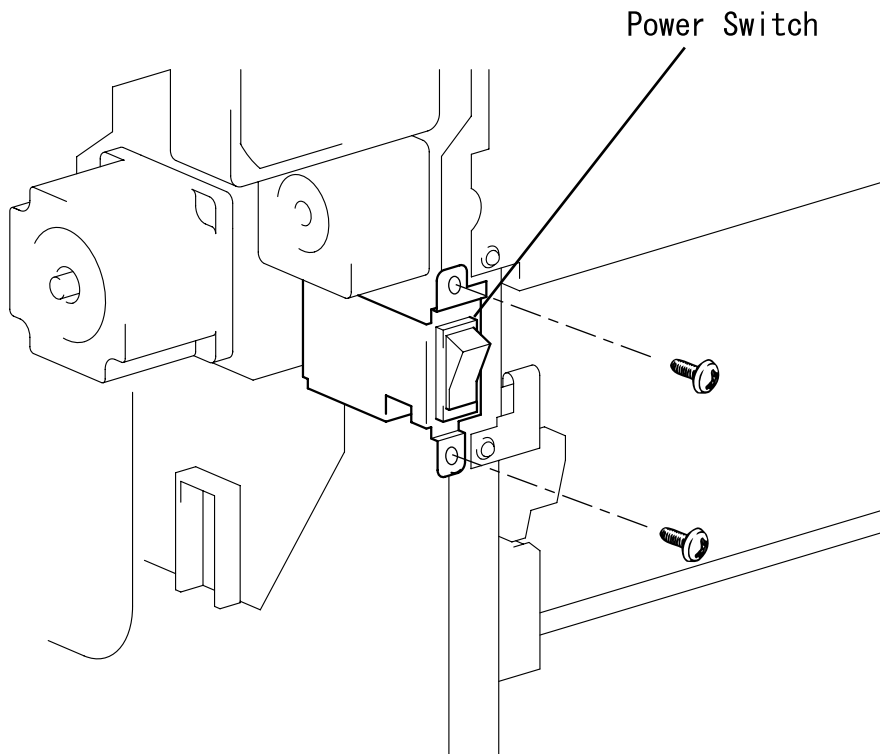

Figure 4-64. Power Switch

### 4.2.25.2 Rack Motor Assy. Removal

1. Remove 2 screws securing the power fan installation plate to the printer and remove the power fan.
2. Remove the power switch. (See "Power Switch Removal" on page -156.)
3. Remove 1 connector and 2 screws of Rack Motor Assy.
4. Remove Rack Motor Assy.

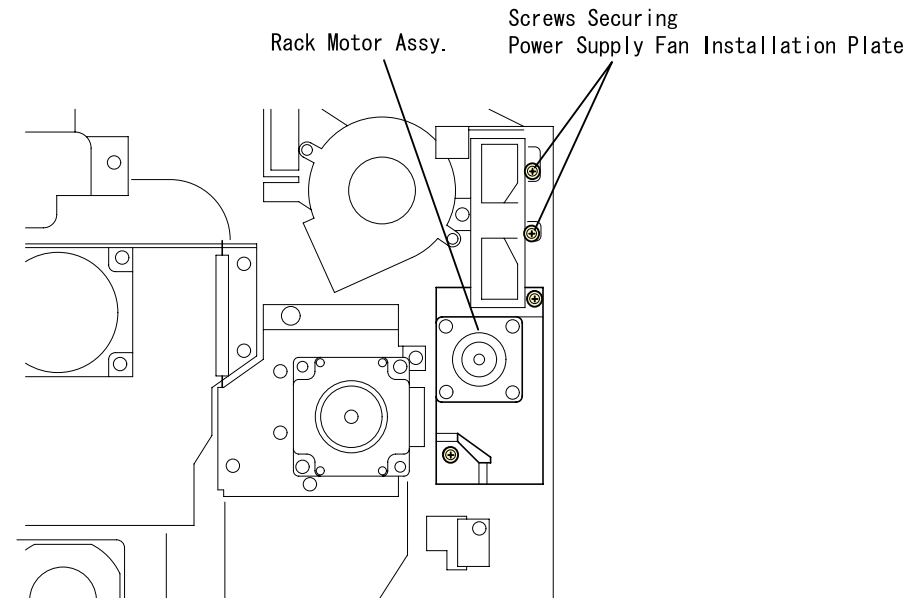

Figure 4-65. Rack Motor Assy. Removal

## 4.2.26 Duplex Unit

### 4.2.26.1 Duplex Paper Feed Sensor Removal

1. Remove 2 screws securing the Duplex Unit to the printer.
2. Remove the sensor cover.
3. Release the hook of the Duplex Paper Feed Sensor.

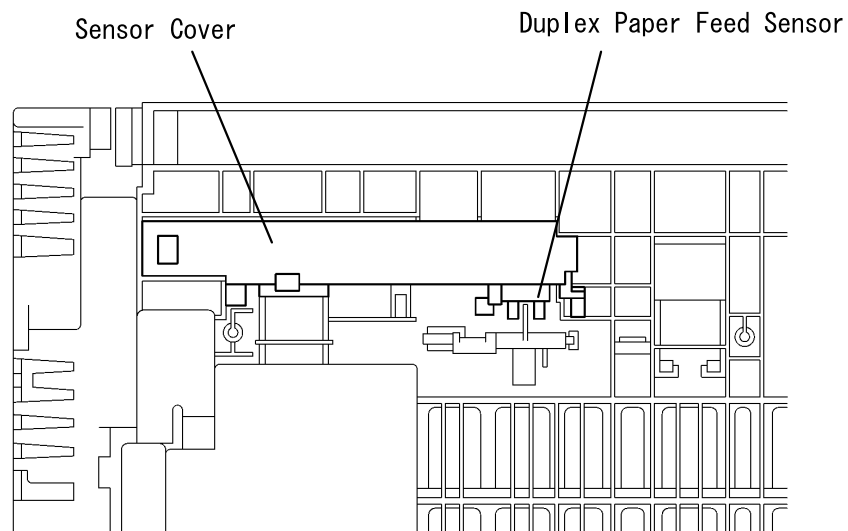

Figure 4-66. Duplex Paper Feed Sensor Removal

### 4.2.26.2 Duplex Unit Board Cover Removal

1. Remove 1 screw securing the board cover to the duplex unit.

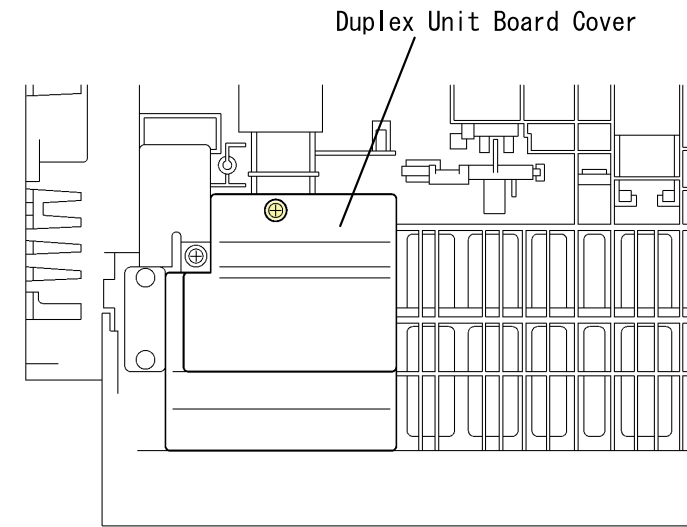

Figure 4-67. Duplex Unit Board Cover Removal

#### 4.2.26.3 Duplex Unit Board (PWB-AD) Removal

1. Remove the Board Cover. (See "Duplex Unit Board Cover Removal" on page -157.)
2. Remove the harness from 3 connectors on the Duplex Unit Board (PWB-AD).
3. Remove 2 screws securing the Duplex Unit Board (PWB-A).

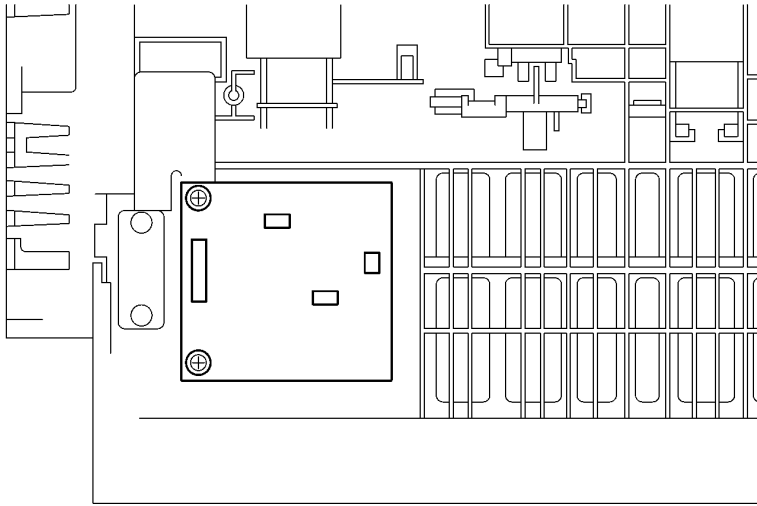

Figure 4-68. Duplex Unit Board (PWB-AD) Removal

#### 4.2.26.4 Motor Cover Removal

1. Remove 1 screw securing the Motor Cover.
2. Release 1 hook securing the Motor Cover to the Duplex Unit.

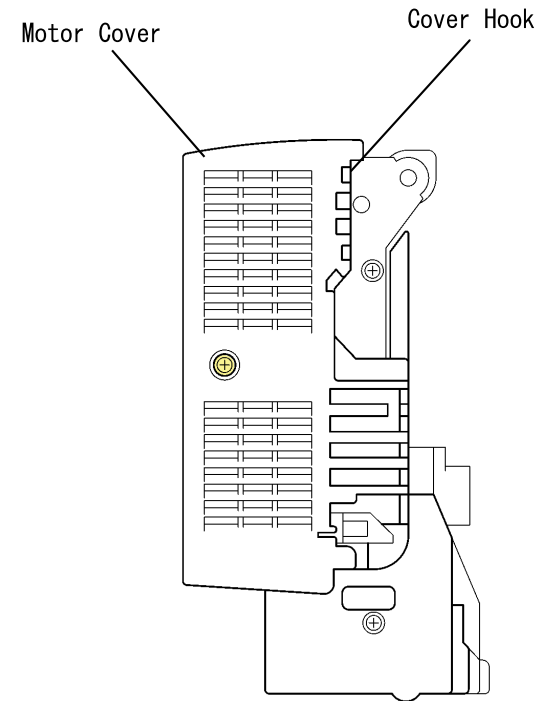

Figure 4-69. Motor Cover

#### 4.2.26.5 Motor Plate Removal

1. Remove 2 motor connectors from the Motor Plate and 3 screws securing the Plate.

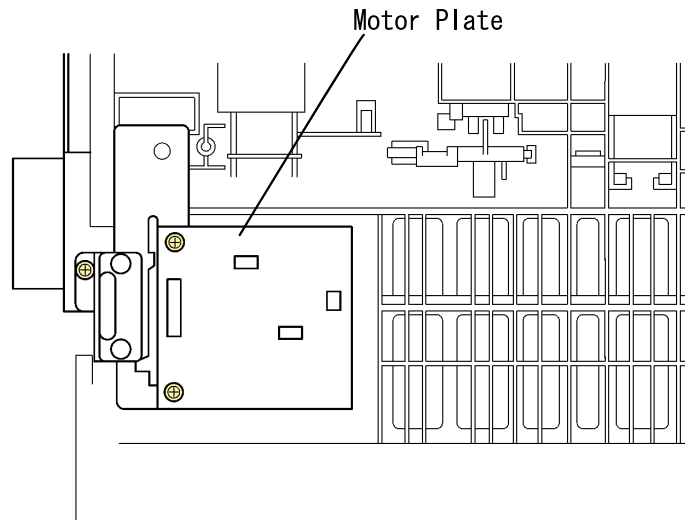

Figure 4-70. Motor Plate Removal

#### 4.2.26.6 Reverse Motor Removal

1. Remove 3 screw securing the Motor Plate.
2. Remove the harness from 3 harness saddles.
3. Remove 2 screws securing the Switch Back Motor.

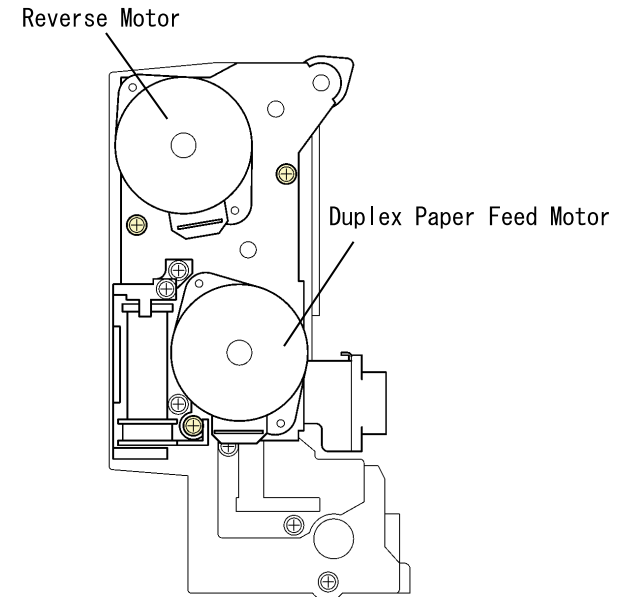

Figure 4-71. Reverse Motor / Duplex Paper Load Motor

#### 4.2.26.7 Duplex Paper Load Motor Removal

1. Remove 3 screw securing the Motor Plate.
2. Remove the harness from 3 harness saddles.
3. Remove 2 screws securing the Duplex Paper Load Motor. (See Figure 4-71. "Reverse Motor / Duplex Paper Load Motor" on page -159.)

## 4.3 Program ROM Update

The firmware of this printer is stored on the Flash-ROM DIMM (program ROM) on the controller circuit board (C314MAIN). There are 2 ways to update firmware. (See "Control Panel" on page -37.)

### 4.3.1 Program ROM Update

This section explains the method of downloading the firmware form the parallel interface.

1. Store the firmware (\*.crb) to the arbitrary folder of HDD of PC in advance.
2. Connect the printer and PC via parallel interface cable.
3. Set this printer to the default by the Windows printer configuration. Set the printer port to LPT1: or the appropriate port.
4. On the panel, while pressing "On Line", "Alt" and "Value Selection Switch", turn the printer ON.

The printer displays "Program Device" > "Version \*.\*" > "Please Send Data" and the printer waits for the data coming.

**NOTE:** At this point, if you want to cancel updating, turn off the printer. If you turn off the printer, firmware remains as is.

5. Input the following command line to PC and transfer the new firmware.  
> copy \_ \*.crb \_ lpt1 [return]
6. When the printer displays "OLD: \*\*\*\* NEW: \*\*\*\*", press "Enter Switch".  
Display indicates "Erasing Device" > "Prig ..." and writing to DIMM will be started.

**NOTE:** At this point, if you want to cancel updating, press "Menu Selection Switch". Display indicates "WAIT\_RESET" and firmware remains as is.



After pressing the "Enter Switch", you cannot return to the former state of firmware.

7. When the display indicates "Checksum ROM Data", the transfer is completed. Turn off and on the printer or press the "Enter Switch" to reboot the printer. The printer becomes ready to print. Printer will operate with new firmware.

#### 4.3.1.1 Error Indication and Remedies

- <END: CMD Error: CONT>
  - Cause: Data of different model is transferred.  
After data transfer, the printer indicates this error before version check.
  - Remedy:  
When "Menu Selection Switch" is pressed, the printer indicates "WAIT\_RESET" and the firmware remains as is.

**NOTE:** "Enter Switch" lets the update goes on and the update will be done correctly, but the printer does not operate.

- <END: CMD Error: CONT>
  - Cause: No CRB file for data file.  
After data transfer, the printer displays this error before the version check.
  - Remedy:  
When "Menu Selection Switch" is pressed, the printer indicates "WAIT\_RESET" and the firmware remains as is.

**NOTE:** "Enter Switch" lets the update goes on and the update will be done correctly, but the printer soon stops because of error.



□ <END: Write. ER: CONT>

- Cause: Verify error during writing or erasing  
Same for when the verify error is occurred during DIMM erase and write and when the address write is out of range. Printer display indicates this error. DIMM pin contact failure and DIMM failure causes this error.
- Remedy:  
When "Menu Selection Switch" is pressed, the printer indicates "WAIT\_RESET" and the firmware remains as is.

**NOTE:** "Enter Switch" lets writing operation goes on regardless of error, but the printer may become unable to reboot because of checksum error.

□ <END: ADR. Error: CONT>

- Cause: DIMM write address is out of range.  
The data transferred from PC is converted and data different from data file is sent or the content of the data file has problem.
- Remedy:  
When "Menu Selection Switch" is pressed, the printer indicates "WAIT\_RESET" and the firmware remains as is.

**NOTE:** "Enter Switch" lets the update goes on and the update will be done correctly, but the printer soon stops because of error.

□ Service Call Error C\*\*\*\*\*

- Cause: Checksum error  
Writing to DIMM is failed. When you finished it without reading off the data, DIMM update program does not boot at the power on and the printer indicates error.
- Remedy:  
Press "On Line", "Alt" and "Value Selection Switch" twice at the same time. This will release error and DIMM update program is executed and you can update the data.

## 4.3.2 DIMM Module Copy

This section explains the method of directly copying the firmware or font data to DIMM module.

1. Install the target DIMM to socket A and master DIMM to socket B.
2. On the panel, while pressing the "READY\_TO\_PRINT", "Alt" and "Enter Switch", turn on the printer.
3. When the display indicates "ROM Copy Mode", press "Enter Switch". The printer enters to the DIMM copy mode.
4. Display indicates "C\*\*\*\*\* error" and the copy is completed.



- When removing and inserting the DIMM, make sure that the printer is OFF. Otherwise, you may damage DIMM.
- When DIMM is not installed at socket B, the firmware of the DIMM module connected to PROG socket will be copied to the target DIMM.

**CHAPTER**

**5**

**ADJUSTMENT**

## **5.1 Adjustment**

---

Adjustment is not required for EPSON AcuLaser C2000.

**CHAPTER**

**6**

**MAINTENANCE**

## 6.1 Maintenance

This chapter explains the maintenance of EPSON AcuLaser C2000. The maintenance of this product is designed for users to do maintenance.

No lubrication or adhesion is required for this product.

### 6.1.1 Replacement Parts

This product has the maintenance kit which includes required maintenance parts and thereby users can perform the maintenance. The following table shows the maintenance kit.

**Table 6-1. Replacement Item**

Name	Code	Replacement Timing	Note
ET cartridge (Yellow)		6,000 sheets	User replacement
ET cartridge (Magenta)		6,000 sheets	User replacement
ET cartridge (Cyan)		6,000 sheets	User replacement
ET cartridge (Black)		6,000 sheets	User replacement
OPC drum unit kit <ul style="list-style-type: none"> <li>• OPC unit</li> <li>• Fusing oil roll</li> <li>• Waste toner box</li> <li>• Printhead filter</li> </ul>		<ul style="list-style-type: none"> <li>• Monochrome <ul style="list-style-type: none"> <li>- Continuous printing: 30,000 sheets</li> <li>- 1 sheet printing: 10,000 sheets</li> </ul> </li> <li>• Color <ul style="list-style-type: none"> <li>- Continuous printing: 7,500 sheets</li> <li>- 1 sheet printing: 5,000 sheets</li> </ul> </li> </ul>	User replacement (Should be replaced at the same time.)
Fusing unit kit <ul style="list-style-type: none"> <li>• Fusing unit</li> <li>• 2nd Transfer Roll</li> </ul>		80,000 sheets	User replacement
Transfer belt		100,000 images	User replacement
Waste Toner Box		-	User replacement
Fusing oil roll (TBD)		-	User replacement

**NOTE:** Replacement timing is calculated in consideration for the product reliability and thereby it does not force the replacement at the described timing. Still, the replacement at the described timing is recommended for the product quality maintenance.

### 6.1.2 Cleaning

Clean the outer dirt by the dry and soft clean cloth. If the dirt is not easy to remove, use the neutral detergent. Vacuum the outer dust and paper strips. The following table shows the specific cleaning method you have to use for the specific parts. Otherwise, it may have the bad affect on the product function.

**Table 6-2. Cleaning**

Cleaning Part	Cleaning Method	Note
Paper load roller	Clean the roller surface with the dry and soft clean cloth.	User cleaning



**Do not use thinner or benzine since it may deteriorate the plastic parts and rubber parts.**

**CHAPTER**

**7**

**APPENDIX**

## 7.1 Overview

---

### 7.1.1 MCU Internal Connection Diagram

The following pages show MCU, Mechanical Computer Internal Connection Diagram.

# ELECTRICAL WIRING DIAGRAM

OPERATION PANEL

CONTROLLER

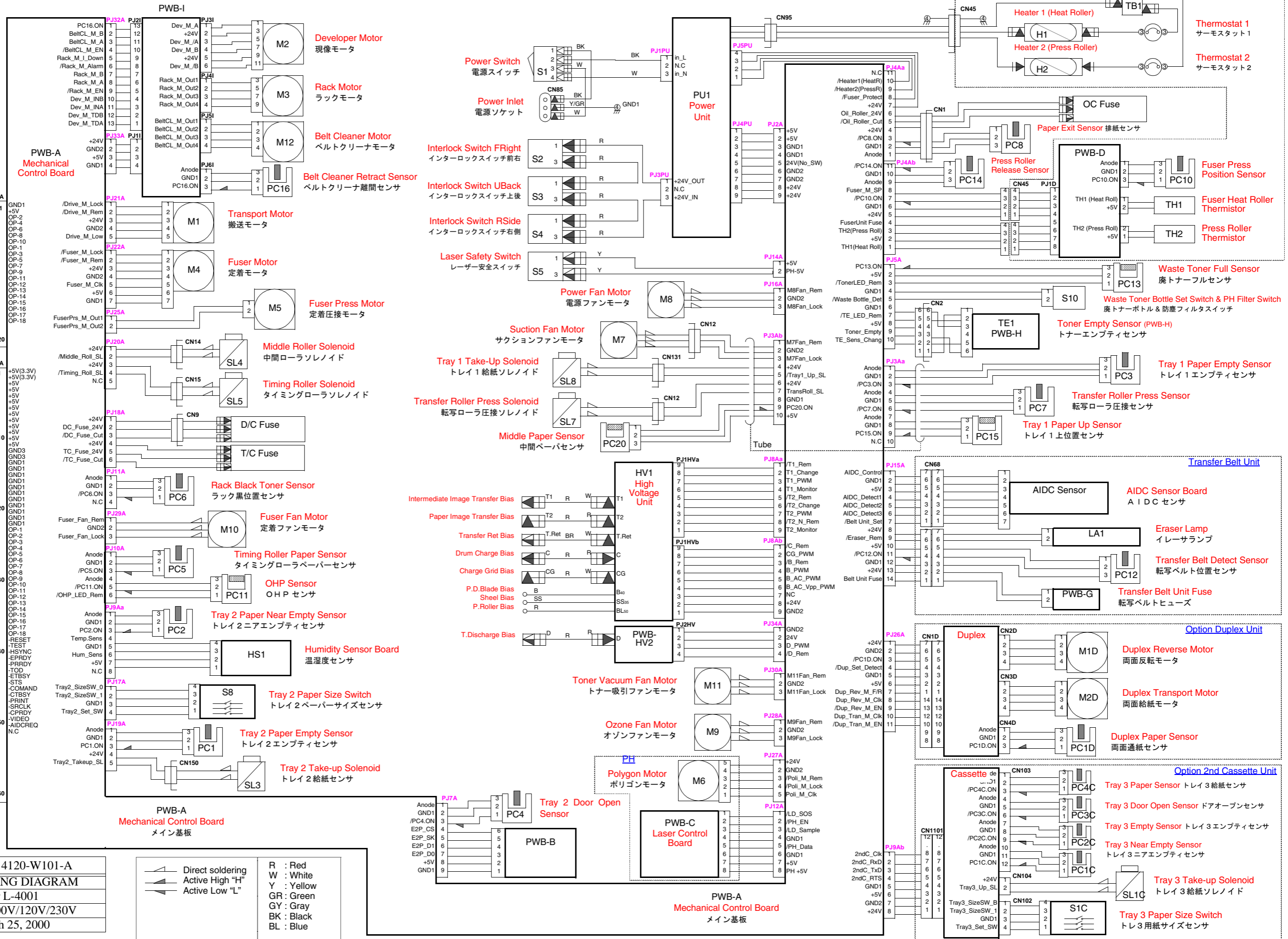

Drawing No.	4120-W101-A
Title	WIRING DIAGRAM
Model	Color L-4001
Voltage	AC100V/120V/230V
Date Issued	March 25, 2000

- Direct soldering
  - Active High "H"
  - Active Low "L"
- R : Red  
 W : White  
 Y : Yellow  
 GR : Green  
 GY : Gray  
 BK : Black  
 BL : Blue

OPERATION PANEL

CONTROLLER



## **7.2 Component Layout**

---

The following pages show the component layout of EPSON AcuLaser C2000.



2034951 00

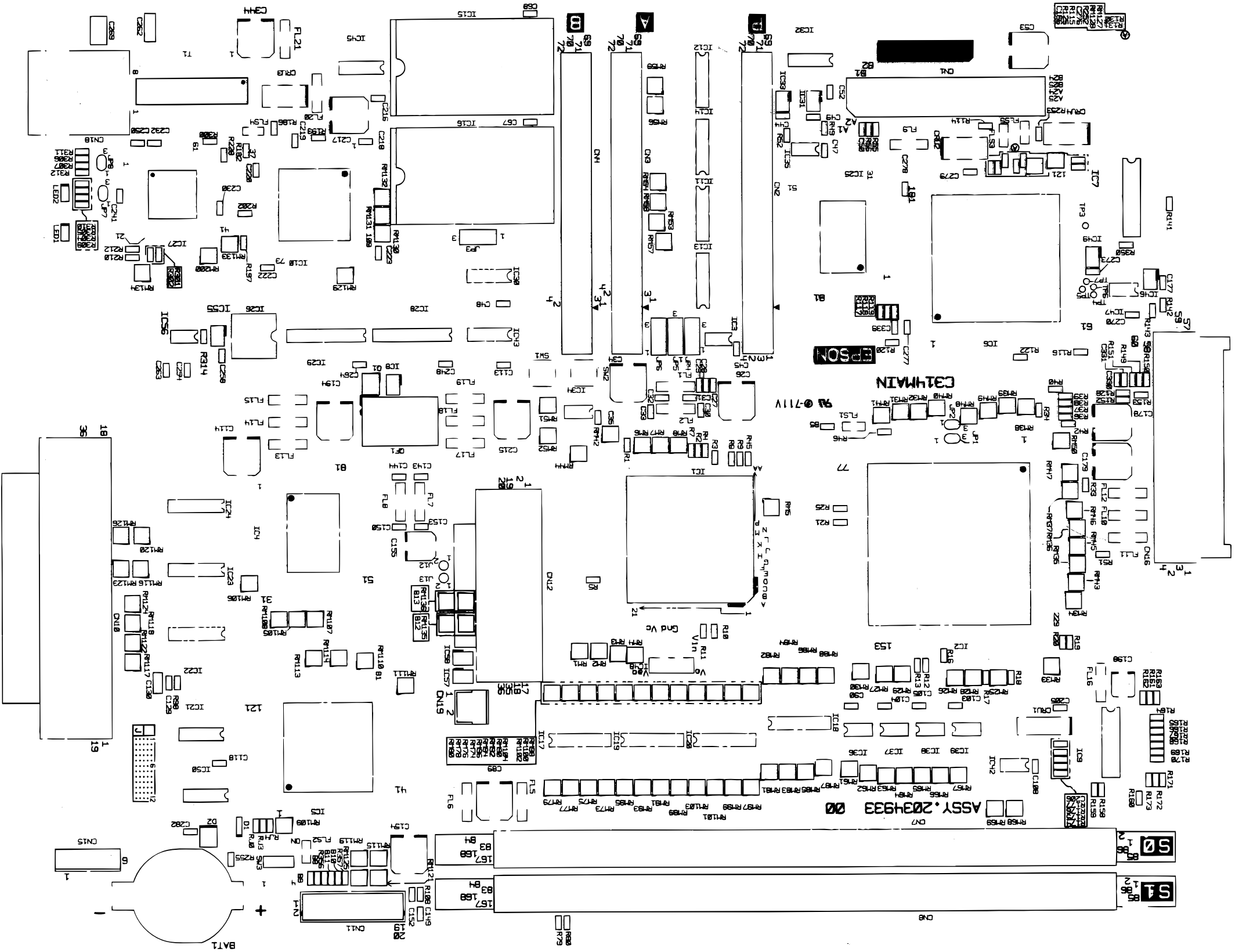

## **7.3 Exploded Diagram**

---

The following pages show the exploded diagram for EPSON AcuLaser C2000.

The parts to which no reference number is assigned will not be available as after-sale service parts.

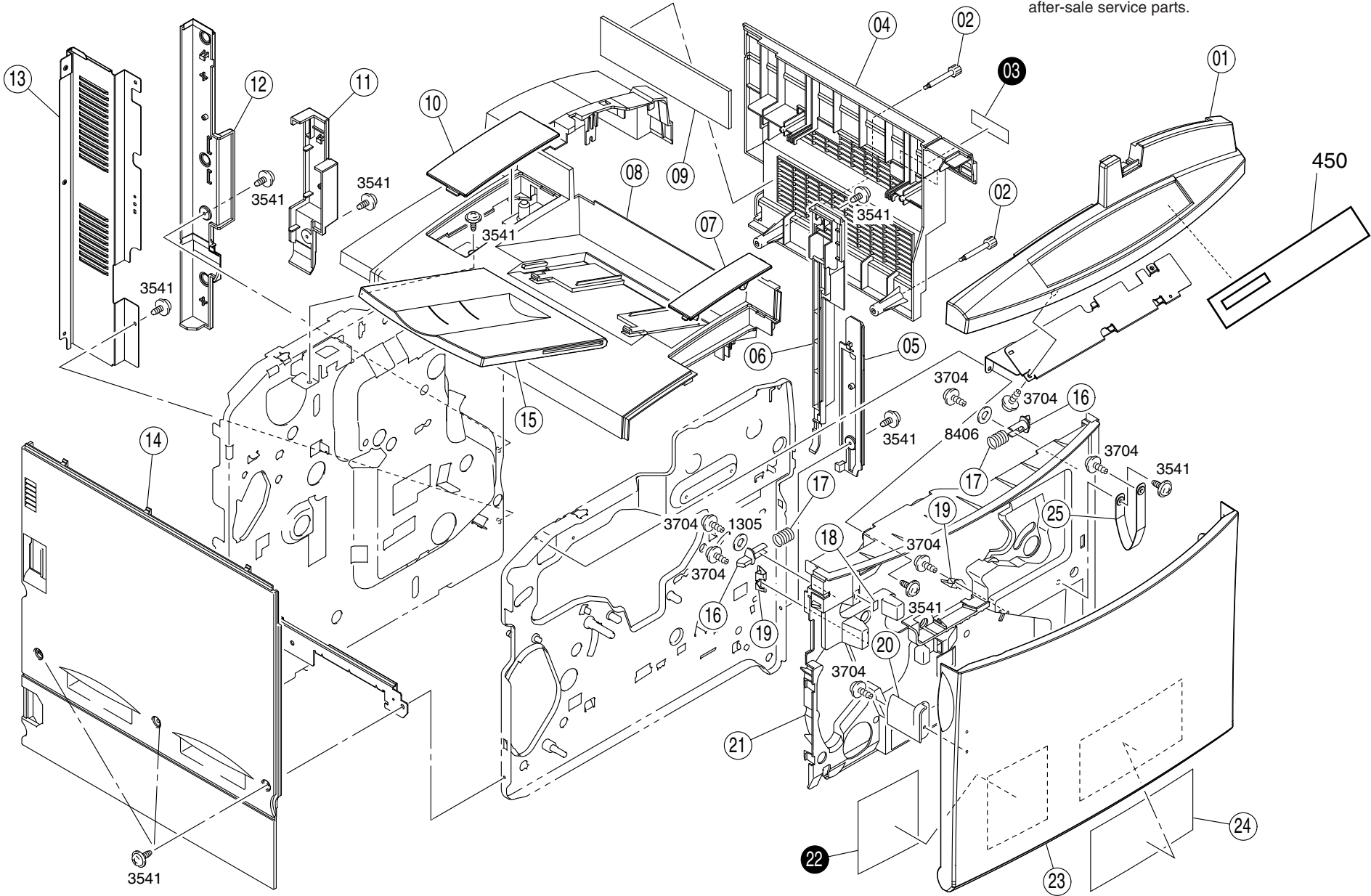

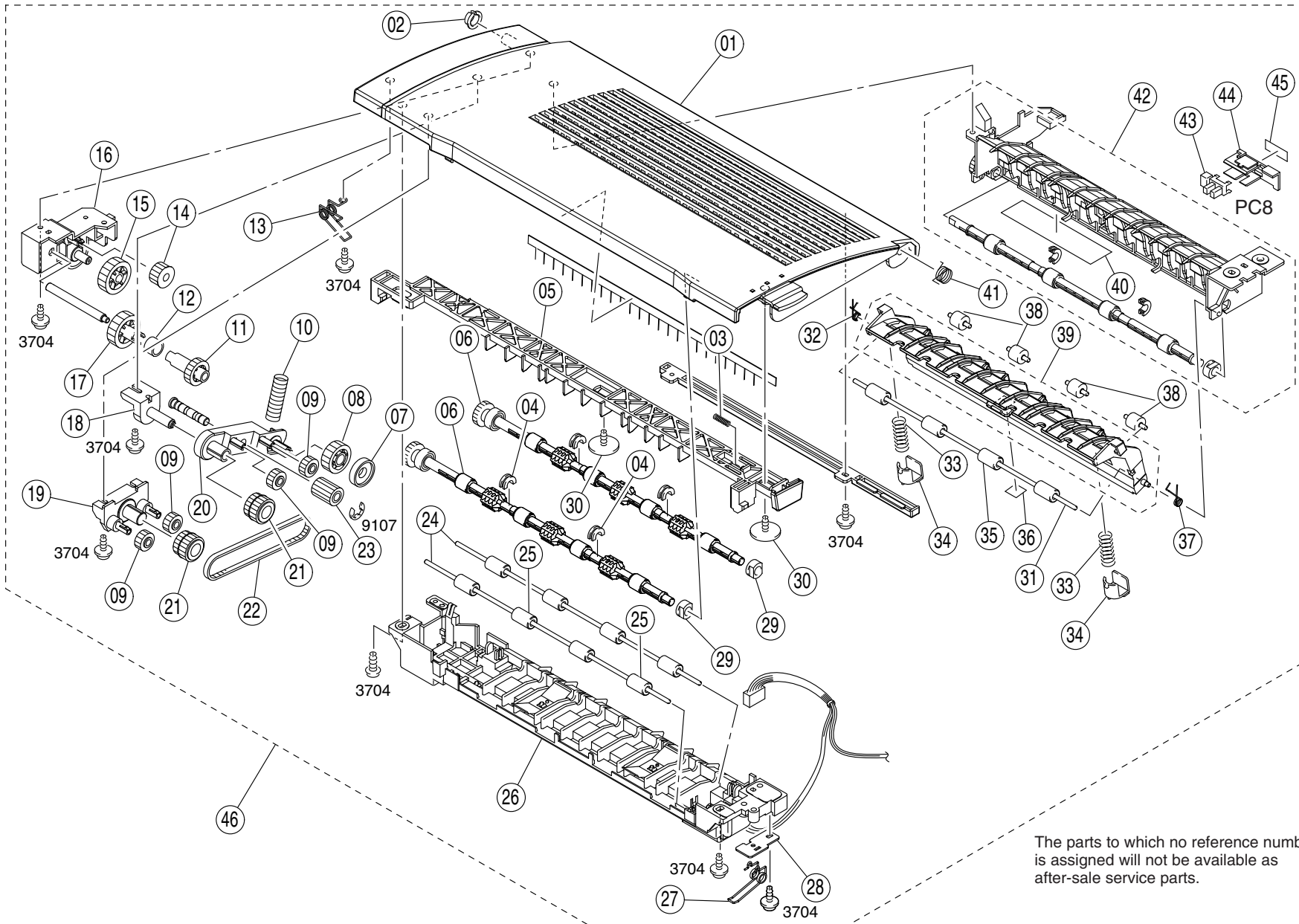

The parts to which no reference number is assigned will not be available as after-sale service parts.

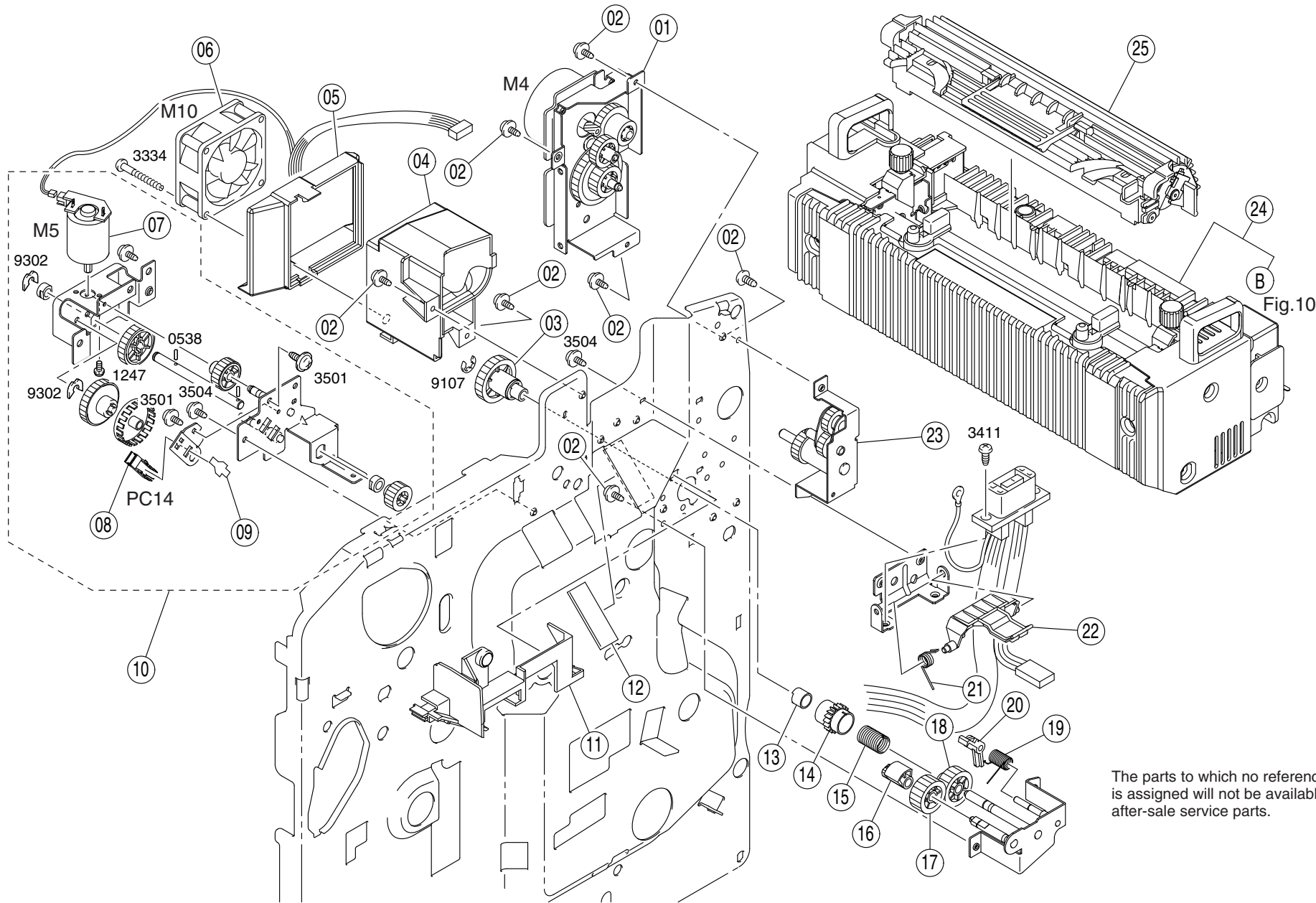
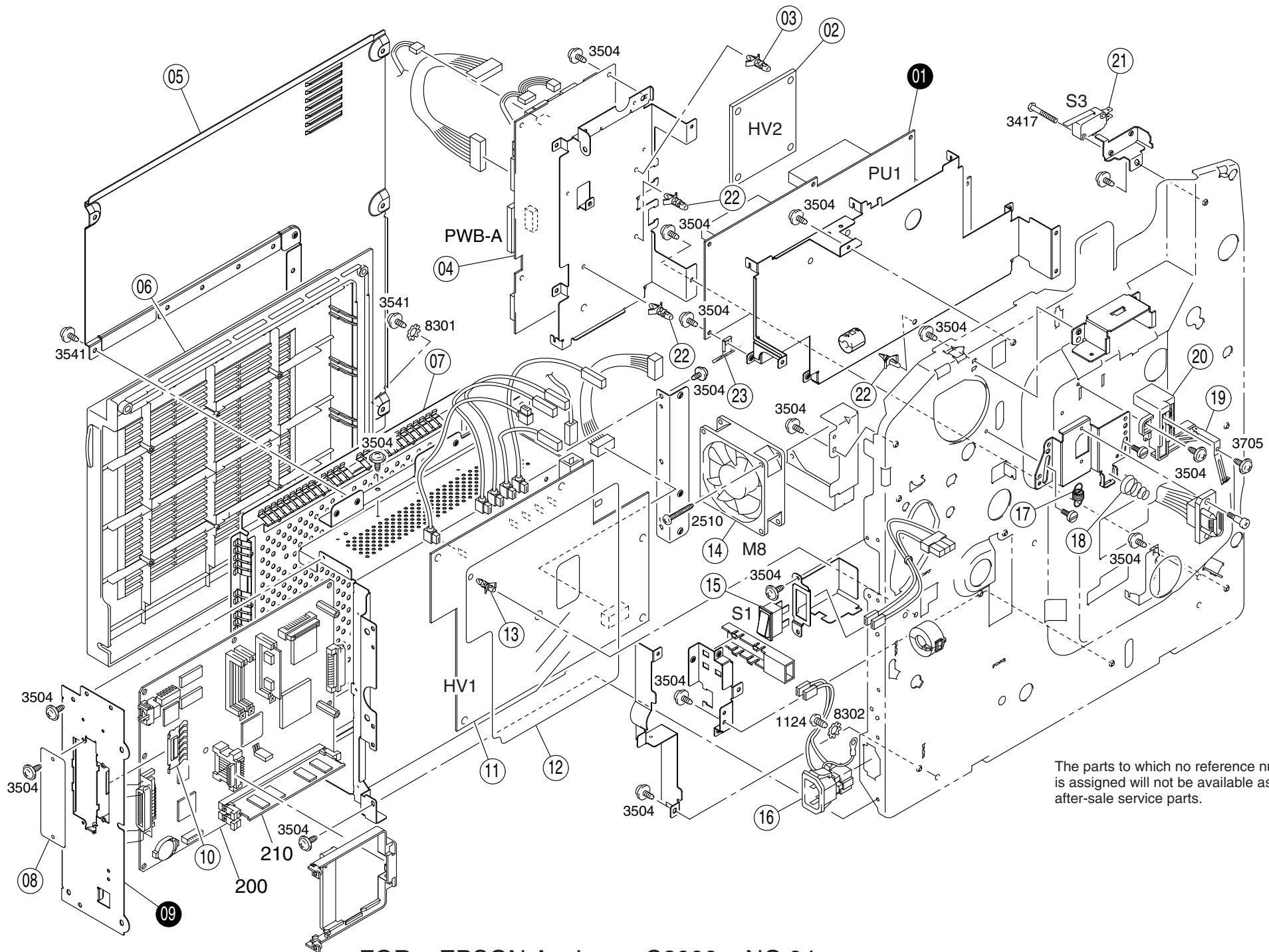

Fig.10

The parts to which no reference number is assigned will not be available as after-sale service parts.



The parts to which no reference number is assigned will not be available as after-sale service parts.



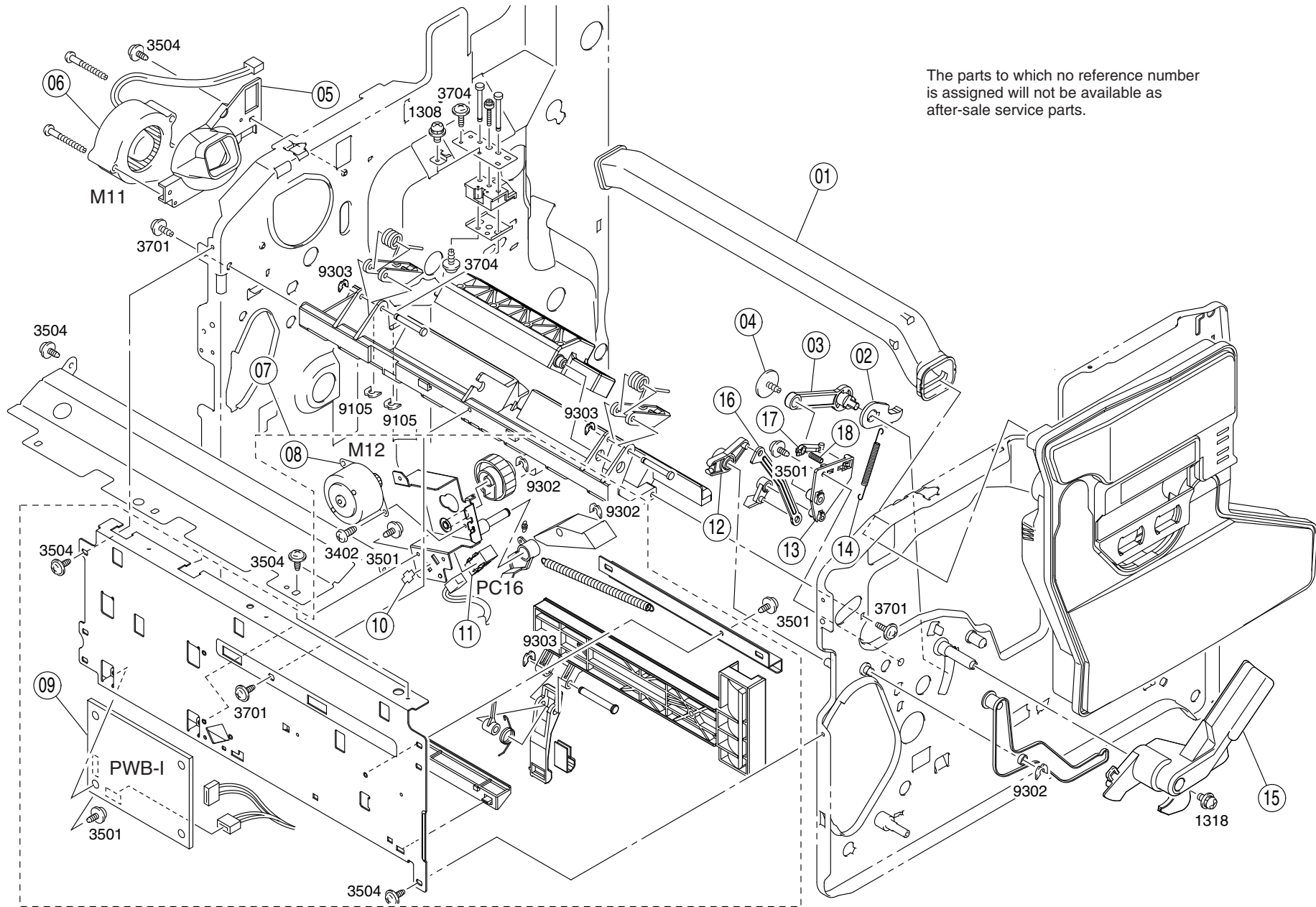

The parts to which no reference number is assigned will not be available as after-sale service parts.

The parts to which no reference number is assigned will not be available as after-sale service parts.

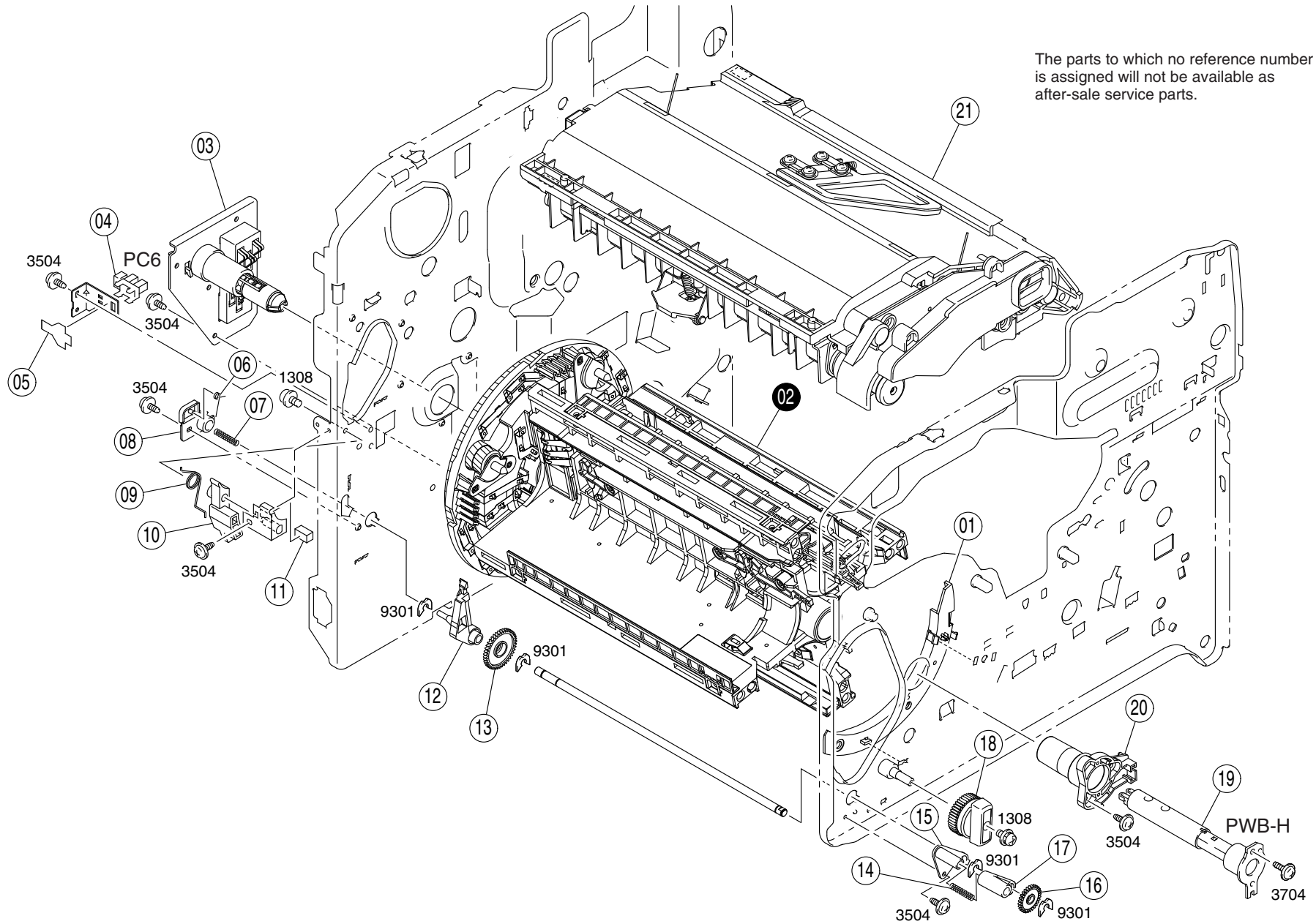

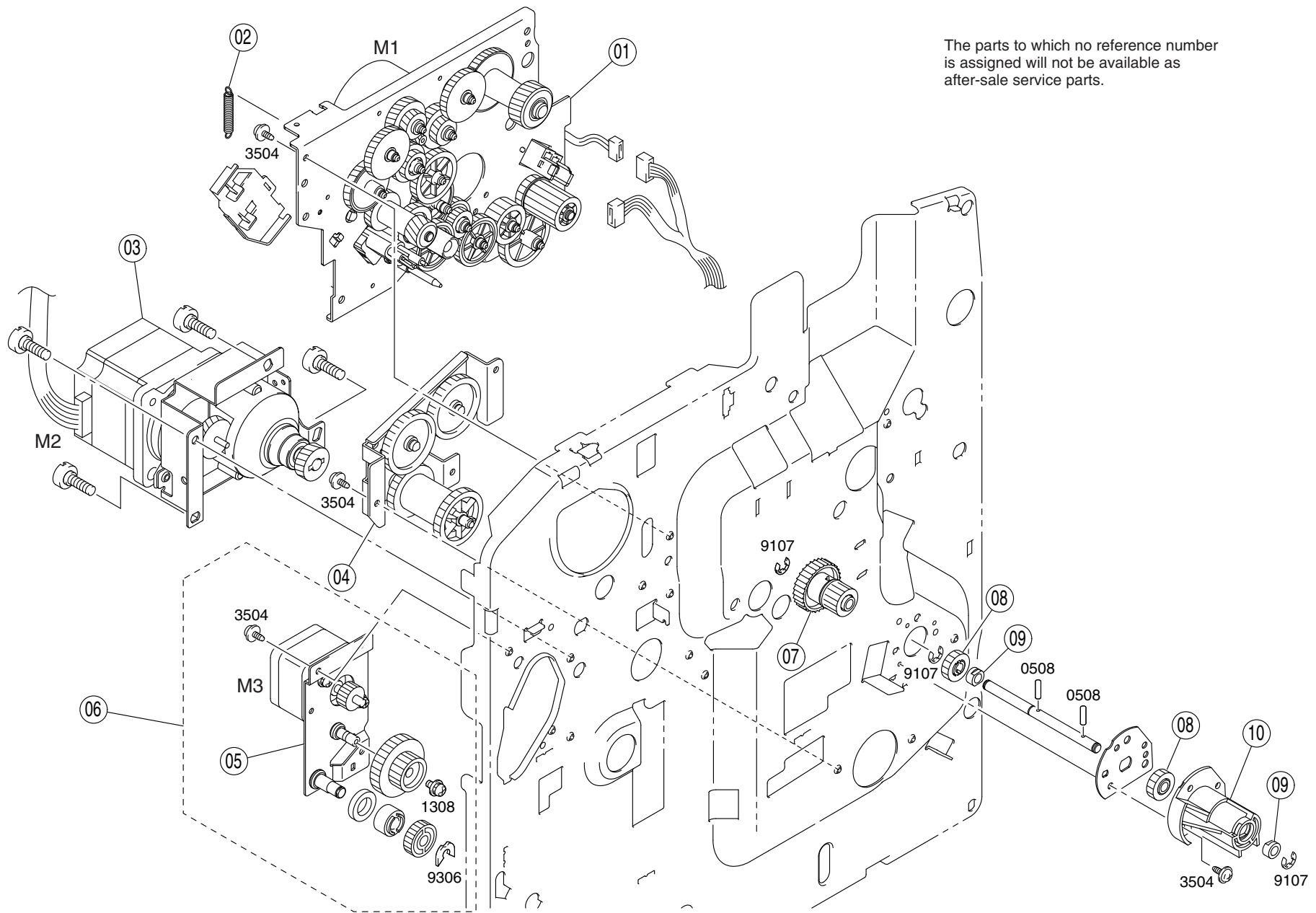

The parts to which no reference number is assigned will not be available as after-sale service parts.

The parts to which no reference number is assigned will not be available as after-sale service parts.

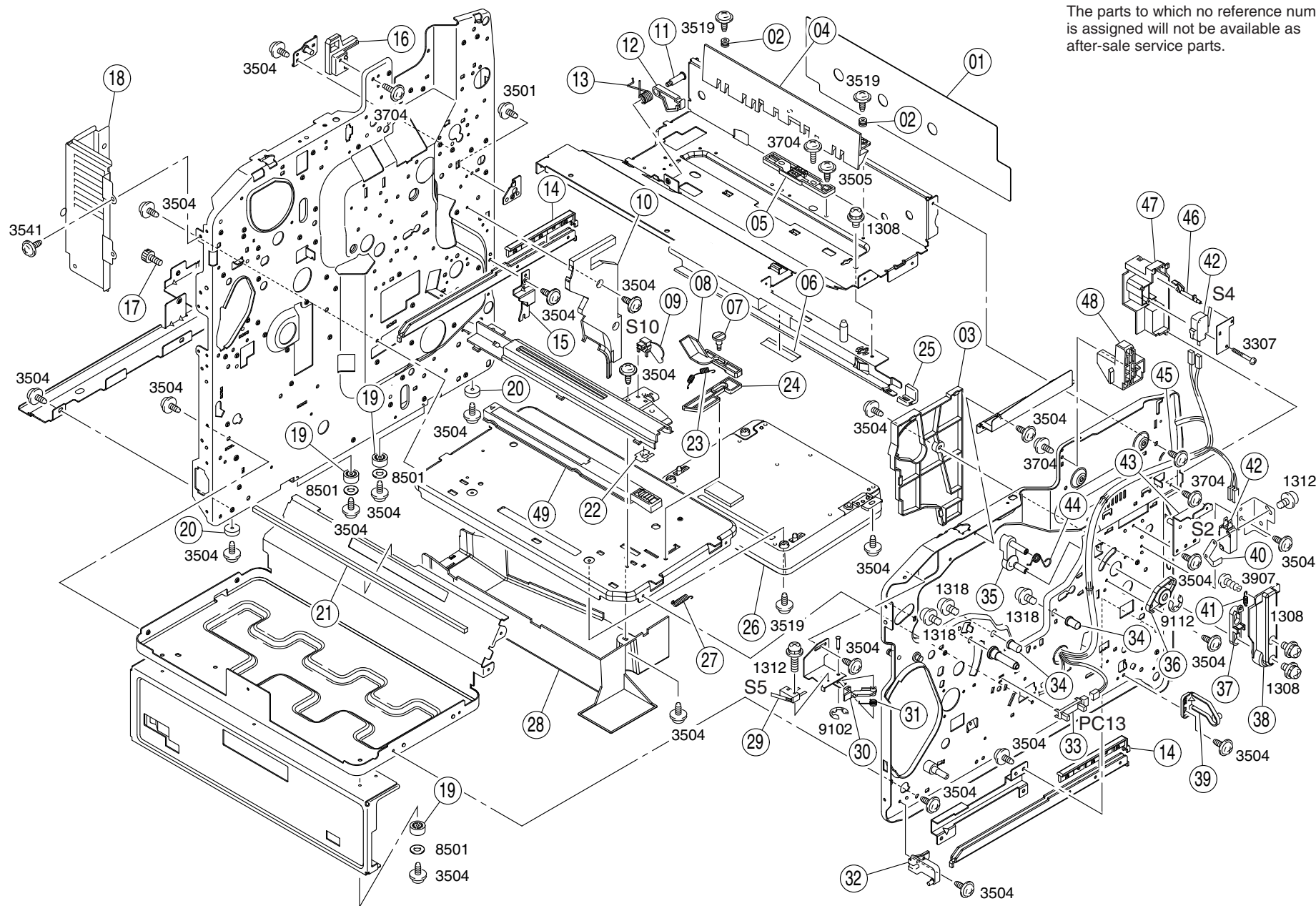

The parts to which no reference number is assigned will not be available as after-sale service parts.

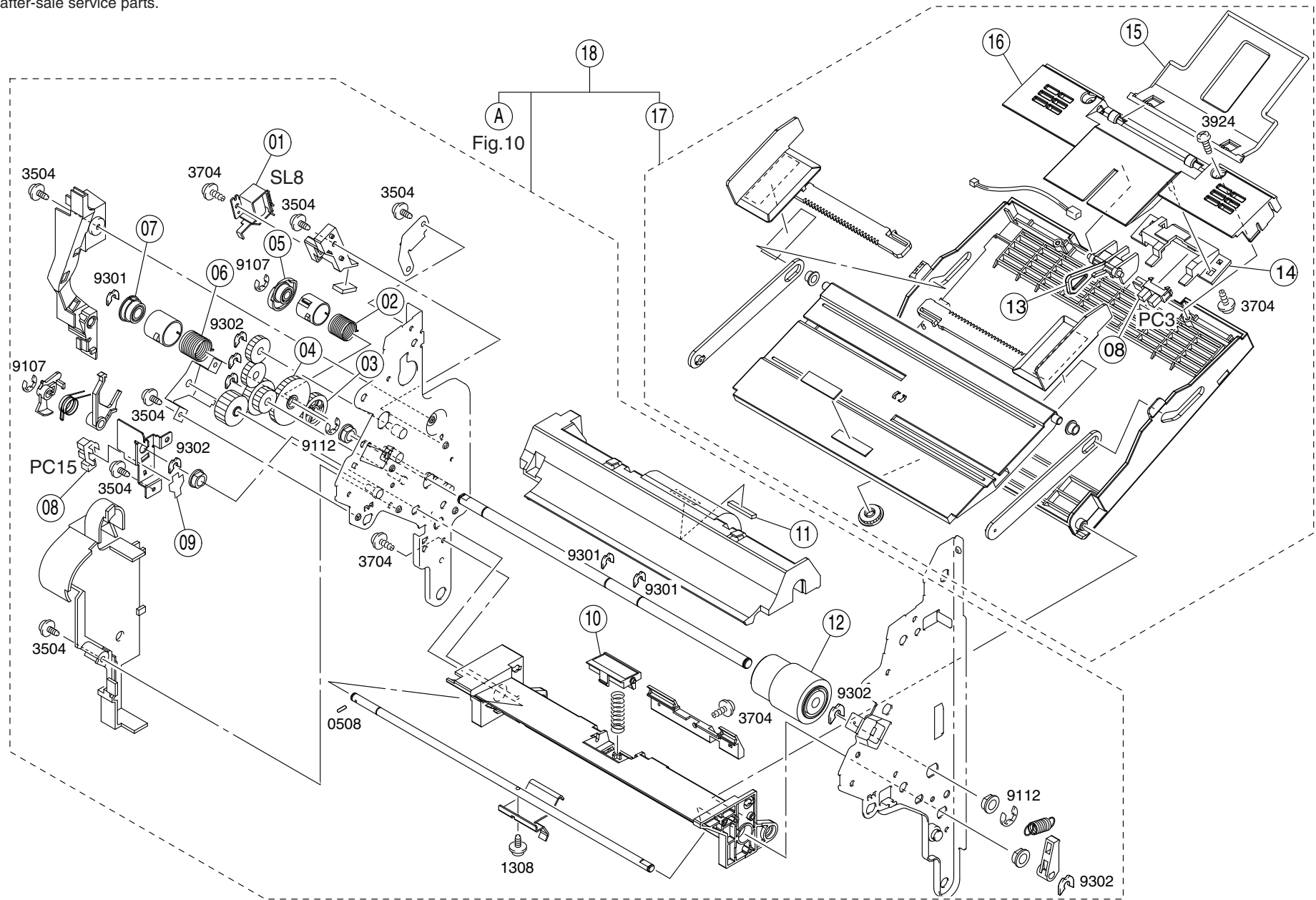

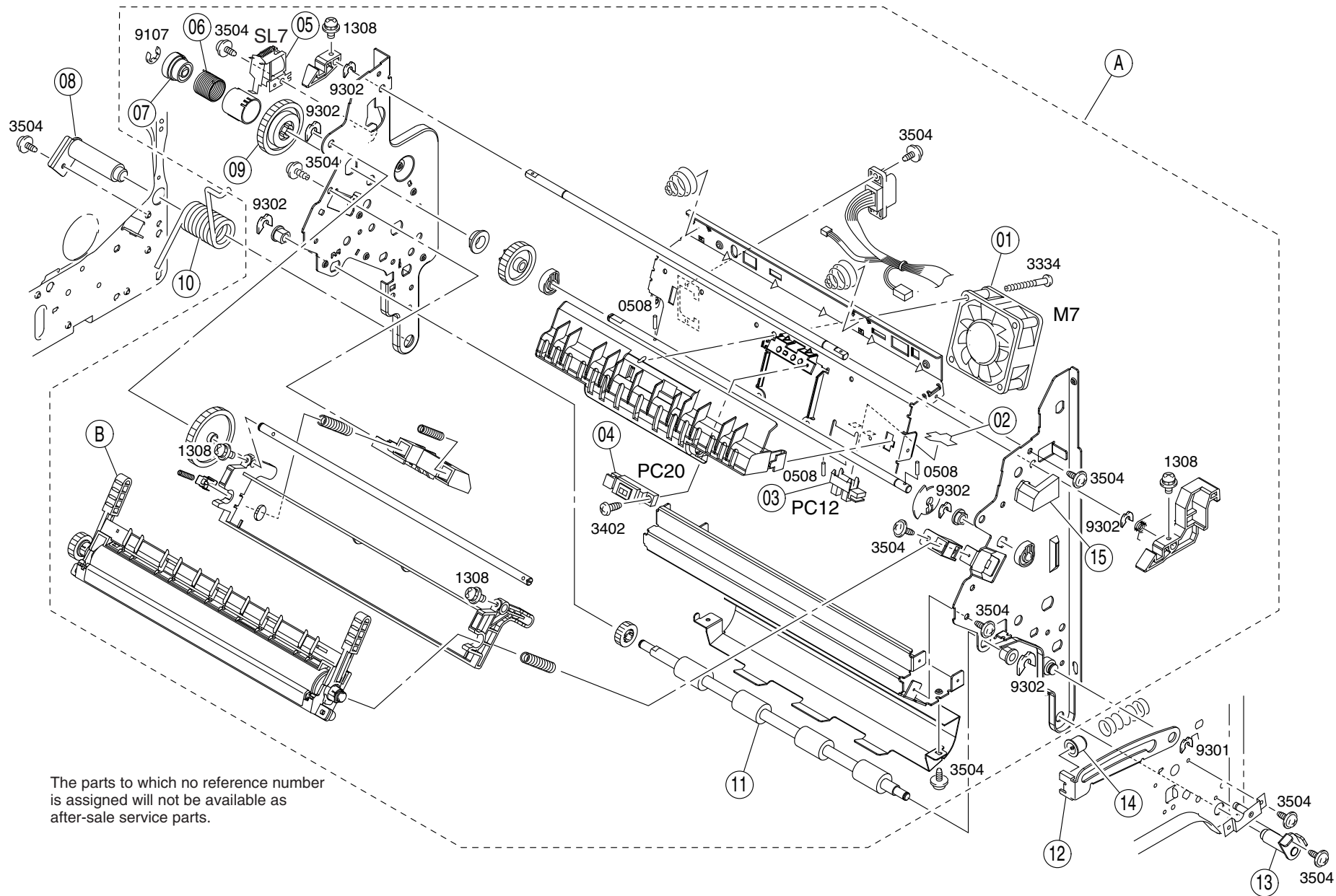

The parts to which no reference number is assigned will not be available as after-sale service parts.

The parts to which no reference number is assigned will not be available as after-sale service parts.

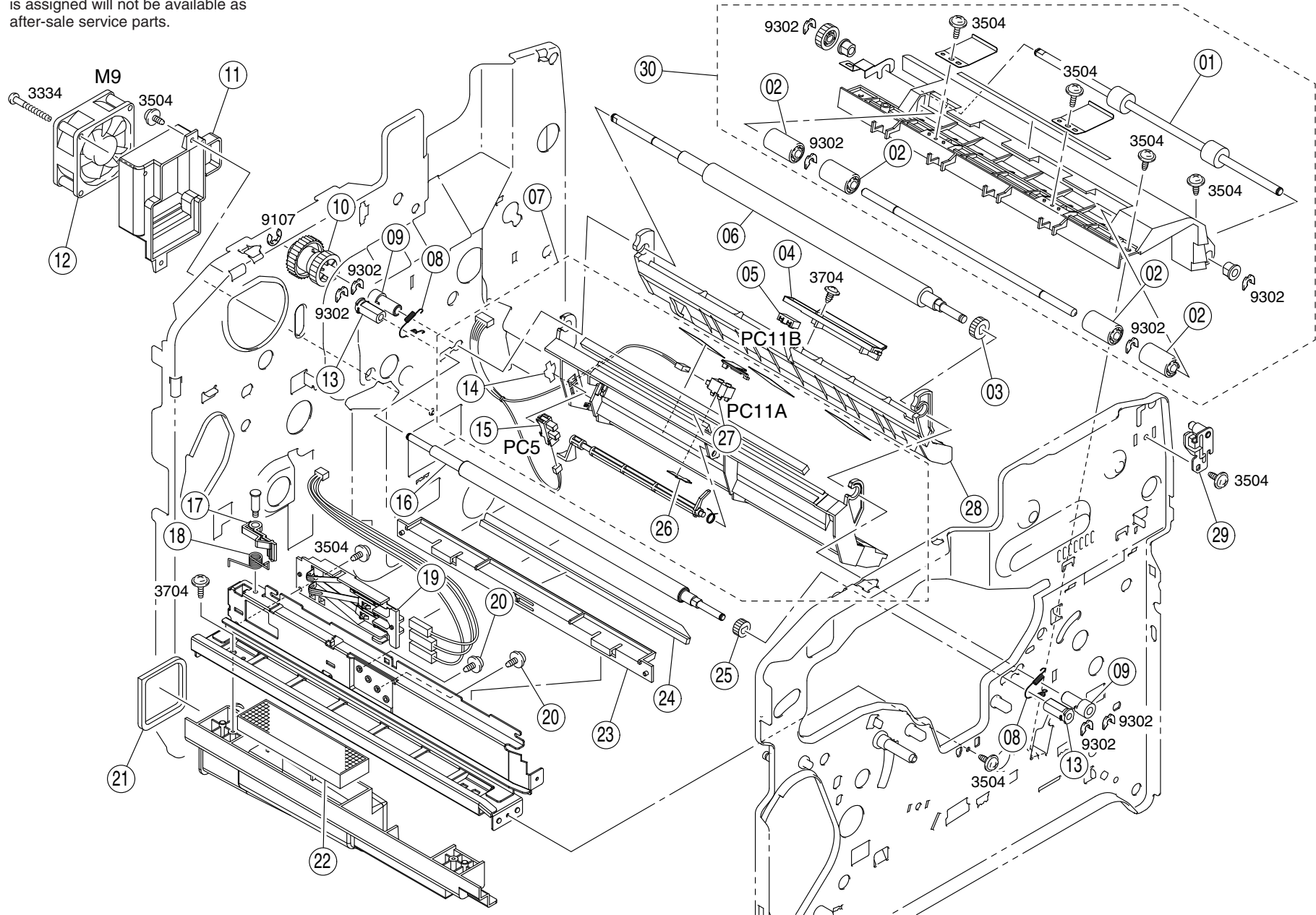

The parts to which no reference number is assigned will not be available as after-sale service parts.

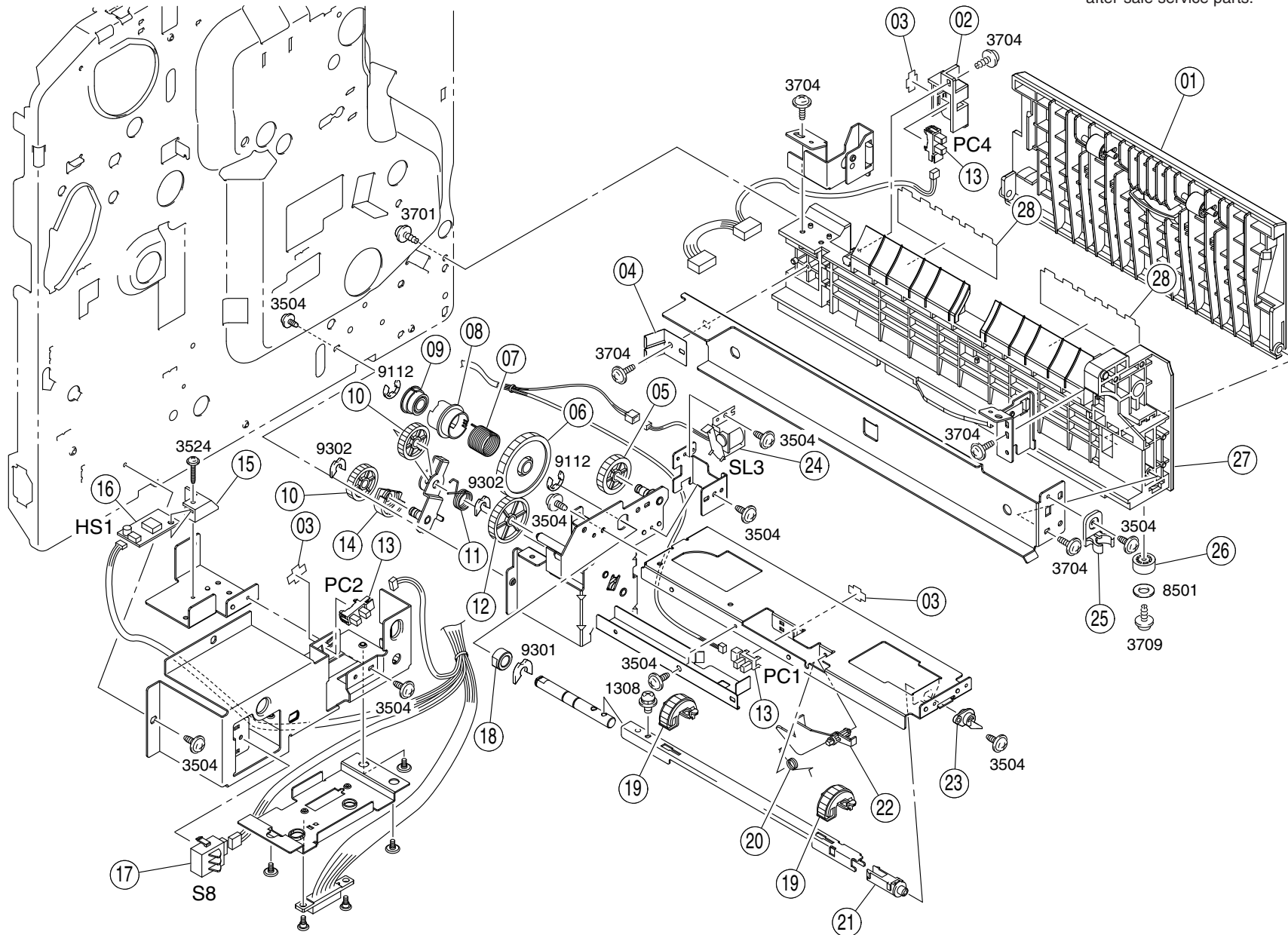



The parts to which no reference number is assigned will not be available as after-sale service parts.

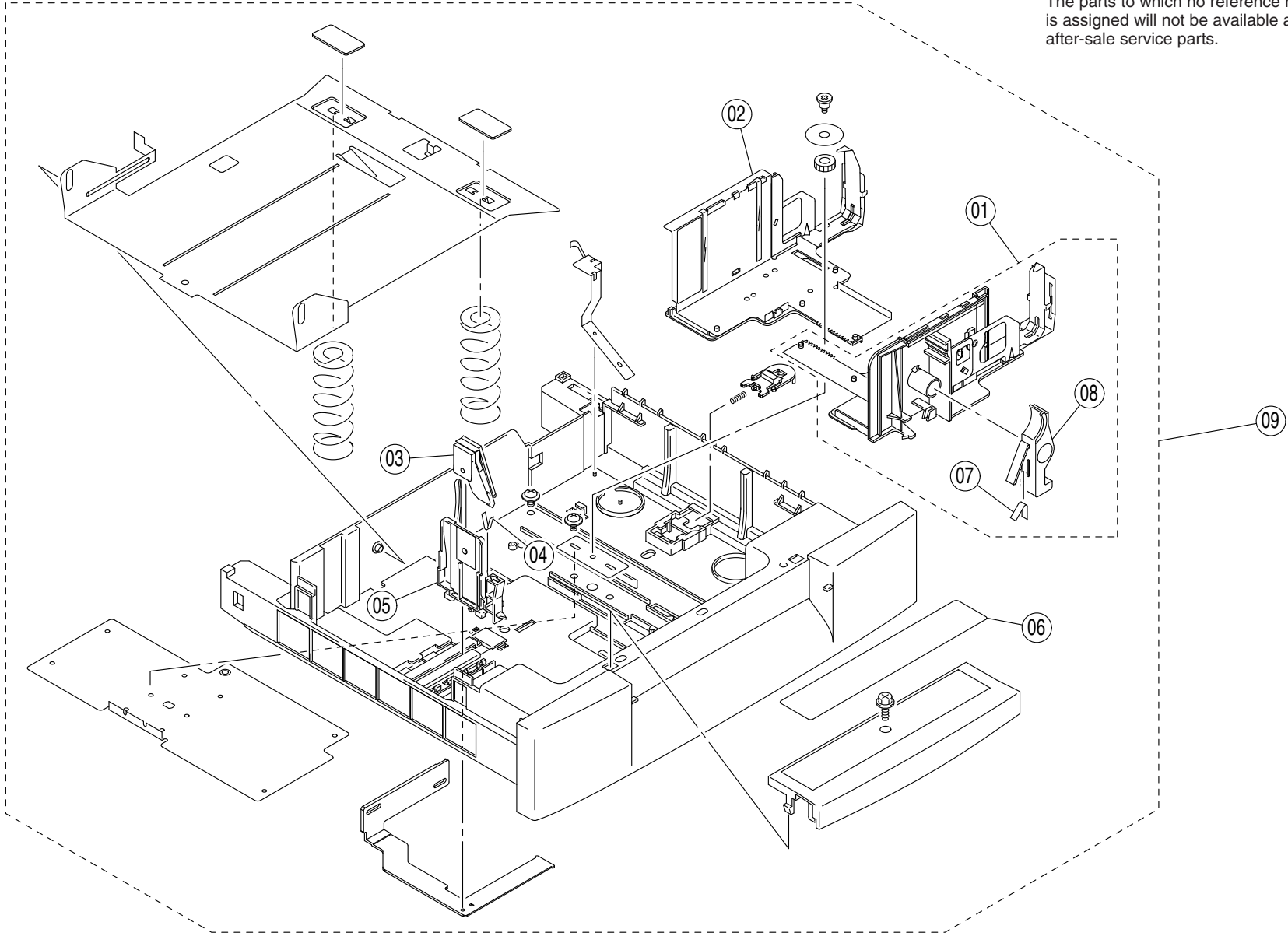

The parts to which no reference number is assigned will not be available as after-sale service parts.

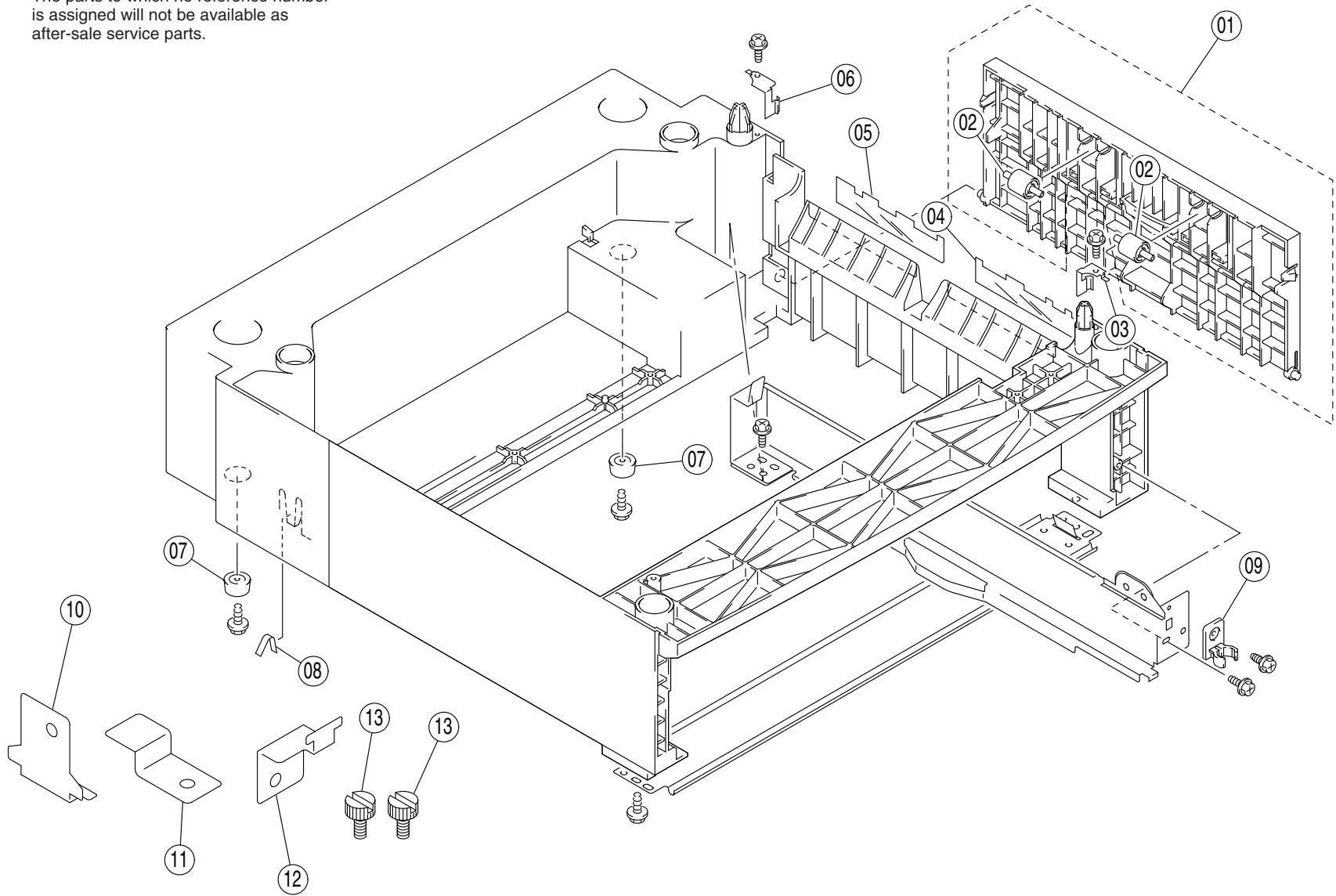

The parts to which no reference number is assigned will not be available as after-sale service parts.

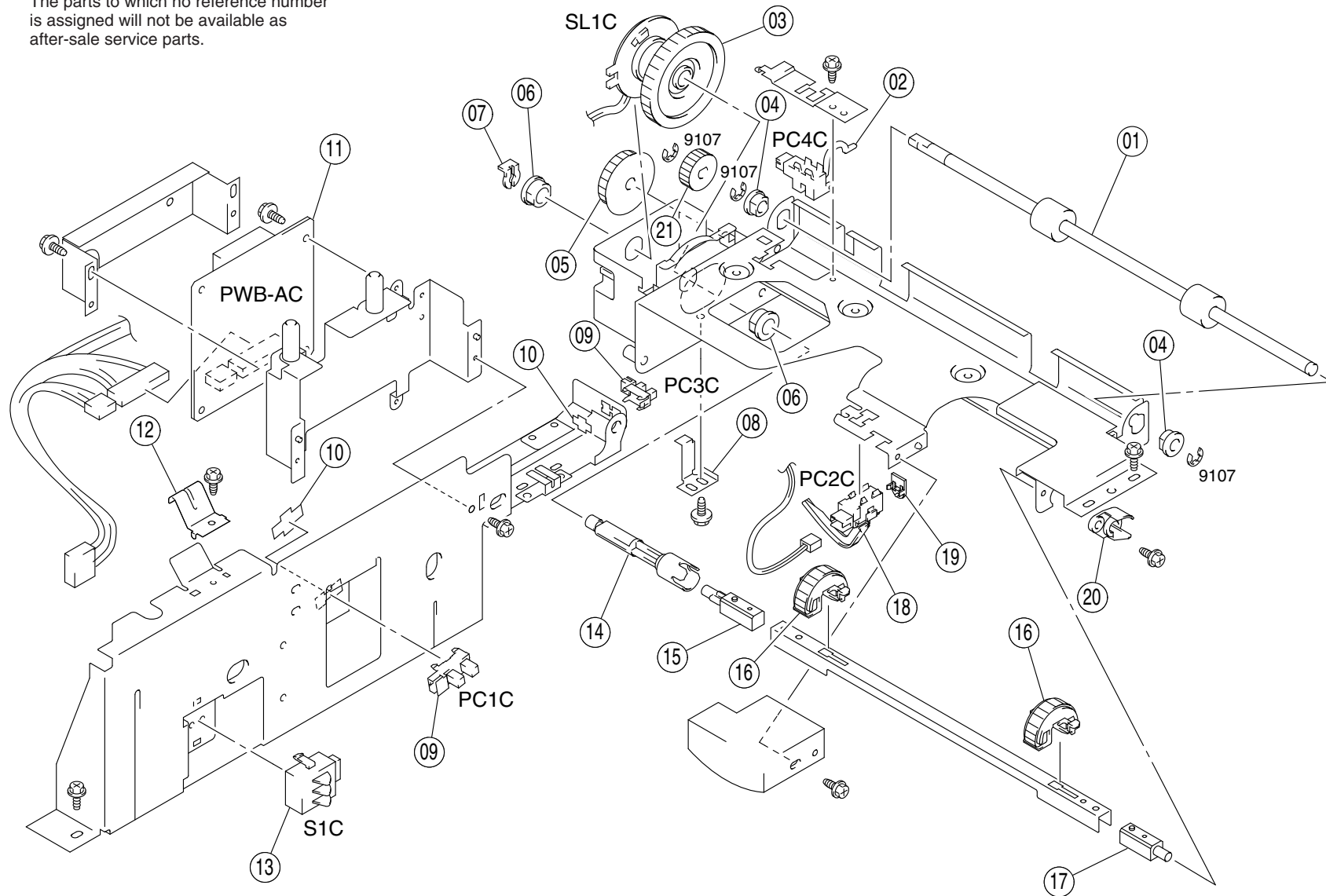

The parts to which no reference number is assigned will not be available as after-sale service parts.

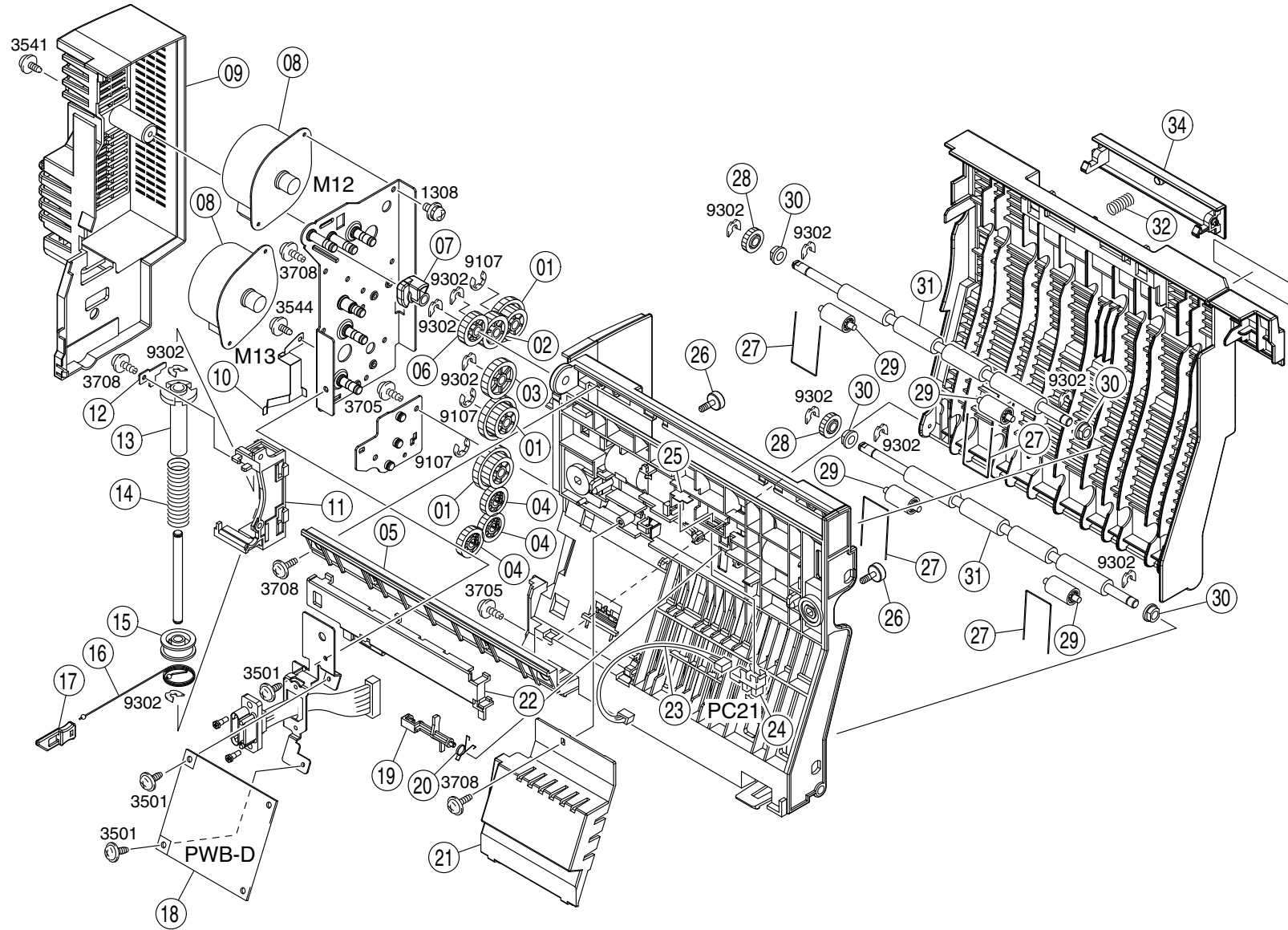

## 7.4 Parts List

The numbers on the list corresponds with numbers in the exploded diagrams.

For example, 1-01 corresponds with 01 on the exploded diagram 1.

The Table 7-1 is for the main body of EPSON AcuLaser C2000; is for the 500 Sheet Paper Cassette Unit and is for Duplex unit.

**Table 7-1. Main Body -- Parts List**

Number	Name
1-01	COVER
1-02	SCREW
1-03	LABEL
1-04	RIGHT COVER
1-05	RIGHT COVER
1-06	RIGHT COVER
1-07	COVER
1-08	TOP COVER
1-09	FILTER
1-10	COVER
1-11	RIGHT COVER
1-12	RIGHT COVER
1-13	REAR COVER
1-14	LEFT COVER
1-15	TRAY
1-16	PAWL
1-17	PRESSURE SPRING
1-18	LABEL
1-19	PLATE SUPRING

**Table 7-1. Main Body -- Parts List**

Number	Name
1-20	SET PLATE
1-21	COVER
1-22	LABEL
1-23	FRONT COVER
1-24	LABEL,DC/PH/I.T.U CHANGE
1-25	BAND
2-01	COVER ASSY
2-02	BUSHING
2-03	PRESSURE SPRING
2-04	BUSHING
2-05	LEVER
2-06	ROLLER ASSY
2-07	COLLAR
2-08	GEAR
2-09	GEAR
2-10	PRESSURE SPRING
2-11	GEAR
2-12	COLLASR
2-13	TORSION SPRING
2-14	GEAR
2-15	GEAR
2-16	HOLDER
2-17	GEAR
2-18	HOLDER
2-19	HOLDER

Table 7-1. Main Body -- Parts List

Number	Name
2-20	LEVER
2-21	PULLEY
2-22	TIMINGBELT
2-23	GEAR
2-24	SHAFT
2-25	ROLL
2-26	GUIDE ASSY
2-27	TORSION SPRING
2-28	SET PLATE
2-29	BUSHING
2-30	SCREW
2-31	SHAFT
2-32	TORSION SPRING
2-33	PRESSURE SPRING
2-34	HOLDER
2-35	ROLL
2-37	TORSION SPRING
2-38	ROLL
2-39	GUIDE ASSY
2-40	LABEL
2-41	TORSION SPRING
2-42	GUIDE ASSY
2-43	SOLID STATE SWITCH
2-44	BRACKET
2-45	STOPPER

Table 7-1. Main Body -- Parts List

Number	Name
2-46	GUIDE ASSY
3-01	FUSING UNIT DRIVE ASSY
3-02	SCREW
3-03	GEAR
3-04	DUCT
3-05	DUCT
3-06	FUN MOTOR
3-07	ALIENATION MOTOR ASSY
3-08	SOLID STATE SWITCH
3-09	STOPPER
3-10	STOP PLATE ASSY
3-11	CIVER
3-12	PROTECTION
3-13	COLLAR
3-14	RATCHET
3-15	TORSION SPRING
3-16	REGULATING PLATE
3-17	GEAR
3-18	GEAR
3-19	TORSION SPY.G
3-20	PAWL
3-21	TORSION SPRING
3-22	SHUTTER
3-23	FUSING UNIT DRIVE 3 ASSY
3-24	FUSER UNIT 220V

Table 7-1. Main Body -- Parts List

Number	Name
3-25	FUSER OIL ROLL
3-36	LABEL
4-01	POWER SUPPLY
4-02	HV TRANSFORMER
4-03	PWB SUPPORT 6.35H
4-04	PWB ASSY
4-05	REAR COVER
4-06	COVER
4-07	COVER
4-08	COVER
4-09	BRACKET
4-10	GROUND PLATE
4-11	HV TRANSFORMER
4-12	COVER
4-13	PWB SUPPORT9.53H
4-14	FUN MOTOR
4-15	SWITCH
4-16	HARNESS ASSY
4-17	TENSION SPRING
4-18	PRESSURE SPRING
4-19	CONTACT
4-20	GUIDE ASSY
4-21	MICRO SWITCH
4-22	PWB SUPPORT
4-23	EARTH GROUND

Table 7-1. Main Body -- Parts List

Number	Name
5-01	DUCT ASSY
5-02	LEVER
5-03	LEVER
5-04	SCREW
5-05	DUCT
5-06	FUN MOTOR
5-07	LEVER ASSY
5-08	MOTOR
5-09	PWB ASSY
5-10	STOPPER
5-11	SOLID STATE SWITCH
5-12	LEVER
5-13	HOLDER
5-14	TENSION SPRING
5-15	LEVER ASSY
5-16	LEVER
5-17	LEVER
5-18	PRESSURE SPRING
6-01	GUIDE
6-02	RACK ASSY
6-03	AXLE PLATE ASSY
6-04	SOLID STATE SWITCH
6-05	STOPPER
6-06	TPRSION SPRING
6-07	PRESSURE SPRING

Table 7-1. Main Body -- Parts List

Number	Name
6-08	BUSHING
6-09	TORSION SPRING
6-10	LEVER
6-11	SOUND SHIELD
6-12	LEVER
6-13	GEAR
6-14	PRESSURE SPRING
6-15	BUSHING
6-16	GEAR
6-17	LEVER
6-18	KNOB ASSY
6-19	PWB ASSY
6-20	SHAFT
6-21	TRANSFER BELT UNIT
7-01	DRIVING ASSY
7-02	TENSION SPRING
7-03	MOTOR ASSY
7-04	DRIVING ASSY
7-05	MOTOR ASSY
7-06	MOTOR ASSY
7-07	CLUTCH ASSY
7-08	GEAR
7-09	BUSHING
7-10	HOLDER
8-01	PROTECTION

Table 7-1. Main Body -- Parts List

Number	Name
8-02	SPACER
8-03	COVER
8-04	GUIDE
8-05	HOLDER ASSY
8-06	SHIELD PLATE
8-07	SHOULDER SCREW
8-08	LEVER
8-09	SWITCH
8-10	COVER
8-11	SHOULDER SCREW
8-12	LEVER
8-13	TORSION SPRING
8-14	CAP
8-15	BRACKET
8-16	STOPPER
8-17	SCREW
8-18	REAR COVER
8-19	RUBBER FOOT
8-20	COLLAR
8-21	SEAL
8-22	STOPPER
8-23	TENSION SPRING
8-24	LEVER
8-25	GUIDE
8-26	PRINT HEAD ASSY



Table 7-1. Main Body -- Parts List

Number	Name
8-27	TENSION SPRING
8-28	DUCT
8-29	MICRO SWITCH
8-30	LEVER
8-31	TORSION SPRING
8-32	HINGE
8-33	SOLID STATE SWITCH
8-34	PIN
8-35	LEVER
8-36	BUSHING
8-37	LEVER
8-38	LEVER
8-39	HINGE
8-40	PLATE NUT
8-41	TENSION SPRING
8-42	MICRO SWITCH
8-43	CALKING ASSY
8-44	TORSION SPRING
8-45	SCREW
8-46	LEVER
8-47	HOLDER
8-48	STOPPER
8-49	PRINT HEAD FILTER
9-01	SOLENOID
9-02	TORSION SPRING

Table 7-1. Main Body -- Parts List

Number	Name
9-03	GEAR
9-04	GEAR
9-05	CAM
9-06	CLUTCH SPRING
9-07	DRUM
9-08	SOLID STATE SWITCH
9-09	STOPPER
9-10	SEPARATOR ASSY
9-11	SPONGE
9-12	ROLLER
9-13	ACTUATOR
9-14	HOLDER
9-15	TRAY
9-16	COVER
9-17	MULTIPLE TRAY ASSY
9-18	SIDE OPEN ASSY
10-01	FUN MOTOR
10-02	STOPPER
10-03	SOLID STATE SWITCH
10-04	SENSOR ASSY
10-05	SOLENOID
10-06	TORSION SPRING
10-07	DRUM
10-08	CALKING ASSY
10-09	GEAR

Table 7-1. Main Body -- Parts List

Number	Name
10-10	TORSION SPRING
10-11	ROLLER
10-12	LEVER
10-13	SHAFT ASSY
10-14	HOLDER
10-15	DUCT
10-B	SECOND TRANSFER ROLL
11-01	ROLLER
11-02	ROLL
11-03	GEAR
11-04	HANDLE
11-05	SOLID STATE SWITCH
11-06	ROLLER
11-07	GUIDE ASSY
11-08	TORSION SPRING
11-09	BUSHING
11-10	CLUTCH ASSY
11-11	DUCT
11-12	FUN MOTOR
11-13	BUSHING
11-14	STOPPER
11-15	SOLID STATE SWITCH
11-16	ROLLER
11-17	LEVER
11-18	TORSION SPRING

Table 7-1. Main Body -- Parts List

Number	Name
11-19	HOLDER ASSY
11-20	SCREW
11-21	SEAL
11-22	FILTER
11-23	GUIDE
11-24	GUIDE
11-25	GEAR
11-26	STOPPER
11-27	SOLID STATE SWITCH
11-28	GUIDE
11-29	CALKING ASSY
11-30	GUIDE ASSY
12-01	TRANSPORT ASSY
12-02	HOLDER
12-03	STOPPER
12-04	PLATE SPRING
12-05	GEAR
12-06	GEAR
12-07	TORSION SPRING
12-08	HOLDER
12-09	DRUM
12-10	GEAR
12-11	TORSION SPRING
12-12	GEAR
12-13	SOLID STATE SWITCH

Table 7-1. Main Body -- Parts List

Number	Name
12-14	COLLAR
12-15	HOLDER
12-16	HUMIDITY CONVERSION EL
12-17	SWITCH(SW21)
12-18	BUSHING
12-19	ROLLER ASSY
12-20	TORSION SPRING
12-21	SHAFT
12-22	ACTUATOR
12-23	BUSHING
12-24	SOLENOID
12-25	GUIDE
12-26	RUBBER FOOT
12-27	GUIDE
12-28	GUIDE
13-01	REGULATING PLATE ASSY
13-02	REGULATING PLATE ASSY
13-03	REGULATING PLATE ASSY
13-04	PLATE SPRING
13-05	REGULATING PLATE
13-06	LABEL
13-07	PLATE SPRING
13-08	LEVER
13-09	CASSETTE ASSY

Table 1-3. 500 Sheet Paper Cassette Unit - Parts List

Number	Name
14-01	GUIDE ASSY
14-02	ROLL
14-03	PLATE SPRING
14-04	GUIDE
14-05	GUIDE
14-06	PLATE SPRING
14-07	RUBBER FOOT
14-08	PLATE SPRING
14-09	GUIDE
14-10	COUPLING
14-11	COUPLING
14-12	COUPLING
14-13	SCREW
15-01	ROLLER
15-02	SOLID STATE SWITCH
15-03	CLUTCH
15-04	BUSHING
15-05	GEAR
15-06	BUSHING
15-07	STOP RING
15-08	STOPPER
15-09	SOLID STATE SWITCH
15-10	STOPPER
15-11	PWB ASSY
15-12	PLATE SPRING

Table 1-3. 500 Sheet Paper Cassette Unit - Parts List

Number	Name
15-13	PUSH BUTTON SWITCH
15-14	SHAFT
15-15	JOINT
15-16	ROLLER ASSY
15-17	JOINT
15-18	SOLID STATE SWITCH
15-19	HOLDER
15-20	BUSHING
15-21	GEAR

Table 1-4. Duplex Unit -- Parts List

Number	Name
16-01	GEAR
16-02	GEAR
16-03	GEAR
16-04	GEAR
16-05	GUIDE
16-06	GEAR
16-07	COLLAR
16-08	MOTOR
16-09	REAR COVER
16-10	PLATE SPRING
16-11	HOLDER
16-12	BRACKET
16-13	COLLAR

Table 1-4. Duplex Unit -- Parts List

Number	Name
16-14	TORSION SPRING
16-15	PULLEY
16-16	WIRE
16-17	HOLDER
16-18	PWB ASSY
16-19	ACUTUATOR
16-20	TORSION SPRING
16-21	COVER
16-22	COVER
16-23	HARNESS ASSY
16-24	SOLID STATE SWITCH
16-25	STOPPER
16-26	SHOULDER SCREW
16-27	SPRING
16-28	GEAR
16-29	ROLL
16-30	BUSHING
16-31	ROLLER
16-32	PRESSURE SPRING
16-34	PAWL

## 7.5 Circuit Diagram

---

The following pages show circuit diagram of the controller.

- C314MAIN 1/7
- C314MAIN 2/7
- C314MAIN 3/7
- C314MAIN 4/7
- C314MAIN 5/7
- C314MAIN 6/7
- C314MAIN 7/7

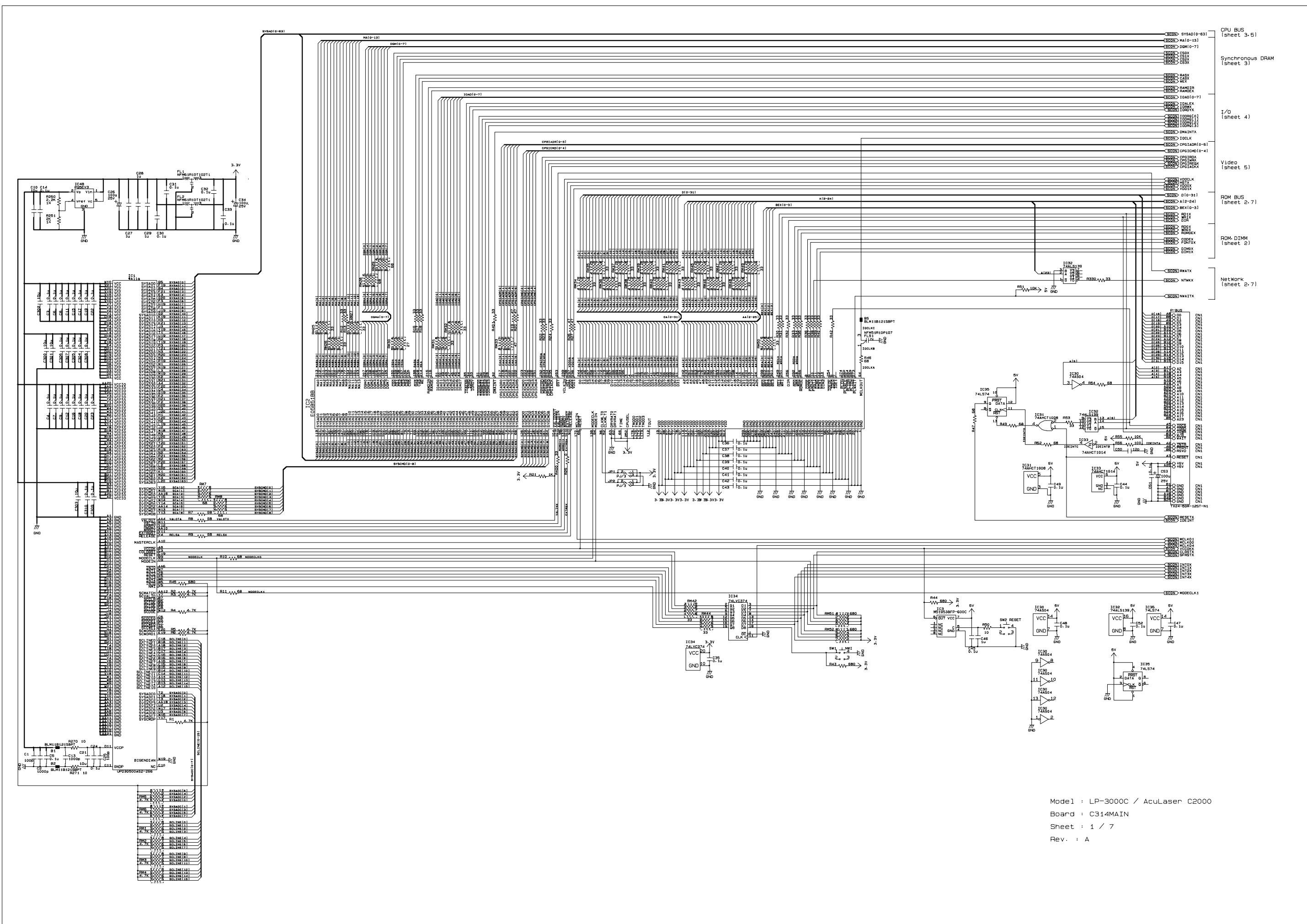

Model : LP-3000C / AcuLaser C2000  
 Board : C314MAIN  
 Sheet : 1 / 7  
 Rev. : A

1

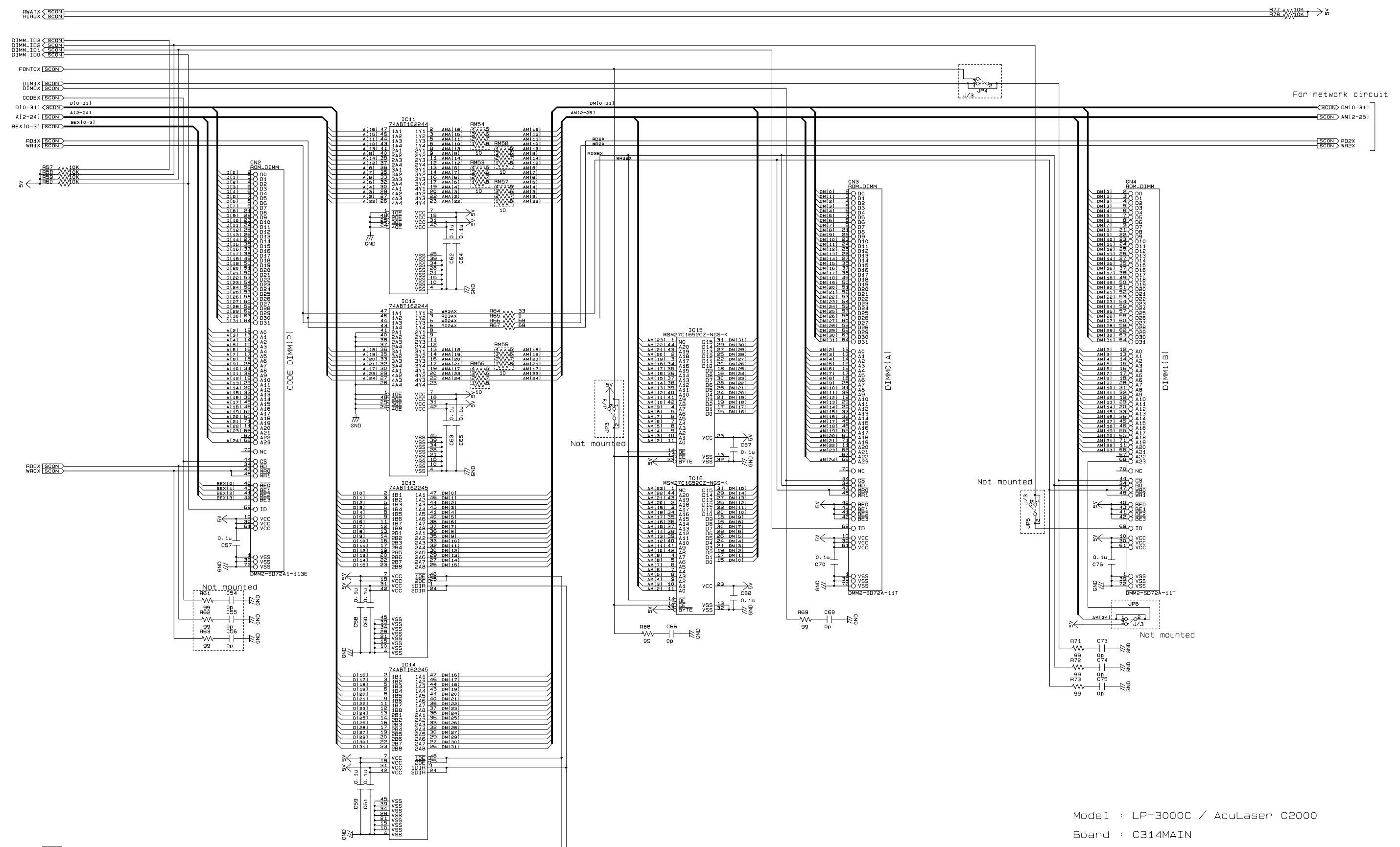

2

3

4

5

6

7

8

1

2

3

4

5

6

7

8

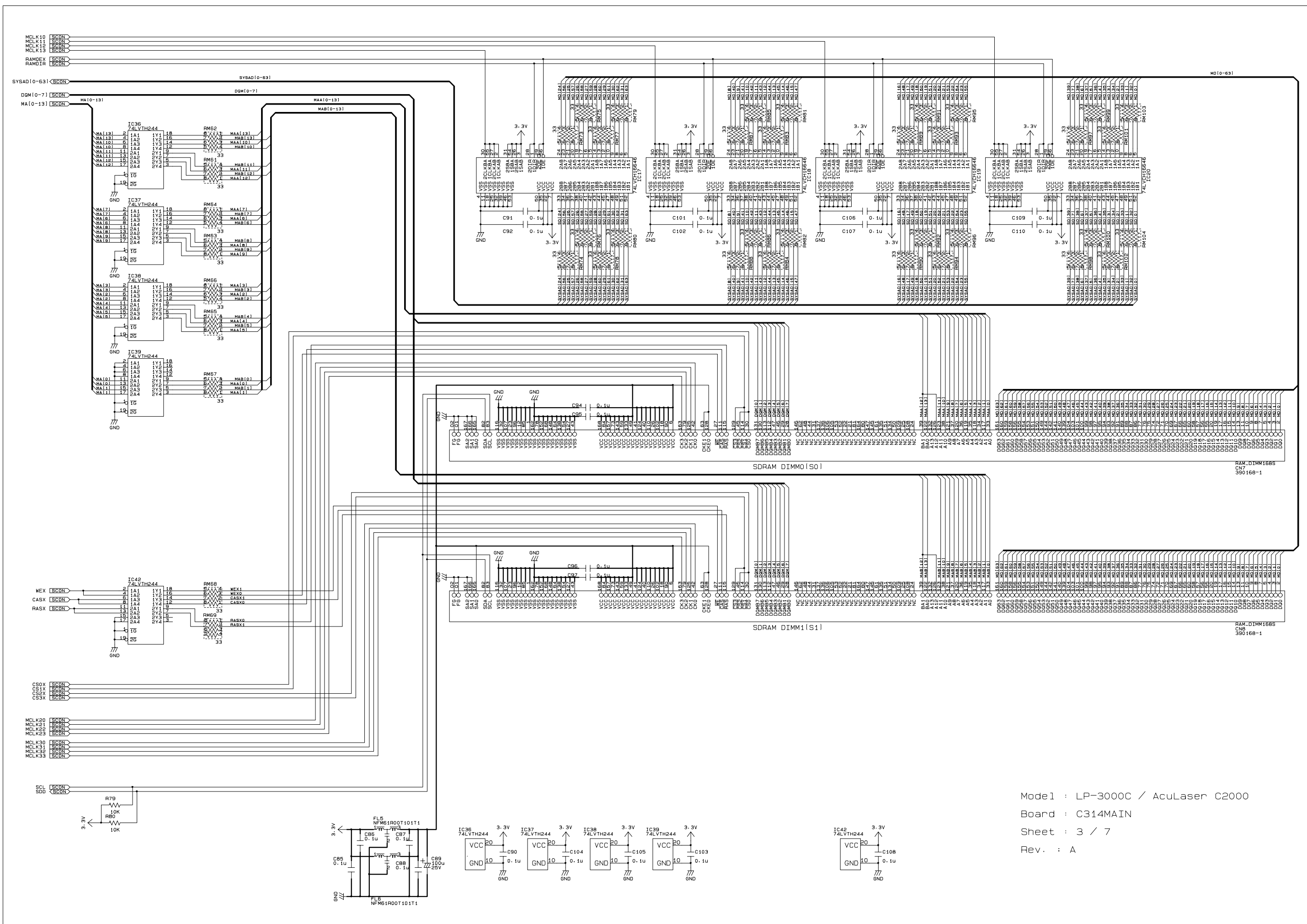

Model : LP-300C / AcuLaser C2000  
 Board : C314MAIN  
 Sheet : 3 / 7  
 Rev. : A



1

2

3

4

5

6

7

8

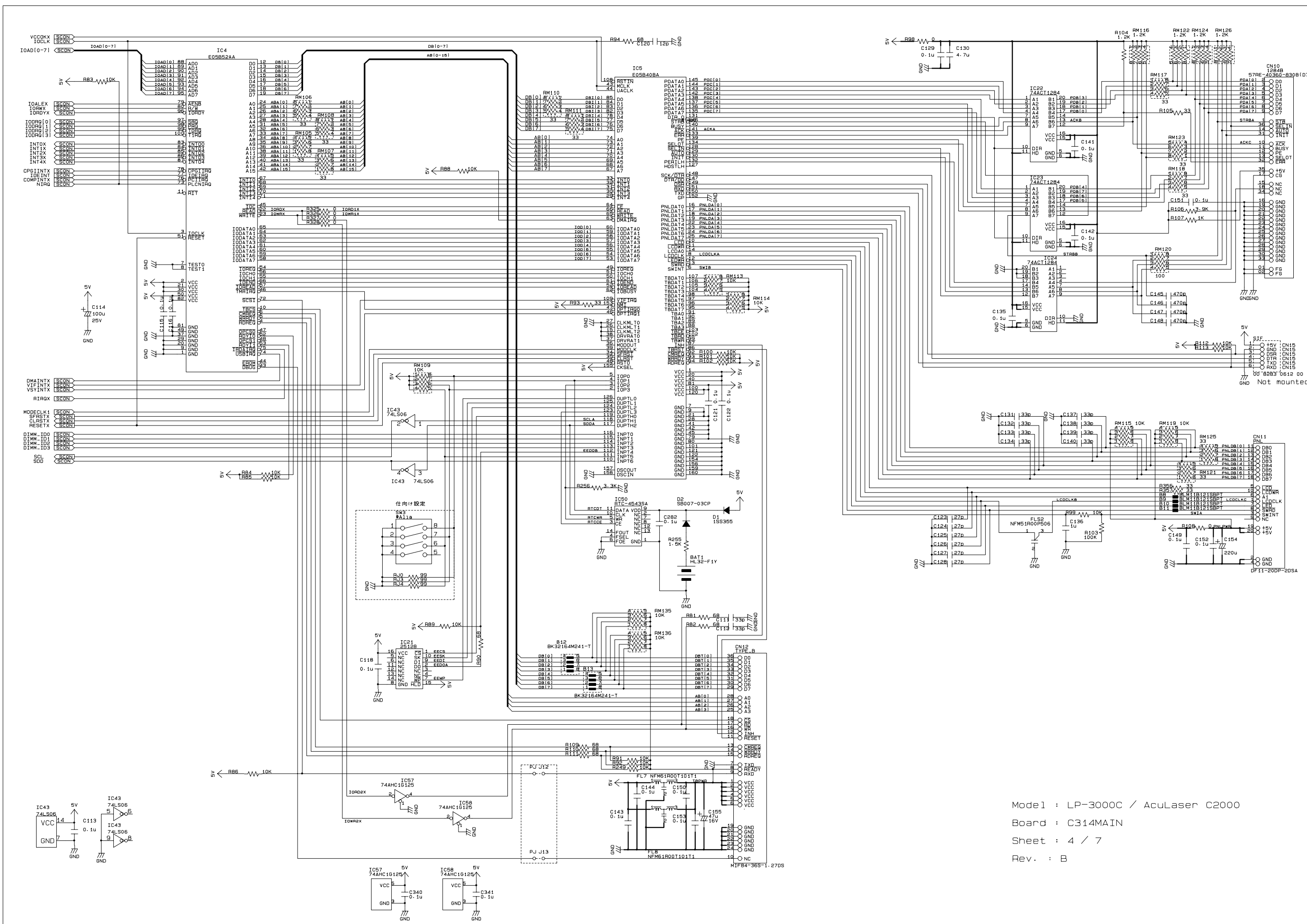

Mode1 : LP-3000C / AcuLaser C2000  
 Board : C314MAIN  
 Sheet : 4 / 7  
 Rev. : B

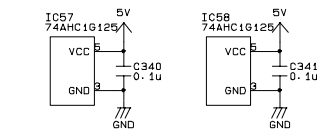
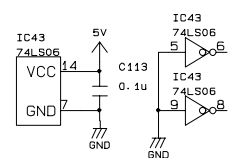

NTP84-365-1.27DS



1

2

3

4

5

6

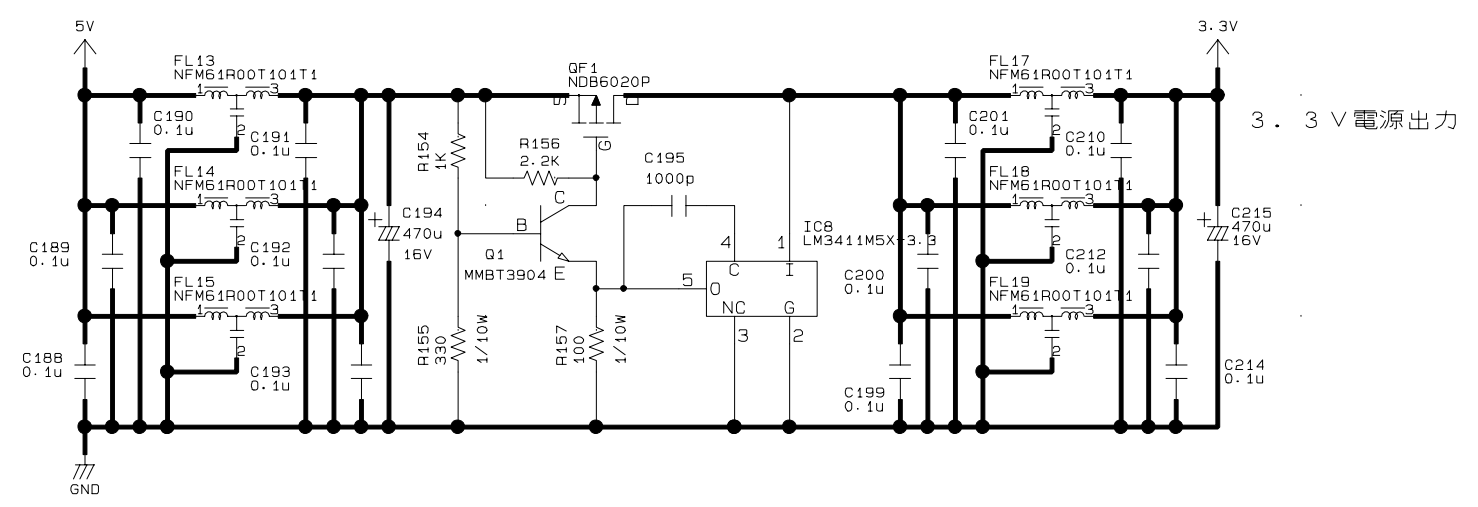
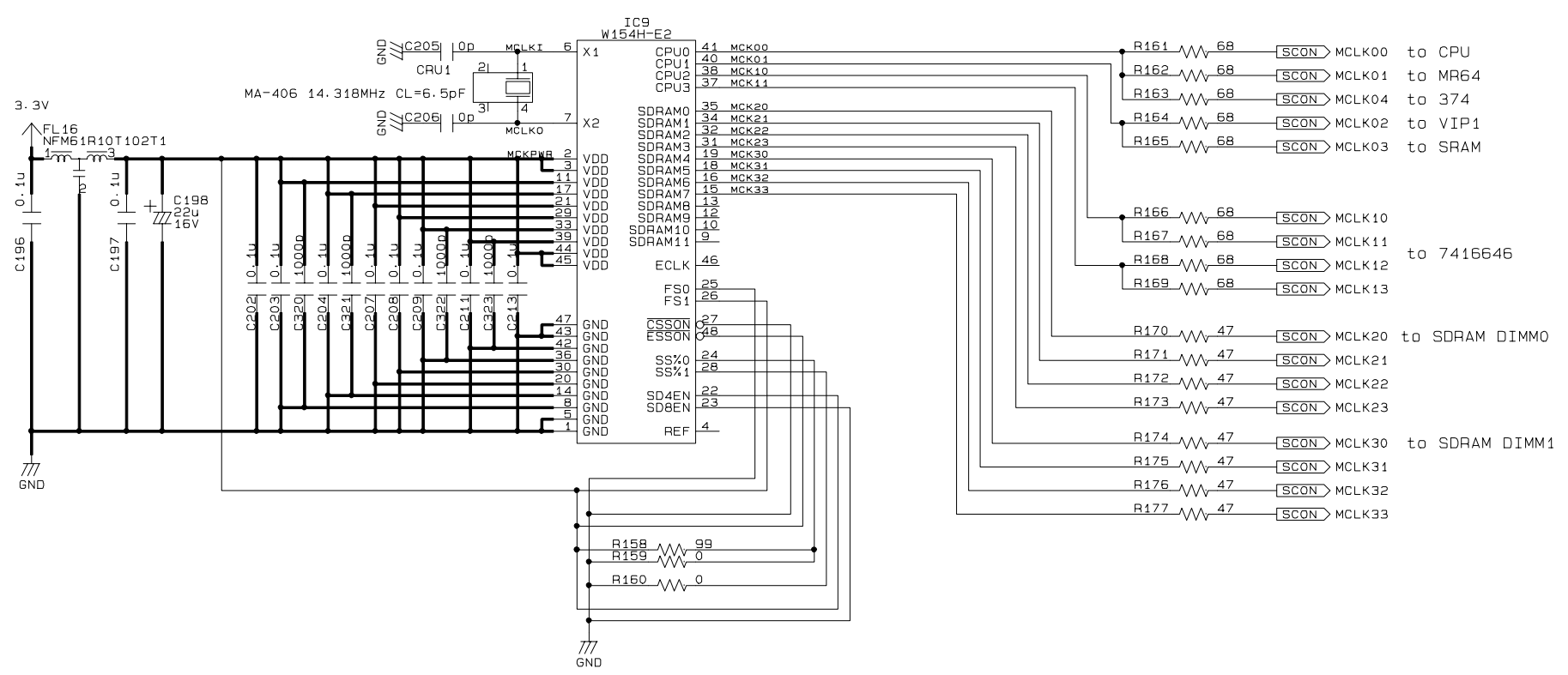

Mode1 : LP-3000C / AcuLaser C2000  
 Board : C314MAIN  
 Sheet : 6 / 7  
 Rev. : A

1

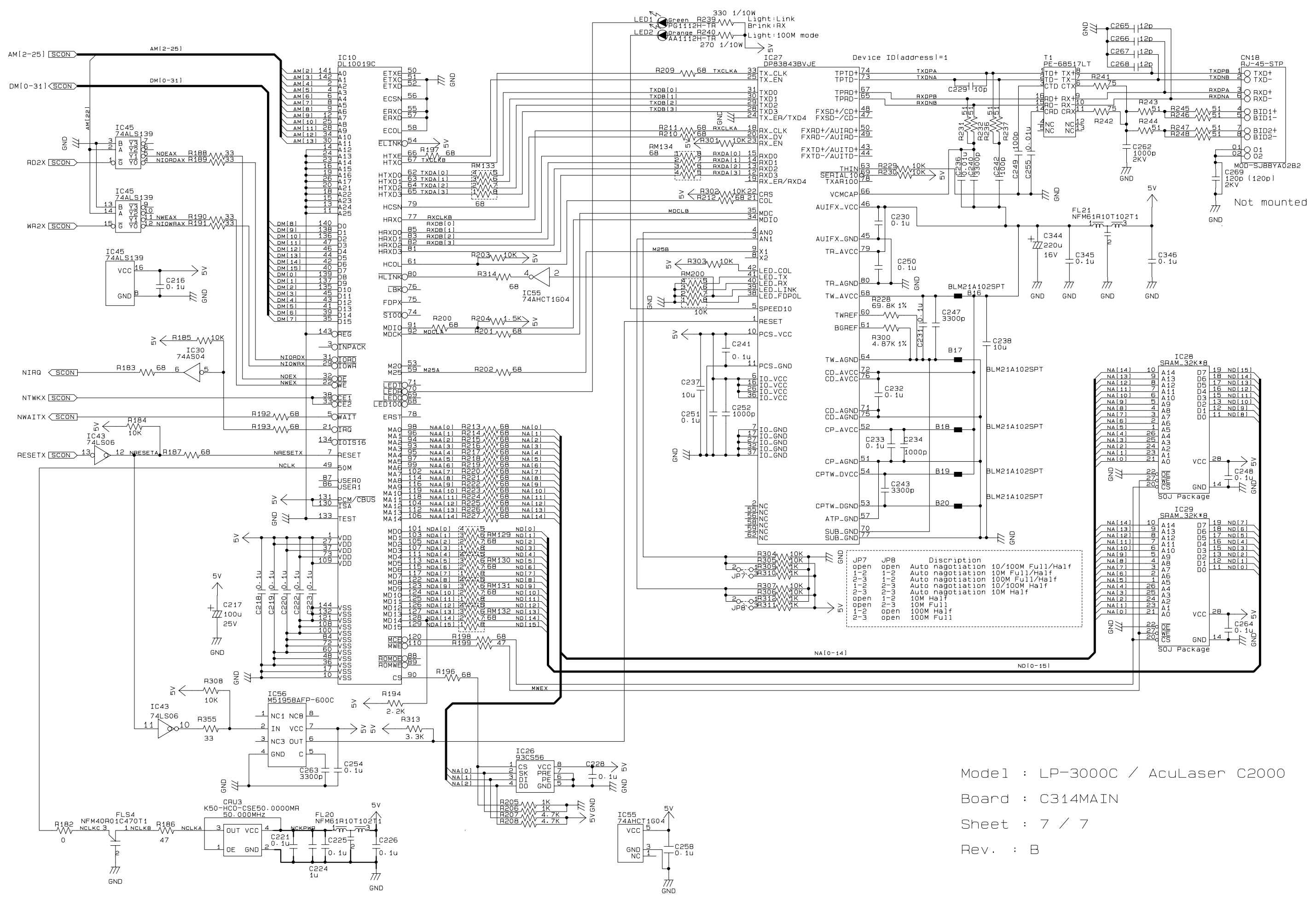

2

3

4

5

6

Mode1 : LP-3000C / AcuLaser C2000  
 Board : C314MAIN  
 Sheet : 7 / 7  
 Rev. : B